

Katarzyna Danys-Lasek

Dongola 2009 : Pottery from Building I (Kom A)

Polish Archaeology in the Mediterranean 21, 315-329

2012

Artykuł został opracowany do udostępnienia w internecie przez Muzeum Historii Polski w ramach prac podejmowanych na rzecz zapewnienia otwartego, powszechnego i trwałego dostępu do polskiego dorobku naukowego i kulturalnego. Artykuł jest umieszczony w kolekcji cyfrowej bazhum.muzhp.pl, gromadzącej zawartość polskich czasopism humanistycznych i społecznych.

Tekst jest udostępniony do wykorzystania w ramach dozwolonego użytku.

DONGOLA 2009: POTTERY FROM BUILDING I (KOM A)

Katarzyna Danys-Lasek

PCMA Associate, Warsaw

Abstract: : Excavation in 2009 on the citadel in Dongola concentrated inside unit B.37 of the palatial Building B.I, including a test pit dug under the floor of the unit. The ceramic assemblage from these excavations is representative of Dongolan pottery production of the 6th and 7th centuries, which drew inspiration from Late Roman models. It consisted mainly of bowls, plates and amphorae, the latter including containers brought as packaging of goods imported from Egypt and Gaza.

Keywords: Dongola, ceramics, pottery, amphorae, Egypt

Excavations on the Citadel (Kom A) in Dongola in the 2009 season were concentrated in Building B.I, called the “Palace”. One of the units cleared in the course of the work was B.I.37, a room situated by the southwestern corner of the building, therefore adjoining the citadel walls.

Like the neighboring room B.I.15, which was explored in the previous season, B.I.37 acted as a storeroom, later latrine depository and rubbish dump. The pottery from the fill of this unit finds numerous parallels with the assemblage recorded from B.I.15. They form a closed group representing a single chronological horizon that encompasses the 7th century. The assemblage from B.I.37 contains extremely abundant tableware (dishes and bowls), in many cases reconstructed whole forms, accompanied by sherds of containers, cooking vessels, lids, vases

and bottles (‘pilgrim’ bottles, as well as handmade vessels) and amphorae. The forms and the decoration are typical of 6th and 7th century Dongolan ceramic production modeled on wares from late Roman Egypt (Pluskota 2001: 361–362, Fig. 6; Phillips 2003: 410).

A test trench was dug below the floor of unit B.I.37 (1.70–1.90 m by 0.80 m to about 1.20 m at the bottom near bedrock, approximately 1 m deep, see also Godlewski 2012: 298, in this volume). The fill consisted of gray earth with a layer of hardened alluvial soil, linked to the foundation of the citadel wall. The test trench contained an abundance of pottery sherds and a few wooden, stone and clay artifacts. No traces of a pit could be seen on the floor of unit B.I.37, which would indicate that the fill — and the ceramic assemblage found in it — predated the establishment of the room. Amphorae

and tableware (dishes and bowls) from the late 6th century and the turn of the century predominated in the deposit. This material represents the earliest phase

of Dongolan pottery production, which drew on a post-Meroitic tradition for inspiration and ready models (Pluskota 1990: 317).

UNIT B.I.37: FILL ABOVE THE FLOOR

The assemblage comprised 72 vessels, of which 35 represented types 5A and 5B, e.g. ADd.09.229 and ADd.09.228 [Fig. 1]. Most of these are Red Ware products with the exception of two sherds (ADd.09.208, ADd.09.432) covered with white slip. The vessels were not decorated in any way.

The second group (in terms of number) was formed by 12 dishes of types 2A, 2B and 2C, e.g. ADd.09.158, ADd.09.215, ADd.09.187 [see Fig. 1]. Most were red-slipped with a few only covered with white slip. One dish (ADd.09.215) featured two grooves on the bottom [see Fig. 1].

The third group was formed of four dishes, both red-slipped (ADd.09.180, ADd.09.180) and white slipped (ADd.09.212, ADd.09.368), characterized by a groove under the rim on the inside [see Fig. 1].

Dishes of type 1 (e.g. ADd.09.143, ADd.09.437) were all red-slipped, decorated with a painted yellow undulating band (ADd.09.143) or continuous white lines with intersecting arcades on the inner ledge of the rim and a radiate rosette on the floor (ADd.09.437) [see Fig. 1].

Dishes of type 7 (ADd.09.221, ADd.09.218) occurred as White Ware products only; the first of the two specimens additionally featured five grooves running around under the rim and a broad red painted band with two black stripes [see Fig. 1].

More than a half of the 41 recorded bowls, that is, 28 examples were classified as type 5. These bowls were red-slipped with the exception of ADd.9.219, which had a white slip. Painted decoration on the inside of the vessel occurred on nine examples [Fig. 2]. It comprised a white band with a center black or orange stripe, either single (ADd.09.222) or double (ADd.09.302), on a red- or cream-slipped (ADd.09.207) or gray background (ADd.09.159). The decoration could be reduced to just a black band on the rim (ADd.09.438) or a yellow radiate rosette (ADd.09.169) or white flower (ADd.09.163) on the bottom. Bowl ADd.09.138 featured an elaborate decoration in the form of a broad deep red band on a white-slip ground inside the bowl, the band patterned with regularly spaced black dots outlined in white and dotted with small white dots, and with a black line flanking the band around the bowl [see Fig. 2].

Fragmentary inscriptions were noted on two bowls of type 5 (ADd.09.175, ADd.09.176). These were engraved post-firing. One is most probably the name MIXAHA [see Fig. 2].

Deep bowls of type 1 [see Fig. 2] represented Red Ware with the sole exception of ADd.09.227, which had a creamish-yellow slip. Most of them were decorated on the outside with grooves under the rim: either one (ADd.09.227, ADd.09.242), two

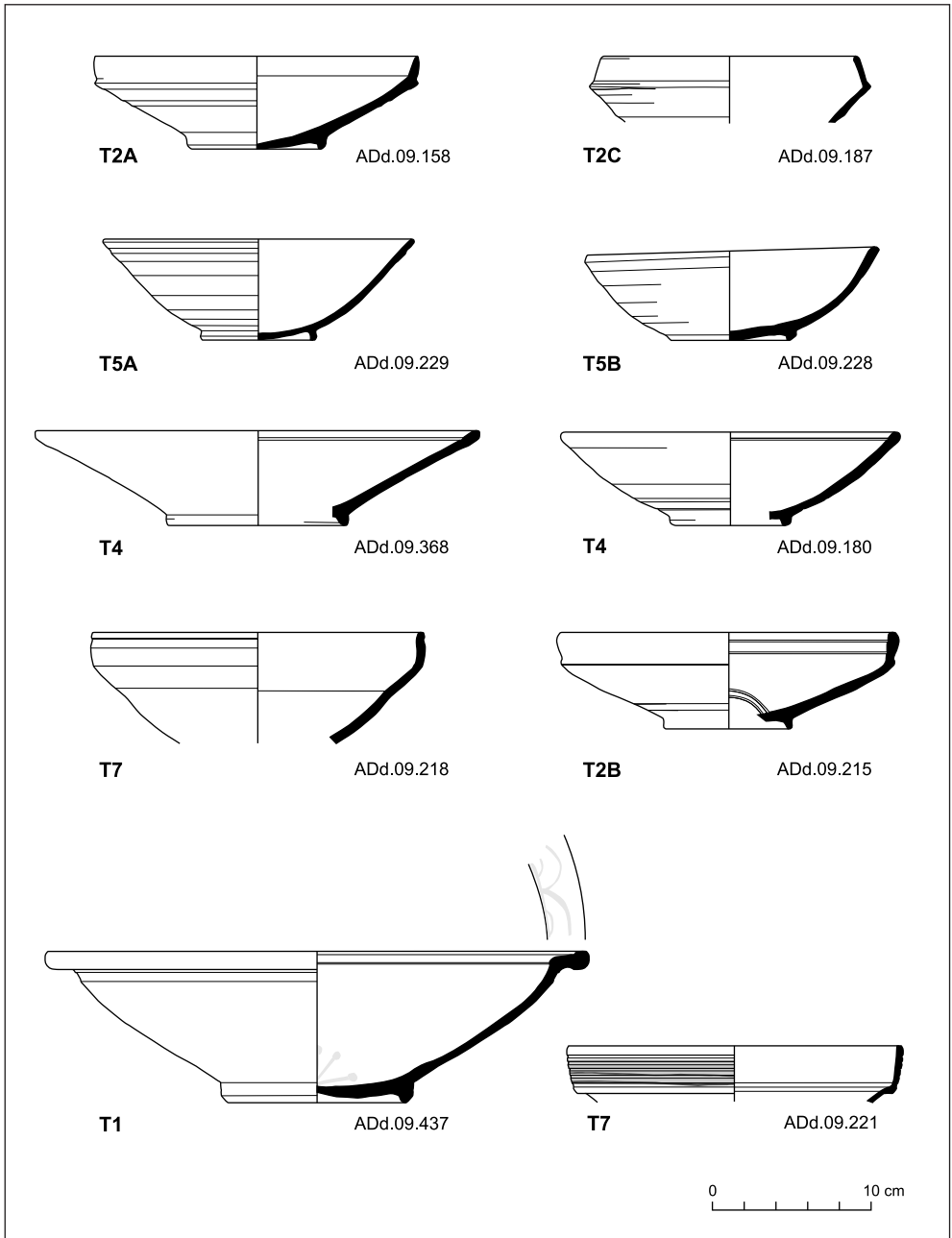

Fig. 1. Dishes from the fill of unit B.I.37
(All drawings by the author)

(ADd.09.140, ADd.09.155) or five (ADd.09.160, ADd.09.443), stamps in the form of a cross (ADd.09.155) and diamond (ADd.09.183) and/or white painted motifs, which included a star (ADd.09.140) and oblique crossing lines (ADd.09.242). A dove is depicted on bowl ADd.09.227, accompanied on the left by a vertical band of hatching [see *Fig. 2*].

Three bowls of type 3 had a natural pink wash, which was effected naturally by the firing process, instead of the regular slip. Vessel ADd.09.209 with black polished surface and black clay in the break is a typical product of the potteries working in the Kingdom of Alwa to the south. Analogous bowls are known from Soba East, where they were found in early

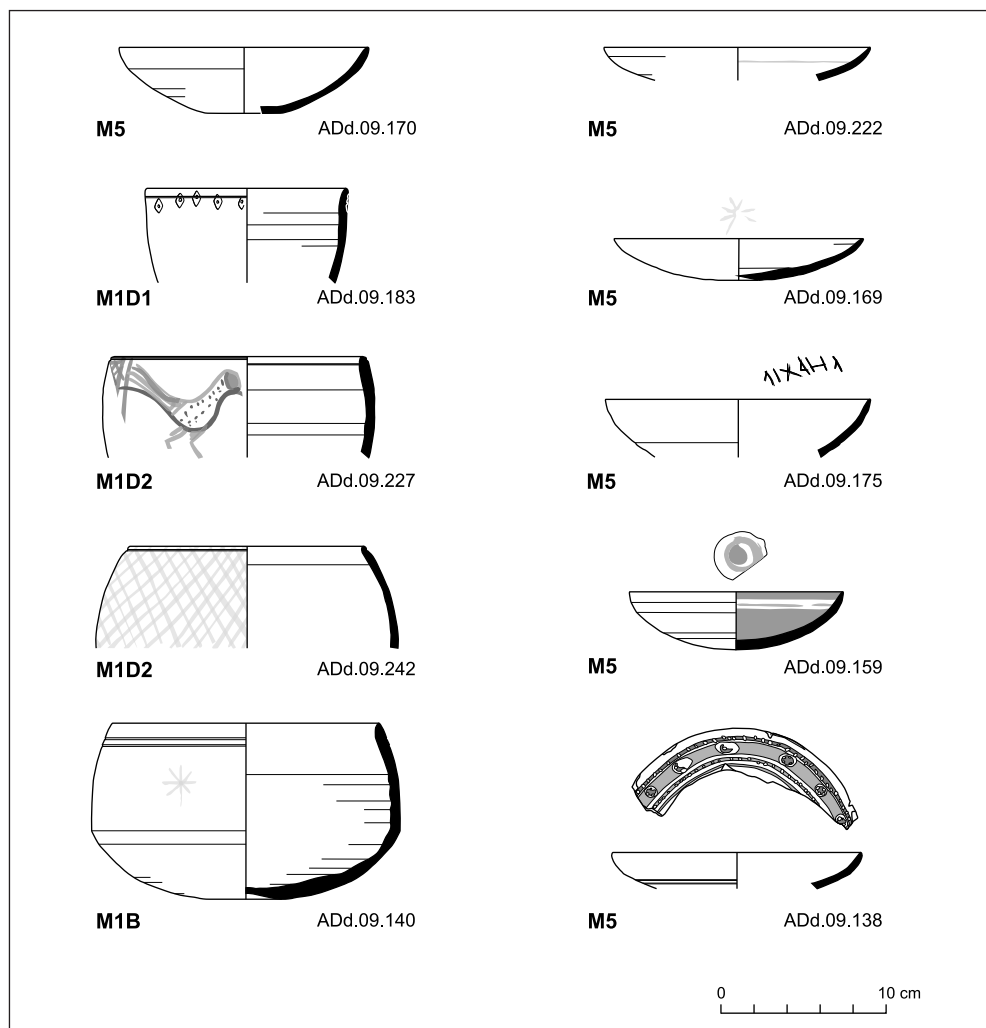

Fig. 2. Bowls from the fill of unit B.I.37

contexts (Welsby, Daniels 1991: 193, Fig. 110.124).

Other tableware from the fill of unit B.I.37 consisted of four vases, a jar, a small jug and a bottle. Vases of type 1 (ADd.09.141, ADd.09.142) with slightly flaring walls, carinated body and ring base were covered with a polished, orange or red slip. Those of type 2 (ADd.09.371, ADd.09.372) with bulging shoulders were yellow-slipped, decorated with red bands, concentric circles, zigzags and spots. An engraved monogram [Fig. 3] is analogous to marks frequently encountered on amphorae from Dongola (Pluskota 2005: Fig. 1). Jar ADd.09.370 [see Fig. 3] had a rim with modeled spout and one handle; the gray-brown slipped surface bore traces of burning. Parallels are known from Elephantine, from contexts dated from the 1st through 5th century (Gempeler 1992: 138–139, Fig. 78, 16–20).

The small jug ADd.09.235 [see Fig. 3] with squat bulging body covered with yellow-white paint finds parallels in Lower Nubia. It was classified by W.Y. Adams as jug type I8 produced in Egypt (Adams 1986: 103, Fig. 53 I8), but the example from Dongola appears to have been produced in a local pottery workshop.

The fill of unit B.I.37 also produced a fragment of rim from a small vessel ADd.09.151 with red slip, described as an inkpot or small bottle for unguents. This form was classified by W.Y. Adams as type N8 (Adams 1986: 103, Fig. 59 N8). Small bottles of this kind are known also from 6th and 7th century Egypt, e.g. from Elephantine (type T723) and Marea (Gempeler 1992: 236, Fig. 77, 16–19; Majcherek 2008: 112, Fig. 39.27).

The set of pilgrim bottles from the fill of unit B.I.37 comprised six examples either red- or dark gray-slipped, some

with decoration on the body in the form of a yellow painted band with arcades (ADd.09.285) and two engraved crossing lines (ADd.09.288) [see Fig. 3]. In one case there was an inscription rendered with white paint (ADd.09.286), too poorly preserved to be legible. One bottle (ADd.09.284) constituted a unique combination of elements typical of pilgrim bottles (rim, neck and handles) and a traditionally formed ovoid body [see Fig. 3]. Handmade bottles (ADd.09.241, ADd.09.239, ADd.09.240), commonly referred to as ‘beer jars’, has strongly flaring rims and narrow necks. The upper parts were covered with red slip, additionally decorated with painted orange bands dotted with black points. Mat impressions were observed on the body of bottle ADd.09.240 without painted decoration [see Fig. 3]. Vessels of this type draw on a post-Meroitic ceramic tradition (Phillips 2003: 403). A large bulbous wheel-made bottle (ADd.09.234) constituted a special find. It was well made and bore an engraved image on the shoulder of a dove holding in its beak an object (branch? incense burner?) [see Fig. 3].

Storage containers formed a numerous group. These were large vessels (e.g. ADd.09.298), covered with an orange-red slip on the outside, white inside with a yellow painted band under the rim [Fig. 4]. Large handmade storage jars (e.g. ADd.09.304, ADd.09.305) were decorated with painted red, white and black motifs (bands, zigzags, circles, spots) on a white ground [see Fig. 4].

Cooking pots, all handmade and poorly preserved, presented heavily sooted bodies. Some bore mat impressions on the surface. A broad bowl (ADd.09.450) with black surface, furnished with a semicircular

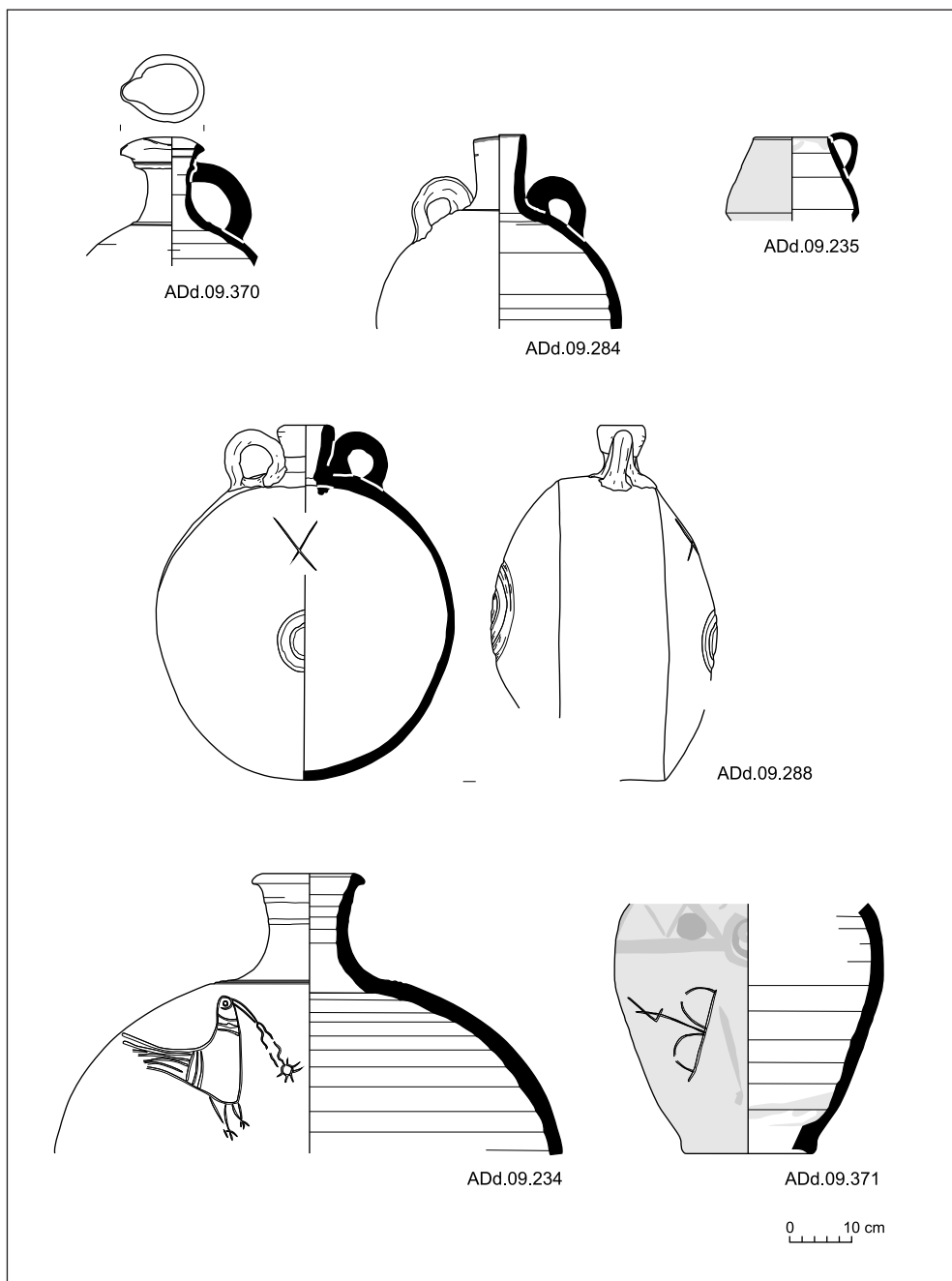

Fig. 3. Jar, small jug, bottle and vase from the fill of unit B.I.37

handle and decorated with oblique engraved notches on the rim, may have been used as a *doka*. Analogous deep bowls are known from Lower Nubia (Adams 1986: 104, Fig. 69) and Banganarti (Phillips 2003: 410).

Lids complement the repertoire of cooking pots (e.g. ADd.09.238, ADd.09.442).

There were 17 amphorae in this set, 14 representing local Dongolan production (types B and C), known from the earliest

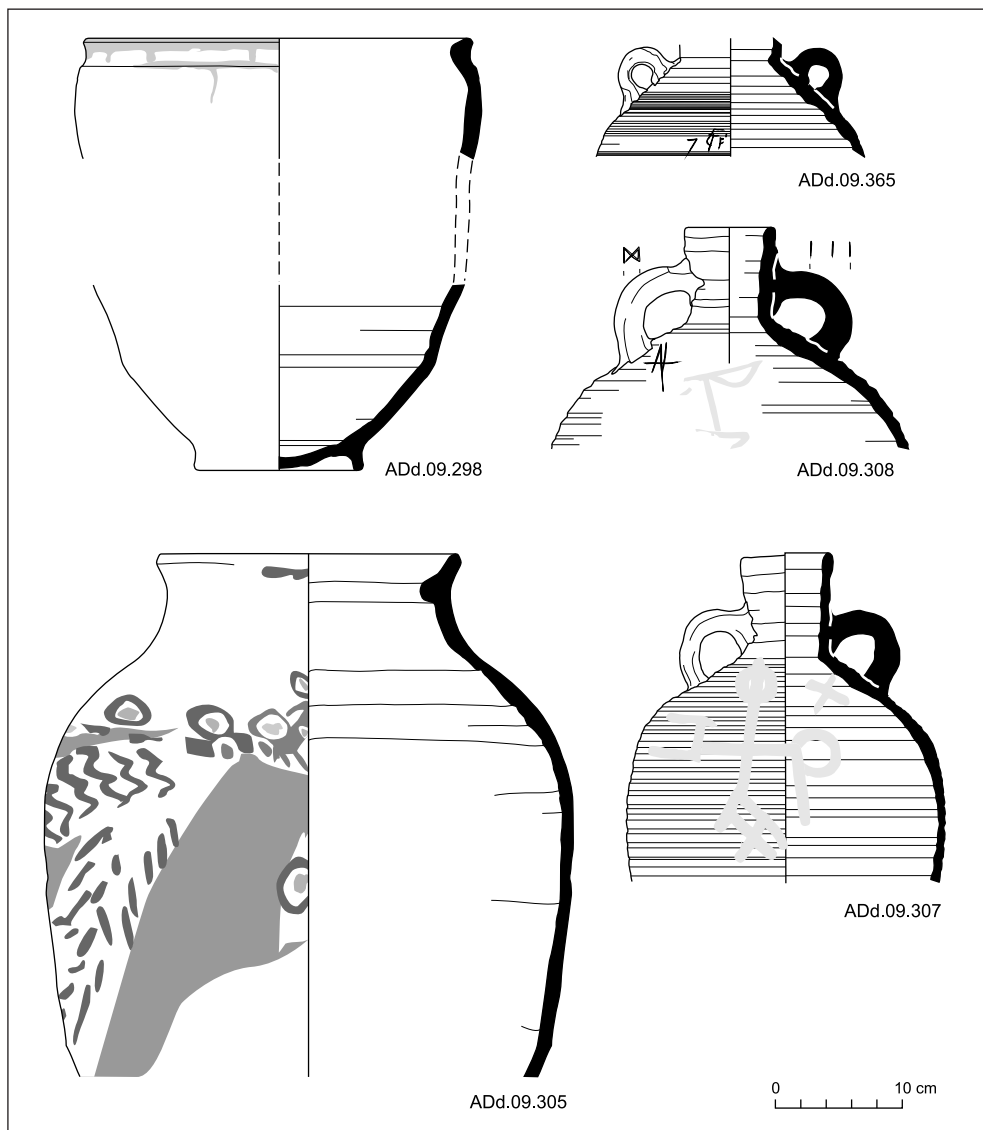

Fig. 4. Storage containers and amphorae from the fill of unit B.I.37

6th and 7th century layers of the pottery workshops on kom R (Pluskota 2005: 229–230, Fig. 8). Yellow- or white-painted monograms were noted on the shoulders of a few vessels, e.g. ADd.09.307, ADd.09.308, ADd.09.313 [see Fig. 4], while the handles of ADd.09.308 bore

an engraved potmark(?). The other three amphorae represented the brown bag-shaped type of vessels which were made in Egypt, in the Mareotis region, e.g. ADd.09.365 [see Fig. 4]; this type of amphora was also discovered in adjoining unit B.I.15 (Godlewski 2002: 208, Fig. 5).

DEPOSIT FROM UNDER THE FLOOR OF UNIT B.I.37

In the assemblage predating the floor in B.I.37 dishes were represented mainly by forms of type 3 (e.g. ADd.09.350, ADd.09.384, ADd.09.404). These were

plain red-slipped vessels, in one case (ADd.09.350) bearing an engraved potmark on the inside [Fig. 5]. The form derives from late Roman models, such as

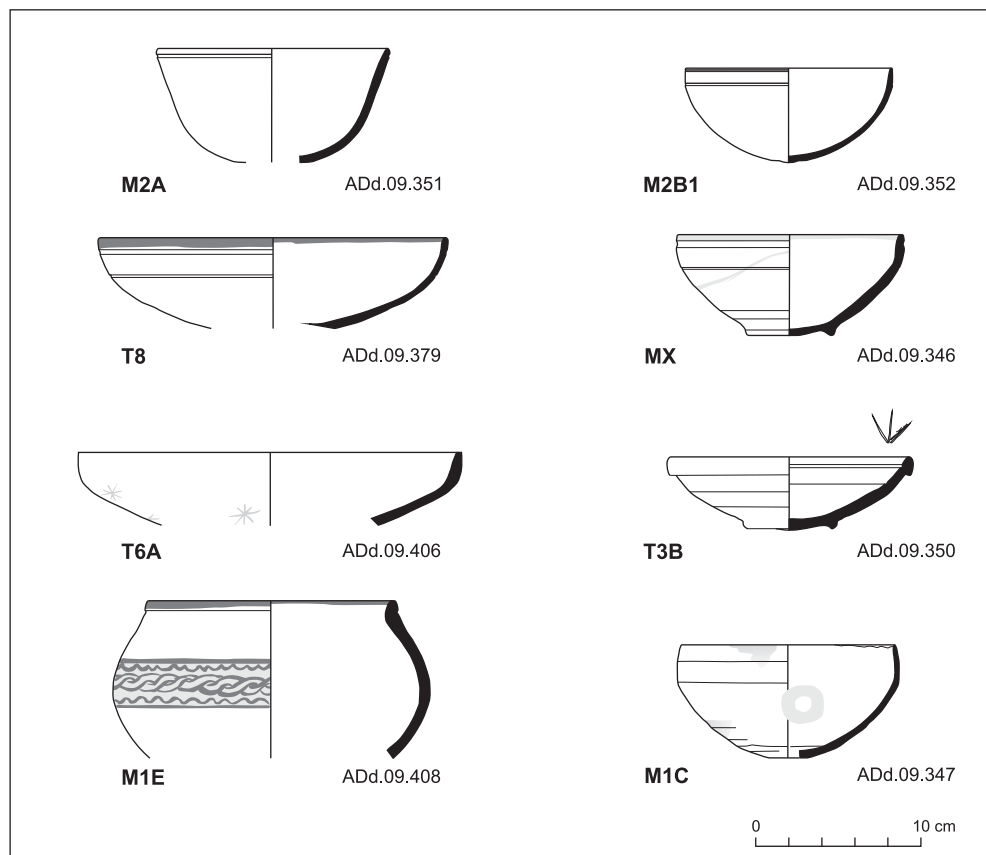

Fig. 5. Dishes and bowls from the under-floor deposit in unit B.I.37

Hayes form 104 (Hayes 1972: 161-166, Fig. 30), borrowed from Egypt to be produced in the earliest phases of Dongolan ceramic production (Pluskota 2001: 362, Fig. 8).

Two other dishes represent type 8 (ADd.09.379, ADd.09.380). Both were red-slipped and the former also featured a black painted band around the edge and two grooves under it [see Fig. 5].

Dish ADd.09.406 (type 6A), a Red Ware product, was exceptional; it was decorated with white-painted stars on the lower part above the base [see Fig. 5].

Bowls were slightly more numerous than dishes. All were deep hemispherical forms, both closed (type 1) and open (type 2). Bowls of type 1 were covered with a plain red unpolished slip, e.g. ADd.09.347 [see Fig. 5], the one exception being ADd.09.409, which was decorated with a groove under the rim, and ADd.09.408 with polished surface and painted orange-black band under the rim and broad orange band between arcaded bands with a guilloche in the center on the body [see Fig. 5]. Those of type 2 [see Fig. 5] represented Red Ware, decorated with grooves in the upper part: one (ADd.09.351), two (ADd.09.352) or five (ADd.09.381). Vessels of this type derive from a post-Meroitic ceramic tradition represented among others by finds from the tombs in Gebel el-Ghaddar (Żurawski 1995: Pl. 14). Red bowls ADd.09.346 and ADd.09.349 with black bands on the rim are a unique product [see Fig. 5].

Tableware included also a few very fragmented thin-walled cups ADd.09.376 and ADd.09.382, showing painted brown and black motifs on a light-coloured slip: a horizontal line with a presumed arm of a cross and part of a rectangular metope. Cups of this kind are typical of the earliest

phase in Dongolan ceramic production in the middle of the 6th century (Pluskota 1990: Fig. 8; Pluskota 1991: Fig. 5ff.).

Handmade bottles ('beer jars') were quite common in the deposit. The necks were covered with red polished slip, in some examples bordered at the bottom with a notched cordon (ADd.09.386, ADd.09.388); the bodies often presented impressed matting and an engraved multiple zigzag pattern [Fig. 6]. The production tradition in the case of these bottles derives from post-Meroitic times (Phillips 2003: 403). The one wheel-made bottle (ADd.09.411) is red-slipped, polished on the surface, featuring a groove under the rim and at the base of the neck [see Fig. 6]. Analogous vessels from Ed-Diffar were described as "Transitional/very Early Dongola" (Phillips 2003: Pl. 33g).

Vases represented two types. The first one had flaring walls (ADd.09.353) covered with an orange-red polished slip and black motifs on a yellow ground [see Fig. 6] characteristic of early Dongolan products (Pluskota 1991: Fig. 14). The other type was a bulbous form (ADd.09.414) with smooth yellow slip and brown painted decoration [see Fig. 6]. Analogous vessels were discovered in the fill of the pottery kilns on kom R in Dongola (Pluskota 2001: 261, Fig. 6).

Cooking vessels represented a standard repertoire of forms and decoration. Meriting attention is a finely made vessel, ADd.09.390, the neck red-slipped and polished with a series of round knobs at the base [see Fig. 6]. A fragment of a *doka* (ADd.09.430) bore engraved crossing lines at the edge, perforations below this and mat impressions on the body. Last but not least in this group are two small

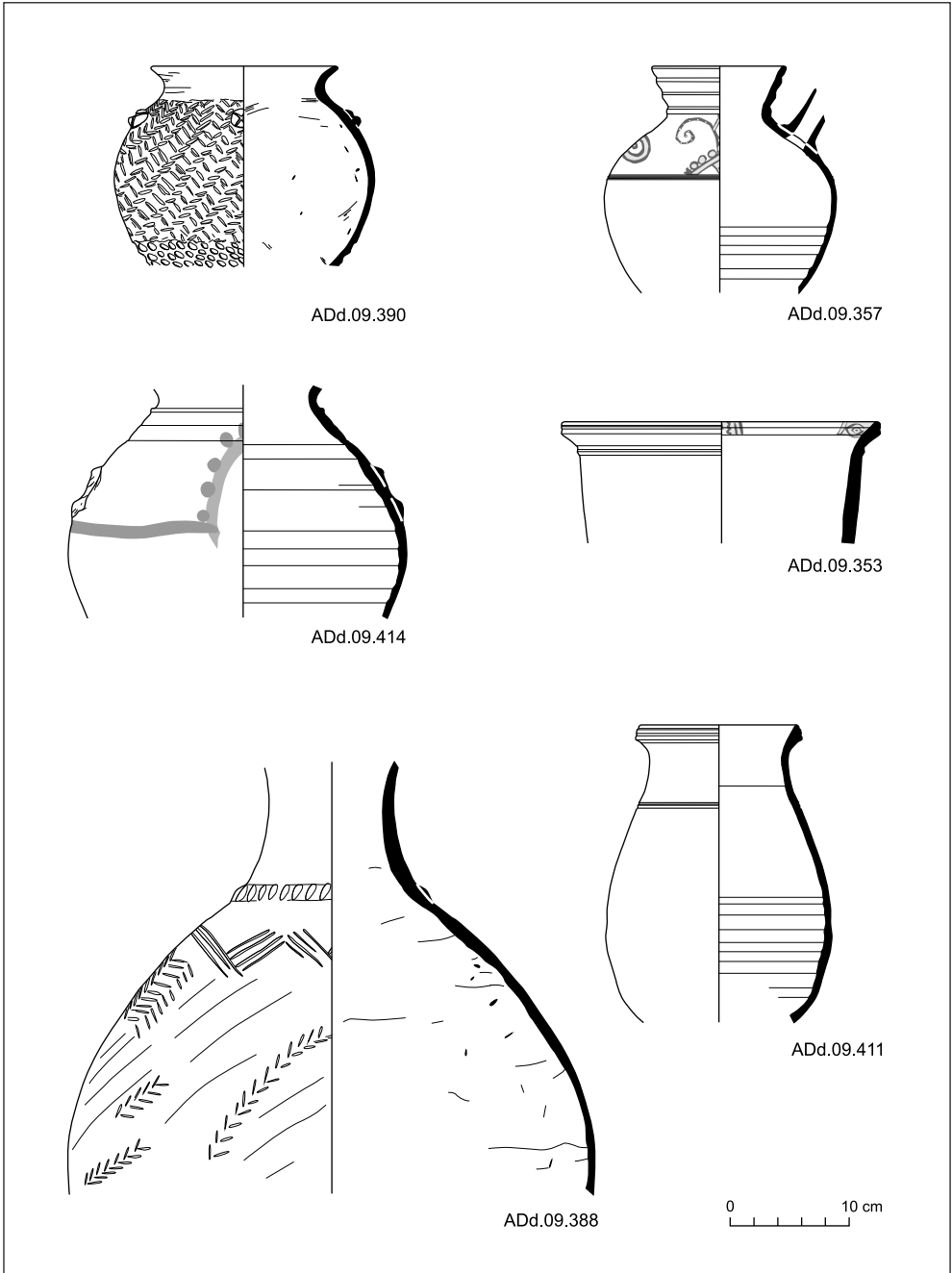

Fig. 6. Vase, bottle, kitchen ware vessel and abriq from the under-floor deposit in unit B.I.37

red-slipped pots used as a kettle (*abriq*?): a plain smaller one (ADd.09.344) and a larger one (ADd.09.357) painted with black motifs on yellow ground [see *Fig. 6*].

One of the two storage containers from the under-floor deposit, ADd.09.415, was red-slipped on the outside, sported a yellow-white slip on the inside, and a thick roll of clay applied below the rim [Fig. 7]. The other vessel, ADd.09.429 [see *Fig. 7*] has a unique shape and decoration in the form of finger impressions on the rim, black-painted motifs (spirals, dotted lines, double festoons with dots between the lines) and rope impressions in the bottom part. Two inscriptions of identical content appeared on the upper part at a certain distance from one another; they can be read as ΠΑΖΑΜΑ (A. Łajtar, personal communication).

The form and decoration are unparalleled among Dongolan products and may have been borrowed from Egypt; indeed, the vessel may be an import. Similar vessels are known from, among others, 5th and 6th century assemblages from Tod (Lecuyot, Pierrat-Bonnefois 2004: 155, Pl. 3.33), mid 6th and mid 7th century layers in Tell Arbid where figural, plant and animal representations are known to appear beside geometric motifs (Górecki 1990: 35, 37, Figs 13–14) and Elephantine although there spiral decoration is found on vessels differing from ADd.09.429, dated from the 5th through the 7th centuries (Gempeler 1992: 173–174, Figs 105,2, 107,3).

Amphorae definitely dominated the under-floor deposit from B.I.37. Individual vessels were relatively well preserved and

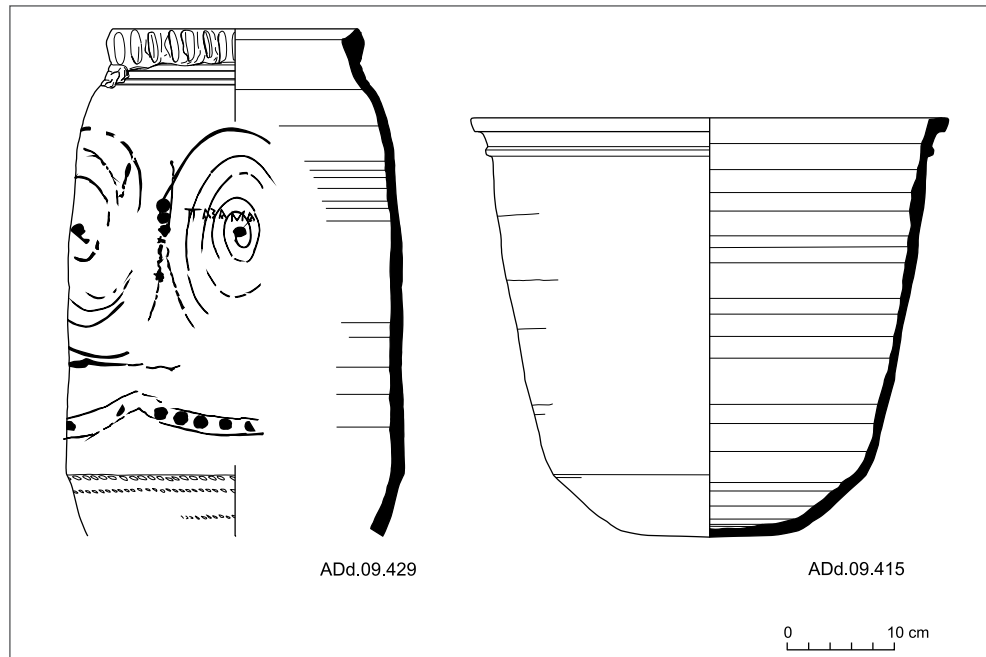

Fig. 7. Storage container from the under-floor deposit in unit B.I.37

it is estimated that there could have been as many as 50 containers with only 10% of these representing locally made wares. It is the biggest concentration of imported vessels discovered so far in a single context in Dongola. The best preserved in this assemblage was a set of 17 south Egyptian amphorae, among others, ADd.09.354,

ADd.09.355, ADd.09.356 [see *Fig. 8*], referred to as type K715 on Elephantine, said to have been in use there from the 6th to the 7th/8th century AD (Gempeler 1992: 191, Fig.122,1–5). Amphora ADd.09.398 had a broad white band painted on the shoulder and all of the vessels from the under-floor deposit were thickly resinated on the inside.

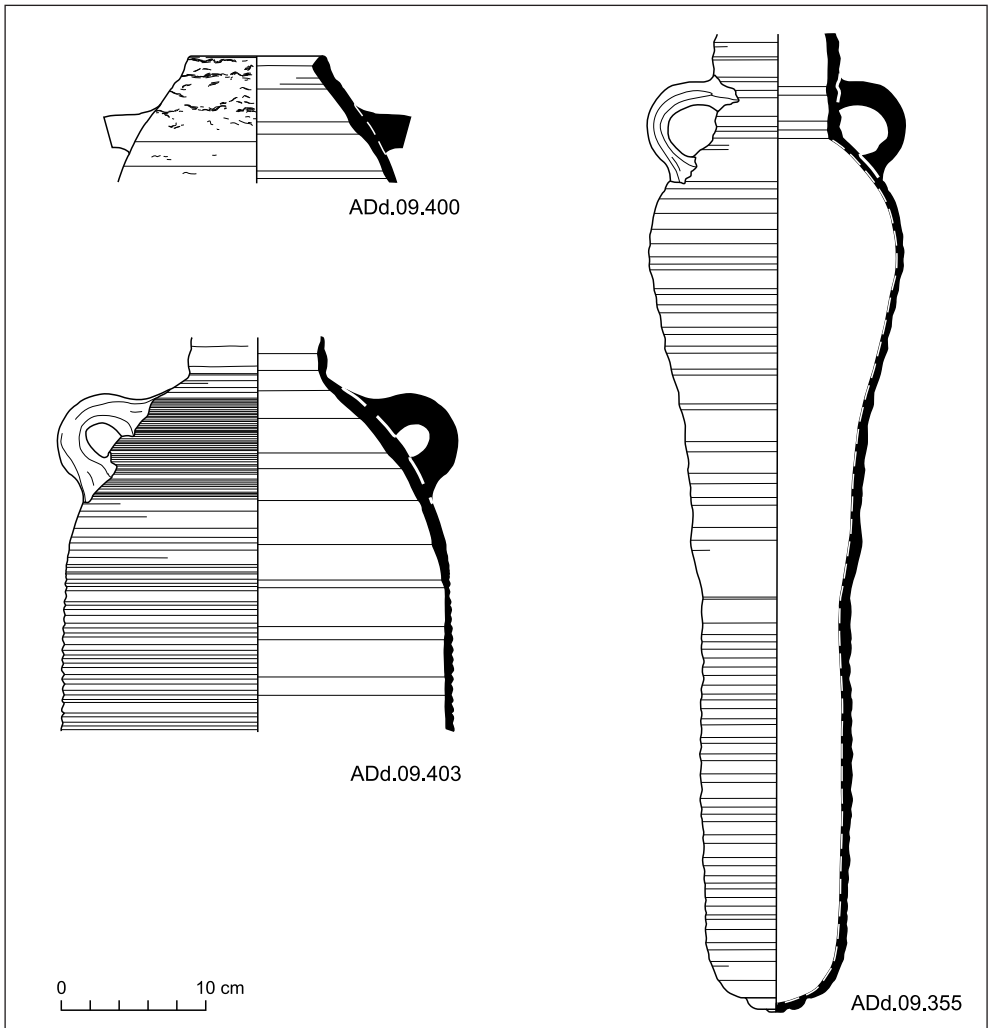

Fig. 8. Amphorae from the under-floor deposit in unit B.I.37

The next most numerous group in the deposit comprised 20 fragmentary amphorae of the LR 7 type, which was a staple product of Middle Egyptian pottery workshops. The shoulders of these vessels differed from gently rounded (ADd.09.394) to sharply carinated with strong ribbing on the surface (ADd.09.392) and an applied wavy band (ADd.09.391). All the sherds had resinated black surfaces on the inside. Brown LR 7 amphorae were extremely common and are a common find on archaeological sites in Egypt and beyond, e.g. Deir el-Naqlun (Godlewski 1990: Figs 20, 21, 24; Górecki 1993: Fig. II.4) and Kellia (Egloff 1977: Pl. 58.5,8).

Other imported amphorae represented bag-shaped LR 5/6 vessels from the Mareotis region, e.g. ADd.09.399, ADd.09.401, ADd.09.402, ADd.09.403 [see Fig. 8]. Dongolan examples are yellow-slipped with combed decoration on the upper parts and ribbing below, black-resinated inside. LR 5/6 amphorae have been discovered in Egypt, at Kellia for example (Egloff 1977: Pl. 6.4; Ballet, Picon 1987: 33–34) and Alexandria (Majcherek 2008: Fig. 7.5), as well as in Lower Nubia (Adams 1986: 574, Fig. 316.21).

There was one example of an imported LR 4 amphora (ADd.09.400) [see Fig. 8]. The surface below the rim was smeared with wet clay and the inside bore evidence of being resinated. Analogous amphorae are known from, among other places, Alexandria: type 4 according to G. Majcherek (1995: 169, Pl. 7.2), and Old Cairo (Gascoigne 2007: 165, Fig. 8).

Amphorae of local manufacture (e.g. ADd.09.451, ADd.09.454) were definitely less numerous compared to sherds of imported containers. All were typical Dongolan products (types B and C) recorded in the 6th and 7th century layers of the pottery kilns discovered on kom R (Pluskota 2005: 229–230, Fig. 8). Some bore painted monograms on the shoulders (e.g. ADd.09.412), analogous to the ones found in the fill of the unit above the floor.

The deposit also contained an incomplete single-nozzle oil lamp (ADd.09.343) of the “candle-holder” type [Fig. 9]. Analogous objects are known from Lower Nubia (Adams 1986: Fig. 278.19), the graves of Gebel el-Ghaddar (Żurawski 1995: Pl. 11) and Dongola (Bagińska 2008: Fig. 1j).

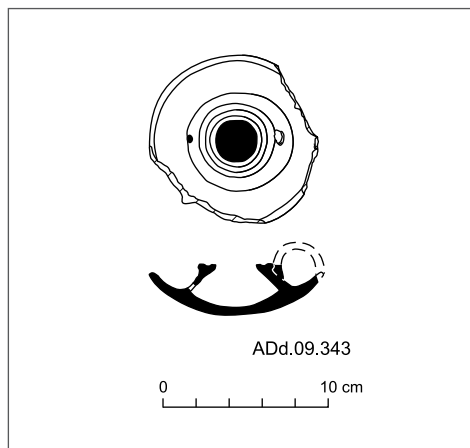

Fig. 9. Oil lamp from the deposit under room B.I.37 in Dongola

REFERENCES

- Adams, W.Y.
1986 *Ceramic Industries of Medieval Nubia* [=Memoirs of the UNESCO Archaeological Survey of Sudanese Nubia 1], Lexington, KY: University Press of Kentucky
- Bagińska, D.
2008 Christian pottery from Old Dongola (Kom H), *PAM* 18 (*Reports 2006*), 361–375
- Ballet, P., Picon, M.
1987 Recherches préliminaires sur les origines de la céramique des Kellia (Égypte). Importations et productions égyptiennes, *CCE* 1, 17–48
- Egloff, M.
1977 *Kellia, la poterie copte. Quatre siècles d'artisanat et d'échanges en Basse-Egypte I–II* [=Recherches suisses d'archéologie copte 3], Geneva: Georg
- Gascoigne, A.L.
2007 Amphorae from Old Cairo. A preliminary note [in:] S. Marchand, A. Marangou (eds), *Amphores d'Égypte. De la basse époque à l'époque arabe I* [=CCE 8/1], Cairo: Institut français d'archéologie orientale, 161–174
- Gempeler, R.D.
1992 *Elephantine X. Die Keramik römischer bis früharabischer Zeit* [=AV 43], Mainz am Rhein: Philipp von Zabern
- Godlewski, W.
1990 Coptic pottery from Deir el Naqlun (Fayum) [in:] W. Godlewski (ed.), *Coptic and Nubian Pottery. International Workshop, Nieborów, August 29–31, 1988*, I [=Occasional Paper of the National Museum in Warsaw 1], Warsaw: National Museum in Warsaw, 49–62
2002 Old Dongola. Kom A, 2001, *PAM* 13 (*Reports 2001*), 203–216
- Górecki, T.
1993 Deir el-Naqlun 1992: The pottery, *PAM* 4 (*Reports 1992*), 53–64
- Hayes, J.W.
1972 *Late Roman Pottery*, London: British School at Rome
- Lecuyot, G., Pierrat-Bonnefois, G.
2004 Corpus de la céramique de Tôd. Fouilles 1980–1983 et 1990, *CCE* 7, 145–210
- Majcherek, G.
1995 Gazan amphorae: Typology reconsidered [in:] H. Meyza, J. Młynarczyk (eds), *Hellenistic and Roman Pottery in the Eastern Mediterranean — Advances in Scientific Studies. Acts of the II Nieborów Pottery Workshop, Nieborów, 18–20 December 1993*, Warsaw: ZAŚ PAN, 163–178
2008 The pottery assemblage from the baths and *sāqiyah* [in:] H. Szymańska, K. Babraj (eds), *Marea I. Byzantine Marea. Excavations in 2000–2003 and 2006* [=Biblioteka Muzeum Archeologicznego w Krakowie 4], Kraków: Muzeum Archeologiczne, 105–127

Phillips, J.

- 2003 An overview of the ceramics [in:] B. Żurawski (ed.), *Survey and Excavations between Old Dongola and Ez-Zuma* [=Nubia 2; Southern Dongola Reach Survey 1], Warsaw: Neriton, 387–437

Pluskota, K.

- 1990 Early Christian pottery from Old Dongola [in:] W. Godlewski (ed.), *Coptic Studies. Acts of the Third International Congress of Coptic Studies, Warsaw, 20–25 August 1984*, Warsaw: Éditions Scientifiques de Pologne, 316–337
- 1991 A pottery production centre from the Early Christian Period [in:] W. Godlewski (ed.), *Coptic and Nubian Pottery. International Workshop, Nieborów, August 29–31, 1988*, II [=Occasional Paper of the National Museum in Warsaw 2], Warsaw: National Museum in Warsaw, 34–56
- 2001 The kiln sites of Old Dongola [in:] S. Jakobielski, P.O. Scholz (eds), *Dongola-Studien, 35 Jahre polnischer Forschungen im Zentrum des makuritischen Reiches* [=Bibliotheca nubica et aethiopica 7], Warsaw: ZAŚ PAN, 357–365
- 2005 Amphorae of Old Dongola. Evolution of local products (exploration of kiln R1 F), *GAMAR* 3, 227–232

Welsby, D.A., Daniels, C.M.

- 1991 *Soba. Archaeological Research at a Medieval Capital on the Blue Nile* [=Memoirs of the British Institute in Eastern Africa 12], London: British Institute in Eastern Africa

Żurawski, B.

- 1995 Pottery in mortuary complex. Transitional/Early Christian period in Nubia [in:] H. Meyza, J. Młynarczyk (eds), *Hellenistic and Roman Pottery in the Eastern Mediterranean — Advances in Scientific Studies. Acts of the II Nieborów Pottery Workshop, Nieborów, 18–20 December 1993*, Warsaw: ZAŚ PAN, 463–494