

**Żelazowski, Jerzy /  
Rekowska-Ruszkowska, Monika /  
Kowarska, Zofia i in.**

---

**Polish Archaeological Research in  
Ptolemais (Libya) in 2007-2009 :  
Preliminary Report**

---

Światowit 8 (49)/Fasc.A, 9-30

---

2009-2010

Artykuł został zdigitalizowany i opracowany do udostępnienia w internecie przez Muzeum Historii Polski w ramach prac podejmowanych na rzecz zapewnienia otwartego, powszechnego i trwałego dostępu do polskiego dorobku naukowego i kulturalnego. Artykuł jest umieszczony w kolekcji cyfrowej [bazhum.muzhp.pl](http://bazhum.muzhp.pl), gromadzącej zawartość polskich czasopism humanistycznych i społecznych.

Tekst jest udostępniony do wykorzystania w ramach dozwolonego użytku.

JERZY ŻELAZOWSKI, MONIKA REKOWSKA-RUSZKOWSKA, ZOFIA KOWARSKA, SZYMON LENARCZYK, KRZYSZTOF CHMIELEWSKI, ELŻBIETA ROSŁONIEC, PIOTR JAWORSKI, KRZYSZTOF MISIEWICZ, KAZIMIERZ LEWARTOWSKI, GEORGE YACCOUB, MIRON BOGACKI, WIESŁAW MAŁKOWSKI, ZBIGNIEW POLAK

**POLISH ARCHAEOLOGICAL RESEARCH IN PTOLEMAIS (LIBYA) IN 2007–2009.  
PRELIMINARY REPORT  
(PLS. 1–33)**

**Excavations**

**(Jerzy Żelazowski, Monika Rekowska-Ruszkowska, Zofia Kowarska, Szymon Lenarczyk)**

From the start in 2001 the excavations of the University of Warsaw's Institute of Archaeology in Ptolemais (Libya) were determined by the discovery of the official part of the House of Leukaktios (also called the Villa with a View) in the first few seasons. The house was drawn round a four-column peristyle with impressive architectural, painted and mosaic decoration (Fig. 1).<sup>1</sup> The chambers around the peristyle were cleared and the intervening baulks removed (Fig. 2). At the same time, work in an area to the north of this part of the building<sup>2</sup> revealed a set of chambers on a lower level of occupation, belonging to another habitational structure later incorporated into a large apsidal hall (Fig. 7). Excavations in this part clearly demarcated the limits of the House of Leukaktios, which is situated on a higher level compared with the architecture lying to the north of it.

Archaeological explorations began in 2006 on the south side of the House of Leukaktios. They uncovered a small complex featuring a kind of paved atrium with an impluvium (Fig. 4).<sup>3</sup> It occupied a higher occupational level, although there is evidence in the form of blocking (Fig. 5) in the south wall of the triclinium (R 1) and transformations in the late phases of use of this part of the insula, indicating simultaneous use of the two levels in different periods. Even so, when the House of Leukaktios was in use, the house with the impluvium, collecting rainwater into a cistern, operated independently with an entrance (R 44) from the western street (Fig. 6). The south walls of Rooms R 48, R 52 and R 56 were proved quickly to mark the limits of this house and the levelling as well, but the exploration of successive rooms continued. Moreover, the excavation method changed starting in 2006, replacing the square grid technique of exploration with room by room excavation and recording that is commonly practiced in the archaeology of ancient towns (Fig. 3).

In 2007, Spring and Autumn seasons were conducted,<sup>4</sup> concentrating overall on geophysical research<sup>5</sup> and

<sup>1</sup> Preliminary reports are published successively in "Światowit" (cf. T. MIKOCCI ET AL., "Światowit" III(XLIV)/A, 2001, 101–120; V(XLVI)/A (2003), 2004, 107–118; VI(XLVII)/A (2004–2005), 2006, 93–107); cf. also T. MIKOCCI ET AL., *Polish Archaeological Research in Ptolemais (Cyrenaica) in years 2001–2007*, "Libya Antiqua" n.s. V, 2010, 99–107 (selected bibliography on p. 107); T. MIKOCCI, *Le campagne di scavo della Missione Archeologica Polacca a Tolemaide (Ptolemais) condotte tra il 2004 e il 2005*, (in:) M. Luni (ed.), *Cirene e la Cirenaica nell'antichità*, Monografie di Archeologia Libica XXX, Roma 2010, 187–195; J. ŻELAZOWSKI, *Le indagini archeologiche polacche a Ptolemais*, (in:) E. Jastrzębowska, M. Niewójt (eds.), *Archeologia a Tolemaide. Giornate di studio in occasione del primo anniversario della morte di Tomasz Mikocki, 27–28 maggio 2008*, Roma 2009, 110–124; M. REKOWSKA-RUSZKOWSKA, J. KANISZEWSKI, *Na zachód od Aleksandrii..., czyli o polskich wykopaliskach w Ptolemais (2001–2009)*, (in:) J. Kościuk (ed.), *Non solum villae. Księga jubileuszowa ofiarowana Prof. Stanisławowi Medekszy*, Wrocław 2010, 265–282.

<sup>2</sup> The assumption to facilitate orientation is that streets in Ptolemais are aligned with the main geographical directions, although in reality they deviate from the magnetic north by some 43 degrees to the west, cf. W. MAŁKOWSKI, K. MISIEWICZ,

*Topographical and Geophysical Prospection*, (in:) T. Mikocki et al., *Polish Archaeological Research...*, 105.

<sup>3</sup> On typology of Cyrenaican houses see: G. BEJOR, *Contributi cirenaici alla storia della casa greca in età romana*, (in:) E. Catani, S.M. Marengo (eds.), *La Cirenaica in età antica, Atti del Convegno Internazionale di Studi (Macerata, 18–20.05.1995)*, Macerata 1998, 35–42; G. SPINOLA, *Note sull'evoluzione planimetrica delle domus della Cirenaica*, (in:) L. Bacchielli, M.B. Aravantinos (eds.), *Scritti di antichità in memoria di Sandro Stucchi*, vol. 1, Roma 1996, 281–292; H. LAUTER, *Ptolemais in Libyen. Ein Beitrag zur Baukunst Alexandrias*, "Jahrbuch des Deutschen Archäologischen Instituts" 86, 1971, 149–178; S. STUCCHI, *Architettura Cirenaica*, Monografie di Archeologia Libica IX, Roma 1975.

<sup>4</sup> The text is based on preliminary reports submitted to the Department of Archaeology in Tripoli and Benghazi following each season and presented on the website [www.ptolemais.pl](http://www.ptolemais.pl). Exact dates and names of team members can be found there.

<sup>5</sup> Cf. K. MISIEWICZ, *At search offorum at Ptolemais. Interpretation of results of geophysical surveys at the central part of the city*, (in:) E. Jastrzębowska, M. Niewójt (eds.), *Archeologia a Tolemaide...*, 133–145.

on transferring of most of the wall paintings from the House of Leukaktios to the Tolmeita (Ptolemais) Museum for conservation reasons.<sup>6</sup> Limited archaeological explorations were conducted within earlier trenches.

In Spring of 2007, a small room (R 59) was cleared (Fig. 8). It opened on an atrium (Unit 2/07 – debris layer, Unit 5/07 – accumulation layer on the floor level) and was found to be furnished with a floor of waterproof mortar set with two round mortared storage vats (Storage Vat V 6 – Unit 10/07 and Storage Vat V 7 – 11/07).<sup>7</sup> Blocks of stone standing on the pavement in the chamber R 59, three along the north wall (W 137) and two in the south-eastern corner, may have been connected with the use of the two storage vats (Fig. 9).

Traces of mortar on the west wall (W 106), preserving a characteristic herring-bone pattern, prove that the walls were finely plastered and perhaps also painted. Potsherds, which were usually put between the stones of the wall and the mortar, were also present. Threshold stones in Wall W 106 formed a step negotiating the difference in levels between the floor in the chamber R 59 and the courtyard (R 51).

The surviving floor and sections of walls did not reveal upon exploration any evidence for other doorways in this chamber. Only on the south side (W 105) the arrangement of stones could suggest a narrow, secondary passage to the neighbouring room (R 52) also situated by the atrium (Fig. 10).

The exploration of Room R 59 and the foundations of the plundered Wall W 137 cleared the way to the investigation of the eastern part of R 54. The room had a waterproof mortar floor and was in fact part of the courtyard (R 51), possibly a kind of portico, judging by the presence of two stone slabs under supports of some kind, possibly columns (Fig. 11).

A gap in the floor in the eastern part of the chamber R 54 permitted exploration of the underlying layers (Unit 3/07 – destruction layer, Unit 14/07 – accumulation layer). A fragment of a large terracotta dolium (diam. approx. 1 m) was discovered standing on the mortar floor in the level below R 59 (28.6 m a.s.l.). It must have been used from the atrium (29.07 m a.s.l.) as there was no entrance in Wall W 143. The levelling layer with stone bedding under the pavement of the chamber R 54 did damage to the jar, indicating that it belonged to an earlier phase of the architecture. A coin (inv. No. Cn/18/07) was found below the occupational layer in the atrium. The mortar floor was missing in a section 0.4 m wide along Wall W 113 and the exploration finished on bedrock (Unit 14/07, 28.3 m a.s.l.).

The descent to the walking level of the floor with the dolium may have been located in this part (Fig. 12).

The pavement of the courtyard (R 51) turned out to be properly inclined in order to ensure the draining of rainwater into the central impluvium (Figs. 13, 14). This suggests the absence of roof supports from the original layout of the atrium, despite the column bases having been set up at the edges of the pool; the bases may have been added secondarily. The arrangement may have been determined by the presence of the large cistern with two mouths (C 4a, C 4b) under the courtyard. A stone channel drained excess water from the impluvium; in the chamber R 43 the channel branched off into the western street (Fig. 15). Another mortar channel made in the floor of the chamber R 54 led to the runoffs of the cistern in R 2 (C 1a) and in Wall W 113 (C 1b).

The chamber R 2 was uncovered already in 2002 (Fig. 16). A low puteal was set up on large slabs (1.43×0.27×0.15 m), closing the big rectangular cistern shaft (C 1a). The walking level in this room (Unit 25/07), identified in 2007, consisted of tamped soil. A mortar channel associated with this level ran in the south-western corner between the walls (W 17 and W 113) joining the two cistern openings. The levelling layer under the floor was made of rough white stone cobbles mixed with large quantities of pottery of Hellenistic date; the solidity of this substructure must have been determined by structural demands connected with the building of the cistern.

In the chamber R 32 of the House of Leukaktios the occupational level (28.13 m a.s.l.) consisted of tamped soil (Unit 23/07) and loose stone blocks grouped in the south-eastern part. The arrangement of the blocks was quite regular, suggesting that they represented part of a structure of some kind; it is also possible that the blocks came from the tumble of Wall W 75 (Fig. 17).

Sections of a regularly paved courtyard were recorded to the south side of Wall W 75; from the west they were limited by Wall W 140. The pavement lay on a level higher than that of the House of Leukaktios (29.03 m a.s.l.). Wall W 75 appears to have been levelled to the level of this pavement which was then used during the occupation of chambers R 32 and R 30 in a later phase (Figs. 18, 19). Further proof of this was supplied by a dressed block of stone set in such a way as to allow water to drain from this pavement down into R 32 (Figs. 20–22).

Wall W 140 limiting the pavement on one side turned out to incorporate threshold stones from an entrance leading into the chamber R 70, which was closed on the west side by Wall W 144 (Fig. 23). A narrow cistern

<sup>6</sup> See below: K. CHMIELEWSKI, *Salvage conservation of wall paintings in the House of Leukaktios*, 23–24.

<sup>7</sup> See below: Z. KOWARSKA, S. LENARCZYK, *Storage vats from the excavated houses*, 17–20.

opening (C 6) was found in the mosaic floor (M 15) opposite the entrance to the chamber. The cistern fill contained small quantities of heavily damaged potsherds, including three full Mid-Roman vessel forms (Unit 19/07). The exploration of Room R 70 (Unit 20/07) uncovered on the floor (29.03 m a.s.l.) a mosaic made of blue and white tesserae (M 15). The design of the border suggested the size of the room which was delimited on the south by Wall W 137. Even so, the mosaic floor broke off suddenly in the middle of the room, revealing Wall W 142 below (28.86 m a.s.l.), situated at right angle to Wall W 144. Its presence must have been due to a later rebuilding event in the southern part of R 70 (Fig. 24).

Brick debris (Unit 13/07), indicating the presence of a kiln (Fig. 25), was discovered to the south of Wall W 142 (Fig. 26), in an area ensconced between Wall W 139 on the west and Wall W 137 on the south (Room R 66). The external stone structure was found within an area set off by Walls W 139, W 137, W 142 and W 145. It was lined with a double row of vertically set bricks, all bearing fingerprints. The rounded edges of the bricks suggest a semi-circular vault. Further exploration, following the removal of the debris, revealed a two-part firing chamber founded directly on bedrock (28.37 m a.s.l.). The chambers have a surface area of approximately 3.5 m<sup>2</sup>, while the almost rectangular opening on the east side, set off by Wall W 145, was about 1.8 m<sup>2</sup> big. The walls of the structure survived to about 1.5–1.75 m above bedrock (Fig. 27). Explorations inside the kiln revealed only a small amount of pottery, but farther to the east of the opening (R 69, Unit 21/07) a great deal of Mid- and Late Roman pottery was found.

Once the murals from the south wall of the triclinium (R 1) of the House of Leukaktios were taken down by restorers in Autumn of 2007, it became possible to continue excavations in the area of the room (R 70) where the furnace was later constructed. The chamber R 71, which was discovered then, had a thin lime-mortar floor poured straight on the ground without any stone substructure. The floor reached Wall W 75, of which nothing remained in place. The floor inside Room R 71 was on the same level as the mosaic floor in R 70 and it may have been a kind of annex to that chamber. Assuming, however, that a staircase was fitted into R 32, the room may have also been part of the House of Leukaktios.

The chamber R 48, which was also explored in Autumn of 2007, was a kind of tablinum situated on the axis of the courtyard. Fragments of wall paintings were preserved on Walls W 101 and W 102, next to the wide doorway from the atrium furnished with richly profiled jamb bases (Fig. 28). The width of the passage in excess of 2 m,

as well as the evidence of murals, suggested its official character. It had a separate entrance to Room R 50 (Fig. 29). Like the other rooms around the courtyard, this chamber (R 48) did not preserve any traces of a mosaic floor; the surface consisted of two thin layers of lime mortar laid straight on the ground. Underneath this floor there were the foundations of Wall W 130. It constituted a continuation of the wall in the room R 50 adjoining the western street and Wall W 148 with which it formed a corner. Together they gave the outline of a chamber (R 56) which belonged to an earlier, presumably Hellenistic phase of architecture in this part of the insula (Fig. 30).

The neighbouring room R 52, identified partly in 2007, was cleared in 2008; it turned out to have a wide passage (1.5 m) opening into the courtyard R 51 (Fig. 31). The wall that delimited it on the south is a continuation of Wall W 133. The absence of any doors on such a long distance suggests that the wall actually constituted the southern border of an atrium house (R 51 being the atrium). The walls of Room R 52 were composed of W 149 (= W 138) on the east, W 105 on the north, W 103 on the west and W 104 on either side of the passage into the courtyard (Fig. 32). One should note a different technique of construction of the southern section of Wall W 103.

The deposition sequence identified in the east baulk of a test pit (2×0.5 m) in the chamber R 52, cut at right angle to Wall W 133, was as follows: 1. topsoil and upper destruction layer (Unit 2/08); 2. destruction layers (Units 3/08 and 04/08 = 37/07) consisting of stones, fragmented mud bricks, mixed pottery and coins; 3. accumulation layer (Unit 5/08 = 40/07), mostly with Mid-Roman pottery, fragments of paintings, stuccos, singular white tesserae, mutilated stones and an architectural block; 4. lowest layer above bedrock (Unit 6/08 = 43/07) containing a few very fragmented potsherds, pieces of glasses and bones.

Behind a row of loose stones W 146 and W 147 (Unit 7/08) in the south-western corner of R 52, there was a hearth which contained ashes, bones, coarse ware pottery, glass, and burned wood. It was explored down to bedrock. It was a secondary feature above the original occupational level of the room.

The walls of the chamber R 52 were plastered and painted, although little has survived of the murals. A bigger fragment was located *in situ* close to the south-eastern corner, on the lower part of Wall W 149; it comprised a socle painted in imitation of marble and the bottom part of the central register composed of different colour panels and interpanels.<sup>8</sup> Painted plaster of similar character was preserved fragmentarily also on Walls W 103 and W 133.

<sup>8</sup> See below: J. ŻELAZOWSKI, *The painted decoration of the House of the Atrium*, 20–23.

The walls of this chamber were built in the same manner as those of the House of Leukaktios with the upper parts being made of mud brick and tamped clay. This has determined the state of preservation of the paintings and the discovery of many small fragments of plaster, especially in the vicinity of Wall W 149 (Unit 5/08).

A door lintel (**Fig. 33**) just 1.15 m long was found broken in two (inv. Nos A/267 and A/268) in the same layer, next to W 149. It featured a simple dentil decoration with partly preserved white-coated zones. Single white tesserae in the accumulation layer (Unit 5/08) suggest the possibility of a mosaic floor in R 52, destroyed during a later phase when the room was being used as a place for artisanal production which developed in this part of the insula.

Two round storage vats (V 4 – Unit 45/09 and V 5 – Unit 44/09) were sunk into the ground during this later phase in the north-eastern corner of the chamber and were used from the level of the earlier floor in Room R 52 with the mural decoration (**Fig. 34**). The storage vats were explored in 2009.<sup>9</sup>

Further rooms were discovered when excavations progressed eastward in Spring of 2008. The chamber R 72 (**Fig. 35**) was identified on the other side of Wall W 149; on the south side it was closed by a wall which continued on Wall W 133 (**Fig. 36**), albeit removed by 0.2 m to one side and featuring a different masonry bond (W 150). Walls W 152 and W 151 closed the room on the east and north respectively.

Ashes probably from a fireplace were found in the south-western part of Room R 72, set off on the southern side by an isolated block near W 150 (Unit 32/08). There were traces of ashes under the floor level (Unit 35/08). Centrally inside R 72 there was a round structure of unidentified purpose (Unit 13/08), made of fragmented architectural elements of limestone, column drums and soil, mixed with small stones (**Fig. 37**).

The division between Rooms R 72 and R 73 was marked by architectural spolia (a damaged dentil block partly coated white, inv. No. A/269, and a fragmented moulded doorframe, inv. No. A/270) placed above the lower part of Wall W 151 on the northern side (Unit 17/08). This occurred in a later phase connected with a change of function from habitational to artisanal, when the original wall was demolished. A posthumous coin of Constantine (Cn/049/2008)<sup>10</sup> found within the structure of Wall W 151 dates the construction to before the earthquake of AD 365.

The fill in Room R 72 consisted of the following layers (in the order of excavation): 1. humus and upper destruction layer (Units 02/08, 03/08) containing Mid-Roman pottery and a marble sculpture fragment; 2. destruction layer (Unit 8/08) composed of soil mixed with small stones, pottery and lamp fragments, many coins and metal objects; 3. destruction layer (Unit 14/08) consisting of soil partly mixed with ashes and small stones; 4. accumulation layer (Unit 26/08), superimposed directly on top of the next layer; 5. layer of hardened clay (Unit 033/08). A layer of ashes was recorded in the western part of the room (Unit 32/08).

Numismatic finds in Layers 03/08 (Cn/005/08–Cn/018/08), composed of numerous Ptolemaic coins mixed with Late Roman material, appear to confirm the Late Roman dating of the last occupation of the room. Two coins of Hadrian struck for Cyrenaica (Cn/019/08 and Cn/025/08) and a coin of Commodus (Cn/029/08) discovered in Layer 08/08 appear to date one of the occupational phases inside the chamber to the Antoninian period. One should note the presence of coins of the 1<sup>st</sup> c. AD in Layer 14/08: a halved as with the head of Augustus (Cn/041/08) and a quadrans of Domitian (Cn/026/08).

The corner of a large chamber (R 73), approximately 40 m<sup>2</sup> big, was discovered already in 2007 to the east of Wall W 138. A fragment of a mosaic floor (M 14) and a stone pavement (29.13 m a.s.l.) was also recorded at the time, along with superimposed accumulation layer (Unit 16/07). The chamber was delimited by Walls W 138, W 155 and W 151 on the west, north and south respectively. Two passages, blocked by the above described reused architectural blocks, connected it with R 72 (**Fig. 38**).

The original mosaic floor (M 14) was preserved in two small fragments by Walls W 138 and W 151. Traces of a bluish border on a white background could be observed. Damages made to this floor at some time necessitated its repair with loosely set stones forming a kind of pavement with original sides on the east, south and west. A rectangular platform of waterproof mortar (3.8×2.45 m) was introduced in the northern part of the room (29.27 m a.s.l.). Reused stone blocks limited it on the north and east (**Fig. 39**). Ashes found between two blocks could be the remains of a small fireplace. The platform had dressed edges and appears to have been set up directly on the pavement. It was doubtless part of the workshop installations operating in the chamber R 73, presumably already after the earthquake of AD 365.

<sup>9</sup> Cf. Z. KOWARSKA, S. LENARCZYK, *Storage vats...*, 19.

<sup>10</sup> The coins were identified by Piotr Jaworski who is studying the

numismatic finds from Polish excavations in Ptolemais.

The round mouth of a cistern (C 8) or large storage vat (Unit 11/08), featuring an inside diameter of 0.92 m, was discovered in the south-eastern corner of the chamber R 73 (Fig. 40). It was built of small irregular blocks of stone reinforced with a layer of mortar (width: 0.49–0.6 m). The fill consisted of potsherds in soil, mostly Mid- and Late Roman, bones and pieces of sun-dried brick. Moreover, the fill yielded fragments of a damaged architrave and a column base. A coin from the cistern (Cn/ 044/08) dated the archaeological assemblage to the end of the 4<sup>th</sup> and early 5<sup>th</sup> c. AD.

A small lime-burning kiln (Fig. 41) was also recorded between the cistern and Wall W 151. It proved to be partly damaged on the western side, but even so, it was clear that it was originally rectangular (1.2×0.85 m) and was constructed principally of mud bricks (approx. 0.2×0.15 m). A layer of lime 0.15 m thick (Unit 34/08) was found inside the kiln, including small pieces of marble coming possibly from floor revetment. The mixed assemblage also included glass vessel fragments, terra sigillata and relatively numerous sherds of cooking ware.

The fill inside the chamber R 73 comprised a number of layers of stones mixed with earth, considerable assemblages of Mid-Roman ceramics, lamp fragments and coins (Units 3/08, 8/08); above – floor accumulation yielded residual ash (Units 15/08 and 31/08). The layer stratigraphy and the overall characteristic of the finds, including coins, did not differ from that in the neighbouring chamber R 72, indicating several phases of use down to the end of the 4<sup>th</sup> and beginning of the 5<sup>th</sup> c. AD.

Further clearing of a regular pavement of large slabs (0.5×1.1×0.4 m) discovered earlier to the north of Wall W 155, in R 68 (Figs. 42, 43), uncovered a shallow rectangular pool in the middle. A mosaic floor of white tesserae (M 16) lined the pool (Fig. 44). The edges of the impluvium were formed of regular blocks of stone arranged in such a way so as to hint at the presence of supports, most probably columns, supporting the roof around it. An accumulation layer was distinguished directly above the mosaic floor (Unit 20/08). The pavement was one step down, approximately 0.2 m, from the level of the floor in R 73. Traces of the step could be observed in the western part of Wall W 155 (specially cut block 1×0.4×0.15 m).

The original paving of the courtyard undoubtedly reached Wall W 140 of Room R 70, but the slabs were missing from the south-western corner of the courtyard presumably owing to the presence of a large ceramic furnace

(K 3) that was founded directly on bedrock in this spot. Moreover, excavations revealed the remains of another, this time small (1.2×0.7 m) pottery furnace (K 4) located with the opening at right angles to the bigger one; the vault in this case was not preserved, and the side walls stood to a height of 0.85 m (Fig. 45). There is no doubt that the original impluvium was used intentionally as a location for the furnace, two low walls (W 154 and W 141) having been raised directly on the mosaic floor. The mutual positioning of the furnaces (K 3 and K 4) suggested their simultaneous use. Nothing much was found inside the furnace chambers except for an insignificant quantity of Mid-Roman pottery in the smaller one of the two.

Investigations were also carried out in other parts of the insula as a follow up on earlier research despite the fact that starting from 2008 the main thrust of the exploration was directed on the architecture of the insula going east.

In the northern part, more investigations were conducted on a large apsed hall with high standing walls (R 65, approx. 103 m<sup>2</sup>) in an effort to determine its function (Fig. 46).<sup>11</sup> A rubble deposit of crushed stone blocks was removed down to the level of 27.68 m a.s.l. It probably came from the walls of the chamber which were of not very big blocks facing the wall core. Unlike the long walls, the walls of the apse which were built into a rectangular outline were constructed of large rectangular blocks.

Two doorways approx. 0.85 m wide each could be observed in the west wall of the chamber (W 121, W 123, W 124) leading to as yet unexplored Rooms R 26 and R 57. A similar arrangement was observed of the east wall (W 94, W 122).

The rubble inside the apse contained several large stone blocks which must have come from its walls. Architectural elements were recorded also inside R 65, e.g., a spirally fluted marble column shaft (inv. No. A/263) in the north-eastern corner (Fig. 47) and a fragment of an architrave (inv. No. A/ 260) of late antique date to judge by the manner of dressing, which must have originated from a tripartite arch above a central doorway if the characteristic finishing of the right side is anything to go by. Traces of white plaster with evidence of red and green paint were preserved on some of the blocks. The fill contained not much pottery, a few fragments of bricks, marble slabs and coins.

The apsed hall may have been part of a late antique private residence or a small Christian church, although it

<sup>11</sup> Cf. E. JASTRZĘBOWSKA, *Le basiliche cristiane sconosciute nel centro della città di Tolemaide*, (in:) E. Jastrzębowska, M. Niewójt

(eds.), *Archeologia a Tolemaide...*, 226–238 (particularly 233–235).

is too early at this stage of the research to determine which interpretation is true. It was undoubtedly the latest architectural phase in the insula, its walls having been founded on the occupational level of an earlier house of some substance, but without respecting the layout. The house was in ruins and indeed partly filled and partly dismantled at the time that the hall was constructed. Thus the absence of continuity between successive structures was stated.

In spite of the fact that the structure uncovered in this part of the excavations, especially the large hall with the geometric mosaic floor (Fig. 48), belonged to a residential complex evidently on a lower occupational level than that of the House of Leukaktios, clearing work was undertaken all the way to the western street in order to define the borders of the insula. The exploration was contained between Walls W 1 on the west, W 71 on the east, W 70 on the south and W 43 on the north. An extension of Wall W 1 was found to mark the western insula limits. The wall was preserved only at the foundation level, the rest of it having been dismantled and removed. A single stone threshold block which appeared to be undisturbed may have been a wide street entrance to the chamber R 74.

The circular mouth to a huge cistern (C 10) was found just inside the entrance, covered by a large rectangular stone slab. It turned out to be by Wall W 166, which extended at the right angle to Wall W 1. The part W 1 to the south of the latter wall was labelled as Room R 74 (Fig. 49). The exploration uncovered a stone paving level composed of loosely arranged irregular slabs and blocks. Interestingly, the stones in the north-eastern part were arranged in a semicircle, outlining a feature which should be studied. Inside it there was a hearth full of ashes, fragments of burned wood and burned bones. At the southern end a row of separate blocks (W 72) set up on the end next to Wall W 71 suggested the presence of some kind of stone bench (Unit 46/08).

Recorded layers included a destruction layer (Unit 38/08), that is, soil mixed with some fragments of mud brick and Mid- and Late Roman coarse pottery, followed by burnt layers of soil mixed with ashes and fragments of burnt wood, bones and pottery, in the north-western corner (Unit 39/08) and the centre (Unit 43/08) of the chamber R 74 respectively. An accumulation layer (Unit 50/08) was also distinguished superimposed on the stone pavement in R 74. It was a hard beaten earth and hardened clay level mixed with small fragments of pottery, bones and mortar. A layer (Unit 52/08) was also recorded under the stone pavement in the western part of the room.

To the north of Wall W 166, which was pierced by a doorway leading to R 79 in the corner with Wall W 71, there was yet another door with a well preserved threshold, aligned with the first one and opening into the northernmost of the identified chambers, i.e., R 76 (Fig. 50). An irregular section of floor made in the *opus signinum* technique was found in the south-western corner of R 79.

The floor was caved in a little. Tumbled stones lying on a mortar floor (Unit 30/09) were cleared there in the 2009 season (Fig. 51).

Wall W 160 of the chamber R 76 retained some traces of painted decoration on the northern face, unfortunately only partly preserved. An octagonal column base (inv. No. A/288) and two other architectural blocks (inv. Nos A/289, A/290) were found in the central part of the room (27.21 m a.s.l.). In the north-eastern corner a low partition of small stones bonded together with mortar closed off the area from the east, running at an angle to Walls W 43 and W 71.

The stratigraphy in the chambers R 76 and R 79 proved to be largely congruous: first, an upper destruction layer (Unit 63/08), that is, soil mixed with stones and mortar, broken frescoes, a huge amount of pottery and bones, under which there was a layer of hard beaten soil and clay (Unit 64/08). A burned layer (Unit 65/08) distinguished in the northern part of R 76 may represent the remains of a hearth: soil mixed with ashes, burned wood, burned pottery and bones. An accumulation layer of soil mixed with stones and pottery (Unit 66/08=26/09) was found below it. It proved to overlie an accumulation layer with soil and ashes (Unit 28/09), the latter having been deposited on top of a mosaic floor (Unit 34/09). This layer yielded coins, fragments of lamps, glass, metal objects and small pottery sherds. The mosaic which had a geometric pattern was poorly preserved, especially due to damages caused by later occupation of the room. Blocks from the west wall (W 1) lining the street were removed in a later phase of occupation of the chamber.

In a phase postdating the residential architecture these two chambers were undoubtedly reused from the side of the street, but even so their layout appears to reflect the original layout of this part of the house which is presumed to have been entered from the western street.

In the Autumn season of 2008 excavations concentrated in the eastern part of the insula in an effort primarily to trace the eastern street and identify the architecture along the whole width of the insula occupied by the House of Leukaktios. Determining the actual width of the insula in this part of the town was also important from the point of view of the topographic studies being carried out by the team.

Earlier work in the house already identified a few passages leading in different phases out of Room R 5 and into a courtyard in the eastern part of the insula. This courtyard (R 46) had a floor of lime mortar with small pebbles and was furnished with a cistern (C 5, Unit 1/07), which was explored already in 2007 (Fig. 52). A large quantity of Mid- and Late Roman pottery was found in the fill of the cistern, as well as two fragments of lamps and one coin (inv. No. Cn/14/07). A small pottery kiln (K 1) was found there (Fig. 53), superimposed directly on top of a mosaic floor (M 13) in a room (R 45) adjacent to the courtyard (Fig. 54).

The excavations followed walls W 45 and W 73 on the north and south side respectively, reaching the presumed eastern limits of the insula (Fig. 55). Wall W 157 was discovered almost immediately. It was situated N-S alongside the eastern street bordering the insula. The face of this wall from the House of Leukaktios was 36.61 m away from Wall W1, closing the house from the western street (Fig. 56). The small irregular stones bonded in clay mortar making up Wall W 157, preserved in 3–4 courses, suggest its function as an enclosure wall rather than a structural feature. To the west of it there was some kind of stone paving connected with the wall (Unit 40/08).

The underlying layers (Units 37/08, 41/08, 44/08, 47/08, 48/08, 51/08) reflected a destruction sequence. Finds included many coins and lamps (still to be dated precisely) and a great deal of Mid- and Late Roman pottery fragments, some marble vessels, fragments of *opus sectile*, and many lead objects. Layer 47/08 attests to a fire that may have consumed this part of the house (Fig. 57).

Architectural structures started to emerge on the level of the ruins of the House of Leukaktios. The courtyard with a cistern (R 46) was bordered on the south by Wall W 108; it was reconstructed apparently for the purposes of building the ceramic kiln, but stone blocks from the original construction remained in the bottom part, on the level of the mortar pavement of the courtyard. A threshold was recorded marking the passage into a room (R 45) with a mosaic pavement (M 13) and the later kiln (K 1). Another threshold in the same wall led into the small Room R 75 on the south; this chamber was occupied later by two circular containers (V 1, V 2) lined with waterproof mortar inside and reinforced with stones at the mouth.<sup>12</sup>

The room was fitted with stone blocks forming either some kind of pavement or an occupational level. Stone slabs forming a flooring (R 77) were also discovered to the east and just behind R 75; access to the containers appears to have been from this direction. A huge Wall W 107 bordered both rooms (R 45 and R 75) on the south; this wall was reconstructed at some point and was less regular even with R 77 (W 162).

The east wall of the courtyard with a cistern, W 159, was also the eastern limit of R 75. A big threshold in this wall served as an entrance into the courtyard and by the same also into the House of Leukaktios. The ground between the courtyard and the eastern street was paved with stone slabs, many of them having been reused and set with gaps between individual slabs (Fig. 58).

The two stone pavements (R 78 and R 77) reached the eastern street, the limits of which were marked by Wall W 164, of which only the level of the foundation was discovered. The single partly preserved course of huge rectangular blocks, which has survived of this wall, resembles closely Wall W 1. The blocks were laid straight on bedrock in the Hellenistic period as evidenced by a fine Gnathia sherd and a small Ptolemaic coin. Walls W 164 and W 1 on the opposite sides of the insula, set 36 m apart, have given the width of an insula from the Hellenistic period, possibly reflecting the original, Ptolemaic plan of the city. Practically the only other Hellenistic city block measured in Ptolemais is the insula of the Palazzo delle Colonne. It is of importance for topographic and urban studies of early Ptolemais in view of the fact that most of the standing and well preserved architecture dates from the Late Roman period.

Explorations of the courtyard with a cistern (R 46) revealed at least two phases of the mortar pavement, not counting spot restoration using small stones. The imprint of a column in the second-phase mortar near the cistern testifies to the use of column bases, capitals and shafts as tables and seats. Cleaning of the courtyard yielded a few coins, but it should be kept in mind that they could represent an accumulation layer. Immediately in front of the threshold leading into the street the mouth of a round container of waterproof mortar was found, with the opening reinforced with small stones (V 3).<sup>13</sup> Its use could not have been simultaneous with the use of the entrance from the street.

Wall W 165 ran under the mortar pavement of the courtyard, perpendicular to Wall W 48 and showing through at different points. Its line was traced also partly in the mortar and maybe under the stone pavement R 77, suggesting that originally the wall reached the street and that the layout of this part of the house was different. Yet the presence of a cistern with a large mouth (C 5) close to this wall appears to exclude the notion of there being another room behind R 5 (Fig. 59).

Considering that the mosaic floor level in R 45 was recorded below that of the courtyard, it is possible, but not mandatory, that the room was part of the original house layout. The mosaic (M 13) was made of rather big white tesserae and still preserves the T-shaped outline of the lost central paneau. A pottery furnace (K 1) and related walls were found lying on the floor, but there was also evidence of stones tumbling from a certain height.

Further work in the courtyard (R 46) in Autumn of 2009 covered an area between Walls W 47 and W 61 on

<sup>12</sup> Cf. Z. KOWARSKA, S. LENARCZYK, *Storage vats...*, 17–18.

<sup>13</sup> Cf. Z. KOWARSKA, S. LENARCZYK, *Storage vats...*, 18–20.



the western and the eastern border of the insula marked by Hellenistic Wall W 164 and the later Wall W 157. To the north the exploration reached a line marked by Wall W 168 (= W 114), covering the entire length of the lot occupied by the House of Leukaktios. It turned out that there were two rooms (R 80 and R 81) with mortar floors to the north of the courtyard, fitted between Walls W 167 on the side of the courtyard and W 168 at the northern end (**Fig. 60**). Wall W 61 on the west side of R 80 was constructed later without interconnecting with Walls W 47 and W 168, which could point to a different organisation of space in this part of the house in an earlier phase. The same can be said of Wall W 171 closing R 80 on the eastern side.

A number of destruction layers (Units 10/09, 27/09, 38/09) were distinguished in the fill of these rooms, including lamp and pottery fragments, metal objects, glass, tesserae and coins. The extensive presence of small pieces of wall painting collapsed from the walls is notable. Considerable amounts of clay in the layers reflected typical wall construction techniques employing mud bricks for the upper parts of the walls; this naturally conditions the poor state of preservation of the wall decoration.

The accumulation unit (55/09) immediately above the floor of *opus signinum* yielded finds in the form of few potsherds, 2 pieces of lamps, a small metal object and a few stone blocks (inv. Nos A/280, A/282). A profiled base (inv. No. A/281, dimensions: 1.12×0.47×0.6 m) in the north-eastern corner may have been used for a statue (**Fig. 61**).

The chamber R 80 was connected not with the courtyard but with the neighbouring Room R 81 to the east through a wide doorway in Wall W 171. This room was delimited by Wall W 168 on the north, Wall W 167 on the south and by a wall parallel with W 170, mostly dismantled, on the east. Behind this wall there was one more room with a partly preserved *opus signinum* floor.

The doorway between R 80 and R 81 (**Fig. 62**) consisted of two decorated blocks (inv. Nos A/1009, A/1010) with a *denticuli* ornament along the inner edge and a moulding on the outer edge (view from R 81), forming the lower part of the jambs in situ. The width of the entrance suggested an arch instead of a simple flat lintel. Wall W 167 separated the two rooms (R 80 and R 81) from the courtyard R 46. Two stone doorway thresholds have survived in position, but the one blocked by Wall W 171 belonged to an earlier phase.

The destruction layers distinguished in the fill of R 81 (Units 10/09, 27/09, 38/09) contained pottery, fragments of lamps, glass, metal objects and coins, small stones, mortar, stuccowork fragments and tesserae. A large fragment of a wall (the upper part of W 167) made of dried bricks, plastered and covered by paintings (Unit 57/09) was found in the eastern part of R 81. The accumulation layer identified below these units (Unit 58/09) lay on an *opus signinum* floor (Unit 59/09).

The upper part of Wall W 168 was also made of dried bricks. A tumbled section of the wall was found in the debris covering the northern part of R 81 (Unit 52/09). Reliable measurement of brick dimensions was not possible owing to the fragmentariness of the remains. This part of the wall was covered with white, very fine plaster applied directly to the brick surface, producing a smooth surface ready to be painted. Modest fragments of painting still adhered to one side of this wall. A few large stone blocks (inv. Nos. A/283–286) found near Wall W 168 may have been part of it; one of them (A/283) still bore a painted surface, another one (A/286) is stuck partly in the northern baulk of the trench.

Wall W 167 turned out to be the northern border of a large courtyard (R 46). The sequence of layers distinguished in the northern end during exploration in the 2009 season (Units 10/09, 22/09, 27/09, 35/09, 38/09) paralleled those identified in 2008 in the southern part of the courtyard.

An extension of the later Wall W 157, destroyed in the northern part, was discovered in the area of the eastern street. It was composed of three to four courses of small, irregular stones bonded in clay mortar. An irregular stone paving discovered in relation to this wall (Unit 17/09) could evince some kind of post-antique occupation of this zone (Unit 10/09 = 41/08). Underlying it was a thin layer (Unit 22/09) and below that another layer (Unit 27/09) with a characteristic concentration of mortar, stucco and tesserae in the south-eastern part of the trench. On this level (28.91 m a.s.l.), the upper part of a cistern inlet (C 7a) was found, blocked by irregular stones of different dimensions, including a fragment of a jamb (inv. No. A/287). There were two other stonework-lined openings leading to the big cistern, but positioned northward of the first (C 7b, C 7c).

A 20 cm thick layer of ashes mixed with soil occupied the south-western part of the trench (Unit 35/09); it appears to be industrial waste rather than evidence of burning. Below it was another substantial layer (Unit 38/09) saturated with pottery, mortar, glass, lamps and tesserae (28.96–29.32 m a.s.l.). The underlying accumulation layer (Unit 41/09) was filled with pottery, wall painting fragments, glass, lamps and metal objects. It was deposited on top of the occupational level on hardened earth with mortar (Unit 46/09). The layer immediately underneath (Unit 47/09) contained a small amount of pottery, bones and one coin. Wall W 170 closed the courtyard R 46 from the east. It was joined at the right angle by Wall W 169 from the street, setting off to more rooms with partly preserved mortar floors (**Fig. 63**). A layer of ashes (Unit 56/09) filled one of these two rooms.

The research until now has cleared about a quarter of the insula in the central part, tracing the entire House of Leukaktios, a small living unit in the southern part and considerable sections of two other houses, as well as late antique architecture in the northern part of the insula. The resulting picture is of the insula packed with medium-size houses, contributing substantially to knowledge of the

urban architecture of Ptolemais other than the great residences explored hitherto.

### Storage vats from the excavated houses

(Zofia Kowarska, Szymon Lenarczyk)

Excavations by the Polish team in the different houses occupying the insula have uncovered to date seven circular storage vats sunk into the floors of various rooms (Fig. 25). They are located in the eastern part of the House of Leukaktios: one (V 3) in the big courtyard, R 46 (Fig. 64), two (V 1, V 2) in the adjacent Room R 75 (Figs. 65, 66) and four in two adjoining rooms: two (V 4, V 5) in R 52 (Fig. 67) and two (V 6, V 7) in R 59 (Fig. 8) of the so-called House of the Atrium. The storage vats were found in 2007–2008 and their fill was explored mainly in 2009. The numbering of the storage vats reflects the order in which they were excavated.

In spite of certain differences in the size and depth, all seven of the storage vats follow the same model. They were sunk in the floors which were made usually of waterproof mortar. Only the storage vats in R 75 had a kind of cobbled pavement made around it. They were from 1.95 m to approximately 3 m deep, the diameter of the mouths oscillating between 0.86 m and 1.06 m. In all of the storage vats there was a kind of narrowing ledge at approximately two-thirds of the height, diminishing the diameter of the lower part of the storage vat. The ledge may have been used to separate the top part from the bottom part of the storage vat or to mount a sieve. The walls are lined with waterproof mortar, providing a hint as to the function of the storage vats as containers for holding or processing some kind of liquid substances. Moreover, all the storage vats were furnished with the same kind of low rim around the mouth, usually reinforced with flat stones of medium size. A depression below the mouth edge was prepared to hold the lid.

#### The storage vats in the House of Leukaktios (in the courtyard R 46 and in the chamber R 75)

The round storage vats of waterproof mortar set in the floor of the courtyard R 46 and Room R 75 were

explored in 2009. They should be interpreted as connected with a reoccupation of this part of the house for artisanal manufacturing processes. Storage Vat V 3 (Unit 16/09) in the courtyard was about 1.95–2 m deep, like the storage vats in R 75. The mouth was approximately 1 m in diameter. A characteristic narrowing of the diameter by about 0.10 m can be observed approximately 1 m above the bottom. Storage Vats V 1 and V 2 occupied practically the entire area of Room R 75 which opened onto the courtyard R 46. This could suggest that they were used only when the walls of R 75 had already been dismantled. Interestingly, no mortar floor was introduced around them; instead, a cobbled paving was made within the limits of R 75. Both were 1.95–2 m deep, the mouths measuring 1.06 m across, the narrowing of the inside diameter to 0.88–0.9 m being located approximately 0.80 m above the bottom.

#### Storage Vat V 1 (southern one)

The fill of the southern one (Figs. 68, 70) of the storage vats (Unit 14/09) consisted of a number of layers, the latest of which (Units 03/09, 06/09, 07/09) was characterised by a relatively small quantity of kitchen ware including both Hellenistic and Mid- and Late Roman material.<sup>14</sup> A few fragments of decorated tableware were found among the mostly common wares,<sup>15</sup> including fragments of Eastern Sigillata A, f. 8, Italic Sigillata, f. 18 (?), Eastern Sigillata B, f. 70, and two pieces of African Red Slip, f. 50A and f. 61 B, as well as Phocaeen Red Slip Ware (Late Roman C Ware), f. 1 D. The assemblage of finds from the layer also included a few lumps of charcoal, three pieces of glass vessels, a lamp fragment and pieces of wall paintings, as well as five metal object fragments, including a spearhead (inv. No. Mt/019/09, Fig. 69:12).

The underlying layer (Units 08/09) was mixed with stones of different size and three small blocks of stone, as well as many fragments of kitchen vessels and amphorae (including Late Roman Amphora 11)<sup>16</sup>. Despite the extensive chronological range (sherds of Black Glazed Campana A and Eastern Sigillata A, f. 3, as well as African Red Slip Ware, f. 50 A), the predominant assemblage was Mid- to Late Roman (especially many forms of cooking pots of late date, e.g. D 538, D 538–542 and 554, D 540, dated to the

<sup>14</sup> Terms referring to the chronology of coarse wares as well as references to specific forms follow the ones developed for Sidi Khrebish owing to the similarity of shapes occurring at both sites, cf. J.A. RILEY, *Coarse pottery*, (in:) J.A. Lloyd (ed.), *Excavations at Sidi Khrebish Benghazi (Berenice)*, vol. II, Supplement to *Libya Antiqua* V, Tripoli 1978, 91–467.

<sup>15</sup> Krzysztof Domżałski kindly identified the fine ware pottery material from Polish excavations in Ptolemais (cf. E. ETLINGER

ET AL., *Conspectus Formarum Terrae Sigillatae Italico Modo Confectae*, *Materialien zur Römisch-Germanischen Keramik* 10, Bonn 1990; J.W. HAYES, *Late Roman Pottery*, London 1972; idem, *Sigillate Orientali*, (in:) R. Bianchi Bandinelli, G. Becatti (eds.), *Enciclopedia dell'arte antica classica e orientale. Atlante delle Forme Ceramiche II, Ceramica Fine Romana nel Bacino Mediterraneo (Tardo Ellenismo e Primo Impero)*, Roma 1985, 1–96).

<sup>16</sup> Amphora typology after J.A. RILEY, *Coarse pottery...*

5<sup>th</sup>–6<sup>th</sup> c. AD). Also found was a glass vessel fragment (inv. No. g/009/09, **Fig. 69:14**), five bone pins, three pieces of metal objects, part of marble revetment, two pieces of lamps and three fragments of three different lamp moulds (inv. Nos: 1/008/09, 1/009/09, 1/010/09, **Fig. 69:7–9**); moreover, there were three late antique coins (inv. Nos: Cn/015/09, Cn/018/09, Cn/025/09).<sup>17</sup> The assemblage also contained a few dozen body sherds and handles from unbaked vessels.

The next layer was a thin deposit of soil mixed with ashes and lumps of charcoal (Unit 09/09, 27.53–27.38 m. a.s.l., **Fig. 70**). The assemblage consisted of a few dozen potsherds, mostly from Mid-Roman vessels bearing evidence of burning, as well as two pot stands (cf. D 959), fragment of a metal object and an intact oil lamp (inv. No. 1/013/09, **Fig. 69:10**), presumably locally made in the late period.

Below the ashes but still above the storage vat bottom (27.16 m. a.s.l.) there was a deposit of unbaked clay or clay matrix of a dark brown to chocolate colour, high plasticity and evident temper of whitish or yellowish colour, the round non-organic grains oscillating in size between 0.001m and 0.005 m. Large quantities of thin straw of some kind could also be observed.

The unbaked clay yielded also a few dozen pieces of unbaked vessel fragments (**Fig. 69:1–6**),<sup>18</sup> mostly pieces of round-sectioned amphora or table amphora/jar handles, as well as characteristically ribbed body sherds from such vessels. Pending lab analyses, the unbaked vessel fragments appear to be made of the same clay as the unbaked clay deposit found in the storage vat – same colour, texture and temper. A few dozen analogous pieces of unbaked vessels were also present in higher-lying deposits.

#### Storage Vat V 2 (northern one)

The fill of the other storage vat in R 75 (Unit 15/09) was similar, although less layers could be distinguished. The latest accumulation (Unit 02/09, 28.44–28.32 m a.s.l.) was characterized by small irregular stones. The underlying deposit consisted of soil with ashes (Unit 04/09, 28.23 m a.s.l.).

The ceramic assemblage resembled that from the first storage vat: except for a few sherds of Hellenistic and Early Roman wares (including a fragment of rim from an Early Roman Amphora 8 vessel), the predominating component was made up of vessels of Mid-Roman date, mostly jars (D 1145, 1168), cooking pots and amphorae (Mid-Roman Amphora 12). The cooking pot shapes are slightly

different from those recorded at Sidi Khrebish. There was also a few dozen pieces from a large pithos of local make, an amphora stopper, fragments of lamps and lamp moulds, glass vessel shards and three metal object fragments.

The ashes deposit lay on top of a thick layer (approx. 0.75 cm) of unbaked clay matrix (Unit 05/09, **Fig. 71**), which went down to the bottom of the silo (27.07 m a.s.l.). This layer is analogical to Unit 12/09 in the other storage vat in R 75. It also contained fragments of unbaked vessels (**Fig. 69:1–6**), six coins (late antique – inv. Nos.: Cn/007/09, Cn/009/09, Cn/010/09, Cn/011/09, Cn/021/09 and one Ptolemaic – Cn/006/09), as well as a few fragments of an unidentified clay object (inv. No. Oth/002/09) resembling the handle of a large vessel (?). The colour, structure and temper of the clay resembled closely the clay from Storage Vat V 1, hence they can be considered as proof of the simultaneous use of the two storage vats. Finds of baked pottery from the clay layer included a few dozen of small sherds from Hellenistic, Mid- and Late Roman jars (D 1102, D 1168, D 1145).

#### Storage Vat V 3 in the courtyard R 46

The fill of Storage Vat V 3 (Unit 16/09) from the courtyard (**Figs. 72, 73**), situated directly by the entrance from the street, consisted of a number of layers. The latest (Unit 11/09) was characterized by large irregular stones and a small quantity of coarse pottery as well as two late antique coins (inv. Nos.: Cn/024/09, Cn/032/09). The next accumulation (Unit 20/09) contained, more or less at mid-height of the storage vat, ashes and many animal bones situated above two large stone blocks (inv. Nos.: 278, 279). Underlying this was greenish soil (Unit 21/09) with traces of clay, remains of charcoal, two bone pins and dice (inv. No. Oth/011/09, **Fig. 69:11**), as well as numerous pottery, glass fragments, marble facing, lamps. The next layer (Unit 23/09) was immediately above the bottom of the storage vat (26.45 m a.s.l.) and contained many fragments of pottery, a bone pin (inv. No. B/008/09, **Fig. 69:13**) and small pieces of mortar along with an almost completely preserved lamp.

Despite the chronological span represented by the pottery assemblage, the predominant forms of cooking ware, tableware and storage amphorae are dated to the Mid-Roman period. These were mainly cooking pots and jars: D 501, D 503, D 516, D 521, D 1145, D 1148 with variants, a few dozen fragments of amphorae (resembling Late Roman Amphora 2 or 12, Mid-Roman amphorae and Late Roman Amphora 2). The common wares included

<sup>17</sup> The numismatic material was identified by Piotr Jaworski.

<sup>18</sup> Preliminary archaeometric analyses of the unbaked clay and

fragments of unbaked ceramic vessels were made by Małgorzata Daszkiewicz in 2010.

also a few dozen Hellenistic and Early Roman forms (including a sherd from a small jar of Type D 645).

Fine wares were represented by a Hellenistic Black Glazed vessel base, a fragment of Eastern Sigillata B (f. 60), ESC f. 26 B, African Red Slip Ware, f. 2B, African Red Slip Ware, f. 33 (AD 200–250 plus), African Red Slip Ware, f. 50A, African Red Slip Ware, f. 181 b (?) and Colour Coated Ware originating probably from Cyrenaica.

Small finds from the storage vat included eight pieces of glass vessels, six fragments of oil lamps (inv. Nos.: L/011/09 and L/039/09), eight fragmented metal objects, two pieces of murals, a clay bead (inv. No. Oth/033/09), three bone pins, fragment of a weight and a stone projectile(?) (inv. No. S/017/09). Among the most interesting finds from this storage vat is a game dice.

### The storage vats in Room R 52

The construction of the two storage vats is almost identical. They were sunk into the hydraulic mortar floor and used from an earlier occupational level in R 52. Interestingly, however, the waterproof mortar used for these installations was poured around the mouths of these storage vats to form a rectangular platform approximately 0.1 m thick. It is possible that the storage vats were situated in a separate room. The floor in the north-western part of the area around the storage vats was evidently thicker and just noticeably higher than the floor level in the remaining part of the room, although profiled appropriately to prevent things from falling inside. The borders of the storage vat openings were also slightly raised (by about 0.03 m). The distance between the storage vats was about 0.85 m. They were of almost identical form and both approximately 3 m deep. The opening of V 4 measured 0.78 m in diameter, that of V 5 – 0.73 m. A groove approximately 0.1 m wide for a covering slab was found to run around each opening. About 1.80 m down, inside each of the storage vats there was a projecting ledge of stone, which narrowed the diameter of the lower chamber by about 0.20 m. It may have been used for another covering slab or a sieve of some kind. The storage vats broadened insignificantly towards the bottom which was flat in both instances.

### Storage Vat V 4 (western one)

There was practically only one layer filling the storage vat (Unit 36/09) and it consisted of greenish-dark brown soil mixed with small stones, chunks of lime mortar and fragments of wall paintings as well as occasional lenses of ashes. The assemblage contained many animal bones as well as large amounts of pottery of mainly Mid- and Late Roman date: cooking pots (Types: D 502, D 504–505, D 517, D 520, D 522, D 524, D 547 and D 563), jars (D 1148 and smaller variants, also types without parallels from the Sidi Khrebish site), tableware; bowls and situla (Types: D 875, D 879 and D 900), amphorae (Types: Mid-Roman Amphora 3 and Mid-Roman Amphora 7), and a few fragments of vessels from an earlier period (fragments of

amphora rims of Early Roman Amphora 6 and 12). The fragmentation of the pottery made sure identification difficult. Three coins (inv. Nos.: Cn/052/09, Cn/055/09 and Cn/056/09) were also found, along with three pieces of bone pins, a fragment of a metal object, three fragments of glass vessels and a small fragment of lamp.

### Storage Vat V 5 (eastern one)

The eastern storage vat (Fig. 74) had a more complicated stratigraphy made up of three different layers: a thick (28.29–27.39 m a.s.l.) layer of brown clay (Unit 37/09), a 30-cm layer of soil mixed with large amounts of pottery (Unit 39/09) and a layer of soil mixed with ashes, charcoal, animal bones and large amounts of pottery (Unit 40/09). Despite evident differences, the ceramic assemblage in particular layers appears to be fairly consistent in chronological terms. The predominant forms were fragmented cooking pots, tableware and transport amphorae from the Mid- and Late Roman period (fragments of jars: D 645, D 1145–1146, D 1148–1150, D 1164, cooking pots: D 502, D 504, D 506, D 515–518, D 521–522, D 547 and D 581, bowls and situla: D 875 and D 900 and amphorae: Mid-Roman Amphora: 11 and 17A and Late Roman Amphora: 2 and 11) and 400 body sherds of tableware, cooking ware and storage containers, as well as two pieces of roof tiles, D 732–733). Early Roman and Hellenistic sherds are in the minority (fragment of a cooking pot D 416, Early Roman Amphora 12 and a jar D 1116).

A few dozen sherds of both imported fine ware and locally made Colour Coated Ware, representing a broad chronological range, were also found in Storage Vat V5. They included Apulian Gnathia ware, Eastern Sigillata A, f. 42), including four of Hayes, f. 31 B, three sherds of African Red Slip Ware, Hayes, f. 32 B, fragment of Hayes, f. 50 A and two fragments of Hayes, f. 181 B. Finds from the storage vat included also two pieces of clay loom weights, a clay spindle whorl, a small fragment of a lamp, a few pieces of metal objects, including nail fragments and a hook, a few pieces of glass vessels and two fragments of marble revetment. Of interest is a large stone object (inv. No. S/058/09) with characteristic profiling, most probably a fragment of the storage vat lid.

### Storage vats in the chamber R 59

These storage vats paralleled those in the chamber R 52. The mouths of both storage vats have a raised edge around them, this edge being approximately 0.05 m high and fitted with four depressions on opposite sides to hold the covering slabs. A fragment of a presumed covering slab of this kind was found inside one of the storage vats. The diameter of the opening of the western storage vat (V 7) was approximately 0.76 m (plus the edge for the slab about 0.1 m wide). The diameter of the opening of the eastern storage vat (V 6) was 0.83 m (plus 0.09 m for the edge). While the bottom of the storage vats has yet to be reached

(excavations are made difficult by the considerable depth of these features), it is clear that they were about 3–3.5 m deep and were made slightly wider at the bottom. Interestingly, at a depth of about 1.8 m from the top inside both storage vats there is a projecting ledge of stone that could have been used to mount some additional construction. The mortared floor of the room is profiled in a way that does not permit direct flow of liquids straight into the storage vats. The inclination is a mere 0.015 m over a distance of 1 m. The storage vats are located centrally in the chamber, the distance between them being about 1.1 m.

#### Storage Vat V 6 (eastern one)

The fill of Storage Vat V 6 consisted of gray-brown soil (Unit 50/09), below which there was a layer of earth and ashes mixed with small stones. The pottery assemblage consisted of about 2000 sherds, mostly very fragmented body sherds of amphorae, cooking pots and jugs. The assemblage included a few fragments of plain Hellenistic tableware (fragments of jars and bowls of Types D 605, and D 613-614), Mid-Roman jugs (Types D 1145-trefoil jug, D 1148, and D 1150) and a piece each of Italic Sigillata and African Red Slip Ware, f. 32 B. Also discovered were three pieces of metal nails and a Ptolemaic coin (inv. No. Cn/118/09).

#### Storage Vat V 7 (western one)

The fill of Storage Vat V 7 (Unit 53/09) resembled to a large degree that of Storage Vat V 6, the sole exception being the presence of a few large irregular stones in the bottom part of the storage vat. Large amounts of heavily fragmented common wares were discovered, including an Early Roman jug (Type D 420), a fragment of Mid-Roman cooking pot (Type D 520) and a Mid-Roman bowl (Type D 875), as well as a small sherd of Hellenistic Black Glazed pottery and a fragment of a bone pin. To date only one Ptolemaic coin from the end of the 2<sup>nd</sup> c. BC (inv. No. Cn/028/07) has been found in the storage vat.

In recapitulation, it appears that all the storage vats were constructed inside chambers which had already lost their living function. They are all extremely similar and must have been used for storage of a liquid substance. Circular storage vats were also noticed in Ptolemais: in the

northern part of the Roman Villa and in the southern part of the Palazzo delle Colonne. They find close parallels in other Cyrenaican towns, e.g. the eight storage vats of this type found in Building A in Taucheira, all sunk into an *opus signinum* floor in one of the rooms (Room IV). Storage vats of this kind have also been recorded at Berenice, Kyrene and in Apollonia.<sup>19</sup>

It is difficult to say what exactly was kept in the storage vats as no production installations have been found in close proximity. If water is excluded, because it was usually collected in cisterns, and also oil because of the absence of any permanent elements of presses, then the only possibility left is wine, which may have been fermented inside the storage vats.

At present it does not seem that the storage vats were constructed in any relation to ceramic manufacture in the nearby pottery kilns. Nonetheless, the presence in two storage vats of unbaked clay and fragments of unbaked vessels could point to secondary use of the storage vats for clay scour, for example.

Undoubtedly, the storage vats and pottery kilns are proof that following the collapse of the House of Leukaktios in an earthquake event, this part of the insula lost its residential character and was turned into a craftsmen's quarter, conditioned most certainly by the presence of a few large water cisterns and access to water essential in production processes.

## The painted decoration of the House of the Atrium

(Jerzy Żelazowski)

Excavations carried out in 2006–2007 to the south of the House of Leukaktios uncovered a small living complex arranged around a central courtyard with a rectangular impluvium and the mouth of a large cistern (C 4a). Rainwater from the roofs was carried down a channel into the cistern in the northern part of the house, while excess water was drained away into the western street by a channel branching off from the main channel in Room R 43.

The complex follows a different alignment than the House of Leukaktios. The latter house was entered from the western street and occupied the width of the entire

<sup>19</sup> Cf. A.M. BUZAIAN, *Excavations at Tocra (1985–1992)*, “Libyan Studies” 31, 2000, 67–68; F. BENTAHER, A. BUZAIAN, *Roman wine production in Cyrenaica: New evidence from Balagrae (Al-Beida)*, (in:) M. Luni (ed.), *Cirene...*, 31–36; A. WILSON, *Urban Economies of Late Antique Cyrenaica in Economy and Exchange*, (in:) S. Kingsley, M. Decker (eds.), *The East Mediterranean during Late Antiquity, Proceedings of a Conference at Somerville,*

*Oxford, 29<sup>th</sup> May 1999*, Oxford 2001, 29–43. About wine production in Cyrenaica see also: E. CATANI, *Il Torculario e le celle vinarie della fattoria paleobizantina di Siret El Giamel nella chora cirenea*, (in:) L. Gasperini, S.M. Marengo (eds.), *Cirene e la Cirenaica nell'antichità. Atti del convegno internazionale di studi, Roma-Frascati, 18–21 Dicembre 1996*, Tivoli 2007, 125–156.

insula extending to the eastern street along the full length of the levelling. By comparison, the House of the Atrium did not reach even half the width of the insula where it was limited by another housing complex on the east, but it extended from north to south for the full length of the levelling lining the western street.

A hoard of coins discovered in Room R 50, containing the last issues of Trebonianus Gallus from the middle of the 3<sup>rd</sup> c. AD, set the chronological horizon for the existence of the building, suggesting simultaneously that it was destroyed in an earthquake.<sup>20</sup> The area of the house continued to be used for some kind of craftwork, presumably taking advantage of two big and still operational cisterns. A small metallurgical furnace was installed in the latrine (**Fig. 75**), four storage vats of waterproof mortar were sunk into the floor of two rooms (R 52, R 59) and a terracotta dolium was set up in R 44 opposite the earlier entrance from the western street (**Fig. 76**). These remains leave no doubt that the production activities were taking place on the courtyard level in the ruins of the house which was cleared and the walls were partly dismantled.

Interestingly, the southern part of the house (R 50, R 48 and partly R 52) remained an unused ruin, explaining how the hoard of coins went undiscovered. Moreover, the undamaged walls in this part of the house still bore painted decoration preserved in relatively good condition.

In the chamber R 50, where the hoard was found, remains of wall decoration were discovered mainly on the east wall, to the north of the door from R 48 (**Fig. 77**). The plaster coat was preserved on the wall to about 1 m above the floor. The coat turns up characteristically at the floor level, indicating that it had been laid once the floor, probably of tamped earth, was in place. The plaster layers proceeded unbroken onto the wall partitioning Room R 50, demonstrating the wall's origin in an earlier architectural phase.

Three painted layers can be distinguished on the east wall. Ground was applied directly to the stone blocks, followed by a painted layer (up to 1 cm thick) with later pockmarks under another layer of painted plaster (0.5 cm thick) applied directly without any ground. Sporadic traces of yet another thin layer applied on top of the second painted layer have been preserved in places. Little can be said of the character of the decoration and only with regard to the second painted layer which has preserved some motifs by the north-eastern corner of the room. Remains of vertical red lines (0.5 cm wide) can be observed 10 cm from the

corner. They are 16 cm apart and connect with horizontal lines set 20 cm apart to form a corner approximately 40 cm above the floor level. These lines could be the contours of a band of colour above the socle.

The panel formed by these lines contains traces of green paint on a white background. The next vertical red line can be seen on a projection of the wall approximately 90 cm away from the first one. This should therefore be considered as the panel width.

In the chamber R 48, which is situated on the axis of the courtyard, painted decoration has been preserved primarily on the north wall on both sides of the wide doorway from the atrium. Two painted layers can be distinguished, both approximately 1 cm thick and both on a ground layer.

The plaster on the wall to the east of the doorway has been preserved all the way to the corner (W 102) for 110 cm above the footing of the wall (**Figs. 78, 79**). The remains of the first painted layer can be observed with heavy pitting for the second layer of which very little has survived. Starting from the doorway there is a wide panel with irregular dark yellow, white and blue lines and splotches against a yellow background. The panel in the room corner (37 cm wide) featured a purple background with white and yellow dots, set off by a vertical yellow line (0.5 cm wide). Separating the two panels is a white band containing a sequence of vertical dark red and dark blue lines.

Both painted layers on the wall to the west of the doorway (W 101) have been preserved in better condition, the older one demonstrating extensive pitting under the later one (**Figs. 80, 81**). The former can be observed about 50 cm from the projection while the latter can be seen only for a distance of 67 cm from the corner.

In the first phase of the decoration a white band approx. 8 cm wide with a vertical blue line the width of a brush (0.5 cm) was the first to appear starting at the corner of the room. Next came a dark-blue line (1 cm wide) contouring a purple-pink panel with white dots, preserved for 90 cm in width. A similarly dark-blue line, 1 cm wide bordered the panel on the bottom. Below it there was a white band 6 cm wide with three very thin red lines. The next band below is dark blue with white dots, preserved to the wall projection at 18 cm above the floor, and maximally 50 cm high assuming that it ran from the footing. It is presumed to have been the socle of the wall decoration.

On the second, less well preserved painted layer there is a vertical white band approx. 11 cm wide, followed

<sup>20</sup> Cf. P. JAWORSKI, *Skarb z Ptolemais*, (in:) P. Jaworski (ed.), *Skarb z Ptolemais, Katalog wystawy, Zamek Królewski w Warszawie, 15 grudnia 2008–15 stycznia 2009*, Warszawa 2008, 40–50;

idem, *A Hoard of Roman coins from Ptolemais*, (in:) E. Jastrzębowska, M. Niewójt (eds.), *Archeologia a Tolemaide...*, 146–156.

by a red one 7 cm wide which forms a corner of a yellow-coloured panel at 21 cm above the projection in the wall. Below the horizontal part of the red line there is white plaster with either yellow staining from above or yellow lines.

Remains of painted decoration on the west wall of Room R 48, to the north of the door to R 50, have been preserved for approximately 1 m above the floor in the north-western corner (Fig. 82). The second painted layer has been preserved on this wall, because of a continuation of the above described decoration on the north wall of the room, but here it appears to have been applied directly to the blocks. It could mean that the first layer was removed completely.

Starting from the corner of the room, we observe a vertical white band followed by a green one (4 cm wide), which also runs horizontally outlining the corner of a yellow panel (preserved width 34 cm), contoured further still by white and red lines. In two places there are traces of yellow panels contoured with red lines, separated one from the other by white interpanels with small green motifs. Approximately 50 cm above the floor there is a socle composed of a horizontal white band with oblique blue lines.

Analogous decoration in the chamber R 52 consisted of a considerable section of wall painting (165 cm wide) preserved only in the lower part (76 cm high) on the east wall near the south-eastern corner (Figs. 83, 84). This layer is the first painted layer applied to a solid ground; pitting on the surface demonstrates that a second painted layer existed.

The socle directly above the floor, preserved to a height of 50 cm, is pink-white in colour with dark blue, white and red patches. A red line borders it on top and marks the vertical divisions of the socle. A light blue band above the socle is also used to contour panels and very narrow interpanels in the section higher up on the wall. Starting from the corner of the room, the decoration started with a white interpanel contoured with a red line, paralleled inside by another red line. A light blue panel follows, after which there is a yellow band between white and dark

blue lines framing a rectangular red panel. A white interpanel contoured in light blue separated it from the next panel coloured yellow and framed with a red band contoured in white. Thus, the colouring of neighbouring panels is reversed. The overall preservation makes it difficult to be sure whether they were monochromatic or else contained figural motifs of some kind.

The modest remains of painted decoration from the three most important chambers of the House of the Atrium confirm the commonness of this specific system of decoration in the urban houses of Cyrenaica. The scheme was to alternate panels and interpanels of different colours in the central register of the wall decoration. These were often monochromatic, devoid of figural motifs, and they ensured a rhythm to the arrangement and a play on contrasting colours.

The same decoration system was applied among others in the House of Leukaktios, in small rooms of a private nature on the north side of the peristyle (R 12, R 17). While relatively simple and cheap to produce, it was suitable also for decorating the public spaces inside houses. In the House of Leukaktios it can be observed also in the small courtyard (R 8) near the street entrance and in the official hall (R 9), where it constituted the first painted decoration preserved fragmentarily under later decoration with the bird images.<sup>21</sup>

The system was widespread in Ptolemais as indicated by vestiges in the so-called Roman Villa<sup>22</sup> and the Palazzo delle Colonne.<sup>23</sup> It is also attested in the House of Jason in Cyrene<sup>24</sup> and a nearby house (Casa del Peristilio Dorico);<sup>25</sup> it also seems to be present in Berenice.<sup>26</sup>

The cited examples correspond with the late Antoninian and early Severan dating of remains from the House of the Atrium, but this is hardly startling considering that this particular system of decoration, referring to the II and IV Pompeian style, became widespread in house decoration all over the Mediterranean from the times of Hadrian.<sup>27</sup> In this context, its occurrence in Cyrenaica is

<sup>21</sup> Cf. J. ŻELAZOWSKI, K. CHMIELEWSKI, *La decorazione pittorica nelle case di Cirenaica nel II–III sec. d.C.: continuità e trasformazione*, (in:) N. Zimmermann (ed.) *Akten des XI. Internationales Kolloquium der AIPMA, Ephesos 13-17.09.2010* (forthcoming); J. ŻELAZOWSKI, *Le pitture parietali della Casa di Leukaktios del III sec. d.C. a Ptolemais (Cirenaica)*, (in:) I. Bragantini (ed.), *Atti del X Congresso Internazionale dell'AIPMA, Napoli 17–21.09.2007*, vol. 2, Napoli 2010, 565–573; idem, *La pittura parietaria di una casa del III sec. d.C. a Ptolemais (Cirenaica). Note preliminari*, (in:) M. Luni (ed.), *Cirene...*, 205–211; idem, *Alcune considerazioni sulle pitture parietarie di una casa del III sec. d.C. a Ptolemais (Cirenaica)*, "Archeologia" (Warsaw) LVI (2005), 2006, 69–75.

<sup>22</sup> Cf. C.H. KRAELING, *Ptolemais. City of the Libyan Pentapolis*, Chicago 1962, 225–236.

<sup>23</sup> Cf. G. PESCE, *Il "Palazzo delle Colonne" in Tolemaide di Cirenaica*, Monografie di Archeologia Libica IV, Roma 1950, 40–41.

<sup>24</sup> Cf. P. MINGAZZINI, *L'Insula di Giasone Magno a Cirene*, Monografie di Archeologia Libica VIII, Roma 1966, 81–83.

<sup>25</sup> Cf. S. STUCCHI, *Architettura Cirenaica...*, 145, 314.

<sup>26</sup> Cf. D. MICHAELIDES, *Roman mosaic floors and wall-painting at Berenice*, (in:) J.A. Todd, D. Komini-Dialeti, D. Hatzivassiliou (eds.), *Greek archaeology without frontiers*, Athens 2002, 235–246; idem, *Wall paintings from Berenice*, "Kölner Jahrbuch für Vor- und Frühgeschichte" 24, 1991, 189–192.

<sup>27</sup> Cf. I. BALDASSARE, A. PONTRANDOLFO, A. ROUVERET, M. SALVADORI, *Pittura romana*, Milano 2006, 278–296.

not something locally specific, but proof of participation of this apparently distant region in the general development trends of wall painting in the Roman Empire.

The presence of imitations of marble revetment in the painted decoration of the House of the Atrium is also noteworthy. It occurs not only in the lowest parts as a socle, but also as panels of the central register in the first phase of the painted decoration in Room R 48. It is easy to recognize on the north wall the so-called porfido rosso or a variant of yellow marble (*giallo brecciato*).

This decoration system, present also in the House of Leukaktios,<sup>28</sup> has a long tradition in wall painting originating in the Hellenistic period and lasting through the end of antiquity, lapsing in popularity in different periods. Imitations of marble and other precious stones became fashionable again in the Severan period,<sup>29</sup> a fact that is corroborated by the presence of this decoration in both the House of Leukaktios and the House of the Atrium. This system contained an element of prestige and was used frequently in public house spaces as part of the owner's self-presentation even in such a modest house as the House of the Atrium.

### Salvage conservation of wall paintings in the House of Leukaktios (Krzysztof Chmielewski)

Considerable fragments of wall paintings were found in the House of Leukaktios already during the first excavation season in 2002. Regular excavations in the house revealed further sections of crumbling and damaged wall paintings, as well as sections where the painted layers were still preserved. Successively revealed fragments demonstrated geometric decoration with surprisingly intensive and contrasting colours.

The initial cleaning of the fill required extreme caution in order not to damage further the wall paintings while removing the fill with stones and broken architectural elements. The lime plaster coats were usually dangerously detached from the stone or clay ground of the walls. The parts adjacent to irregular losses were in particular danger of collapsing at the least touch. Reinforcing bands were placed on such friable edges successively as the paintings were cleared from the top down to floor level. The bands were made of mortar produced from local acryl putty with sand as filler, in 1:1 and 1:2 proportions. They had to be sufficiently strong in order to hold the plaster layers in

place, but weak enough to be removed easily in the future.

From the beginning it was assumed that the paintings would have to be taken down from the walls. Wherever the plaster cracked more seriously and soil and debris threatened to push out the fragments, temporary steps were taken in the form of a layer of cotton gauze attached to the surface with a weak solution of Paraloid B 72 in acetone. Once these spots were stabilized the preservation measures were removed. Wherever required, detached layers of plaster were consolidated with injections of a weak water solution of Primal AC 33.

The surface of the wall paintings was cleaned at once of hard and adhering layers of soil. Mechanical cleaning was accomplished with scalpels, toothbrushes, soft brushes, fibre glass and sponges. Spots where pigments tended to powder and come away at the touch of a finger (mainly red colours) were treated with special caution, the surfaces being saturated with a weak resin solution (Paraloid B 72 in acetone) to impregnate and reinforce the painted layer. Where possible, mechanical cleaning was followed by delicate washing with moist cotton tampon and water-saturated sponges. The same procedures were employed during successive excavations campaigns on all newly uncovered pieces of wall paintings. All the work was carried out in difficult climatic conditions and under time pressure.

The surviving murals differ in size, but for the most part they are fairly large fragments exceeding a metre in height above the floor and extending for more than a couple of metres in width. In many places (especially in Room R 1) successive layers (from 3 to 5) were preserved, testifying to successive phases in the redecoration of the house. All murals were made on lime plaster coats of varying thickness (from a few millimetres to about a centimetre); the *al fresco* technique was employed, although fragments appear to have been finished in the lime technique possibly using natural gums in the binder. The decoration for the most part imitates marble wall revetment characterised by simple geometric shapes and saturated colours from green, gray and light blue to yellows, pinks and reds. Professional brush strokes in many places imitate natural veining of the stone which taken together with the colouring easily identifies specific kinds of stone. A large fragment preserved on Wall W 3 in the corner of Room R 9 bore an illusionist rendering of architectural wall decoration and the image of a bird on a green panel between two columns. Of all the surviving fragments of murals this was the best painted piece both technologically and artistically.

<sup>28</sup> Cf. note 21.

<sup>29</sup> Cf. N. ZIMMERMANN, S. LADSTÄTTER, *Wandmalerei in Ephesos von hellenistischer bis byzantinische Zeit*, Wien 2010, 94–95,

165–172; A. BARBET, *La peinture murale en Gaule romaine*, Paris 2008, 263–292; A. BARBET (ed.), *Zeugma II. Peintures murales romaines*, Paris 2005, 55–67.



After each season the wall paintings had to be protected for the intervening year. The reinforced fragments were covered with synthetic fabric allowing evaporation, propped up with sand bags and backfilled with sand. These were temporary measures taken only until the conditions of storage could be stabilised and they could not prevent minor damages, detachment of the plaster in new places, fading of pigments and mechanical damages. Especially after the dramatic rainstorm of 2006 it became obvious that a transfer of the wall paintings to secure storage conditions was urgently pending.

In Summer of 2007 about 80% of the preserved wall paintings from the House of Leukaktios were taken down.<sup>30</sup> The process was preceded by detailed photographic documentation of particular walls and murals for the purposes of the transfer. All the selected fragments were also copied life-size on polyester film marking the borders of compositions and the divisions into transfer sections. Cutting lines between sections were planned depending on degree of adhesion of the plaster to the ground, the kind of ground (stone blocks or dried bricks), thickness of the plaster, composition of particular fragments of the decoration, and size of particular sections for transfer.

All painting surfaces were cleaned again with the same methods as used before. Where required the painted layer was reinforced again by impregnating with a weak synthetic resin (as above) and reinforcing bands were reintroduced as necessary. Losses of painted surfaces were filled with weak putty: acryl putty and sand for the bigger ones and chalk and sand with polyvinyl alcohol as binder for the smaller ones. The choice of a water solution of polyvinyl alcohol as an adhesive for the painting surfaces depended on technological factors (original fresco technique resistant to water) and rapid application on large surfaces in limited time. The painting surfaces were protected with layers of Japanese tissue, cotton gauze, diaper cloth and a final layer of cotton fabric (Fig. 85). The number of successive layers of tissue and cloth depended on what was required in a given spot. The concentration of the adhesive used ran from 15 to 25%. An antiseptic agent (Preventol) was added to the solution. After complete drying the cutting lines were transferred from the polyester film and the transfer sections were numbered. Thin saws and sharp knives cut through the layers of plaster along the marked lines.

The surface of the wall paintings was deformed in many places by cracking, collapsing and bulging in many places. In order to prevent further damages as the sections

were cut away and transferred to flat boards, the depressions in the surface were filled with polyurethane foam and covered on top with cardboard. This temporarily levelled the surface of the transferred sections of wall paintings.

The paintings were taken down by the stacco method (Fig. 86). Saws, knives, machetes, and long flat metal bars hammered in were used to cut away the paintings from the walls. This was done gradually with new tools inserted into gaps that became available. A board with a sponge lining, measured to fit, was placed against each transfer section and after the section had been cut away completely it was gently lowered to the ground. In the end each transfer section was resting face down on a separate board. The wall paintings were transported to safe storage in the Tolmeita (Ptolemais) Museum. The boards were set one on top of the other on wooden blocks that ensured proper space between each successive layer.

A total of 60 m<sup>2</sup> of wall paintings was transferred in this fashion. Of the bigger fragments only one section on Wall W 8 in the southern portico of the courtyard was not removed due to technical difficulties; it was much too thin and adhering too strongly to the ground. The rule was for the wall paintings to be taken down without separating the painted layers, although this transpired in a few cases.

In dry storage conditions the paintings can be stored in this fashion for the coming years. However, this does not mean that conservation procedures have been completed. The backs of the transferred sections should be reinforced, the sections turned face up and the protective sheeting and adhesive removed from the top. Selected murals can be placed on new transportable ground for display in the museum, especially the large fragment with the image of a bird from Room R 9 (Fig. 87). The remaining fragments after additional protection will be prepared for safe storage, serving at the same time as source material for studies on Late Roman wall painting.

### **Appendix. Preliminary physico-chemical analysis of samples of wall paintings from the House of Leukaktios (Elżbieta Rosłonec)**

The objective of the analyses was a preliminary identification of pigments, binders and determination of the composition of the mortar used in the painted wall decoration of the House of Leukaktios.

<sup>30</sup> Conservation work by conservators Krzysztof Chmielewski and Marcin Chmielewski assisted by students from the Academy of Fine Arts in Warsaw, Justyna Chałupka and Karina Sosnowska,

with extensive assistance from the staff and students of the Institute of Archaeology of the University of Warsaw.

The following analyses were carried out:

1. Microscopic examination in transmitted light with magnification max. 100×;
2. Microscopic examination in transmitted light with magnification 400×;
3. solubility in polar and non-polar solvents;
4. acid reaction (3M HCl, st. HCl and HNO<sub>3</sub>) and sodium lye reaction (4M NaOH);
5. typical microcrystalline reaction for particular non-organic ions;
6. EDS element identification (Roentec M1, Berlin) by electron scanning microscope LEC 435VP (Zeiss) with tungstic cathode counting approx. 1000pps, electron beam current 20keV.

Subjected to the analyses were two samples taken from the painted layer containing the following colours: red, green, white and yellow, applied to a white mortar in three layers on top of a beige ground still residually observable.

Layer stratigraphy:

1. Painted layer (Th. 0.05 mm) – composition: earth green, ultramarine, ochre, hematite, lime carbonate, vegetal black;
2. White mortar (Th. 10 mm) in three layers (3+3+4 mm) – composition: lime carbonate, ultramarine, vegetal black;
3. Beige ground (Th. 7 mm) – composition: lime carbonate, ochre, vegetal black.

Pigment identification based on element composition analysis and microscopic observation of water smears of samples in transmitted light. Results of element composition analysis by the SEM/EDS are presented in tabular form below (**Table 1**).

sition analysis by the SEM/EDS are presented in tabular form below (**Table 1**).

Sample No. 1:

- 1.1 green: earth green, ultramarine, ochre
- 1.2 gray: lime carbonate, earth green
- 1.3 white: lime carbonate, ultramarine
- 1.4 red: hematite, lime carbonate, ultramarine
- 1.5 yellow: ochre, earth green, ultramarine
- 1.6 white mortar: lime carbonate, ultramarine
- 1.7 beige ground: lime carbonate, ochre, vegetal black, kaolin clay.

Sample No. 2:

- 2.1 yellow: ochre, earth green, ultramarine
- 2.2 red: hematite, lime carbonate, ultramarine
- 2.3 white: lime carbonate, ultramarine
- 2.4 gray: lime carbonate, earth green
- 2.5 white mortar: lime carbonate, ultramarine
- 2.6 beige ground: lime carbonate, natural ochre, vegetal black, kaolin clay.

Chemical composition of identified pigments:

FeO + MgO + K<sub>2</sub>O + Al<sub>2</sub>O<sub>3</sub> + SiO<sub>2</sub> – earth green

Na<sub>8-10</sub>AlSi<sub>6</sub>O<sub>24</sub>S<sub>2-4</sub> – ultramarine

Al<sub>2</sub>O<sub>3</sub> + SiO<sub>2</sub> + H<sub>2</sub>O – kaolin clay

C + CaCO<sub>3</sub> + K<sub>2</sub>CO<sub>3</sub> – vegetal black

Fe<sub>2</sub>O<sub>3</sub> + H<sub>2</sub>O – hematite

Fe<sub>2</sub>O<sub>3</sub> + Al<sub>2</sub>O<sub>3</sub> + SiO<sub>2</sub> + H<sub>2</sub>O – natural ochre

CaCO<sub>3</sub> – lime carbonate.

*Translated by Iwona Zych*

Table 1. Elemental composition of samples of wall paintings determined by the SEM/EDS method in atomic percentages. Tablica 1. Skład pierwiastkowy próbek malowideł oznaczony metodą SEM/EDS w procentach atomowych.

No	C	Ca	O	Fe	Na	Al	Si	S	K	Mg
1.1A	73.51	1.60	22.49	0.20	0.17	0.33	1.02	0.32	0.21	0.15
1.2A	77.45	2.80	18.38	0.06	0.08	0.18	0.68	0.31		0.06
1.2B	75.32	1.67	22.14			0.15	0.47	0.25		
1.2C	57.59	7.63	30.06	0.45		0.58	2.28	0.40	0.60	0.39
1.3A	59.70	7.32	29.79	0.21	0.16	0.45	1.40	0.36	0.43	0.17
1.3B	59.99	6.02	31.67	0.08	0.16	0.33	0.94	0.36	0.33	0.13
1.4A	68.42	3.50	26.13	0.19	0.28	0.33	0.83	0.31		
1.5A	65.12	2.55	28.90	0.25	0.17	0.74	1.68	0.24	0.21	0.14
2.1A	45.12	3.00	45.60	0.48	0.09	1.77	3.13	0.25	0.32	0.24
2.2A	46.33	4.79	41.33	0.70		1.85	3.90	0.30	0.45	0.35
2.2B	49.80	4.36	34.59	0.87		2.58	5.50	0.29	0.90	0.67
2.3A	67.20	3.32	27.43	0.14	0.16	0.41	0.92	0.30		0.12
2.4A	68.48	4.00	24.53	0.21	0.18	0.46	1.30	0.34	0.31	0.20
2.5A	55.87	8.14	33.81		0.16	0.22	0.91	0.35	0.43	0.10
2.6A	29.96	11.14	55.75	0.44	0.69	1.94	4.54		0.69	0.85
2.6B	29.58	7.55	49.79	0.98	0.22	3.21	6.93		0.94	0.80

## Numismatic studies 2007–2009

(Piotr Jaworski)

### Introduction

The mission from the Institute of Archaeology of the University of Warsaw excavated a site of an insula at Ptolemais, situated in the city's central district, in the area of compact residential architecture with a complex configuration resulting from a long history and frequent rebuilding. A characteristic feature of the investigated insula, especially its parts adjacent to the street, is the presence of workshops and shops, which occupied the ruins of houses destroyed by the earthquake either in 262 or 365 AD. The structure of the coin series recovered during the excavation at Ptolemais reflects nicely both the past of the district under investigation and of the city at large. The coin finds from Ptolemais furnish excellent insight into the structure of the mass of coinage in circulation in one of the largest cities of Cyrenaica and, at the same time, are a valuable source for dating the investigated stratigraphic layers and architectonic structures.

### The coin finds<sup>31</sup>

The series from the Polish archaeological investigation at Ptolemais, 2002–2009, comprises approximately 1100 coins, in addition to nearly 600 pieces from the hoard of Roman coins discovered in 2006. The two largest groups are coins from the Ptolemaic period (40%) and Roman coins (48%; including as much as 66% of coins from the 4<sup>th</sup> and the 5<sup>th</sup> c. AD). A much smaller group are emissions of Roman Cyrenaica (8%), followed by Byzantine (2%) and foreign coins (2%).

The excavation seasons of 2007–2009 yielded 456 coins (151 discovered in 2007, 142 – in 2008, and 163 – in 2009). Of these perhaps the most outstanding are Roman Republican issues, rare in Cyrenaica (**Fig. 88**): three denarii

struck in the period 110–84 BC<sup>32</sup>, and an as from the 2<sup>nd</sup> c. BC,<sup>33</sup> the earliest of all the Roman coins discovered at Ptolemais. In the group of coins issued in Roman Cyrenaica a more notable specimen is a quadrans of Scato<sup>34</sup> (**Fig. 89**). There was also more evidence of the practice, common in Cyrenaica, of cutting coins struck during the 1<sup>st</sup> c. BC/ the 1<sup>st</sup> c. AD to obtain coins of smaller denominations, in short supply on the market (**Fig. 90**).<sup>35</sup> The group of cut coins from the Polish excavation at Ptolemais, now over 50, includes an outstanding halved as struck by Lollius at Knossos<sup>36</sup> (**Fig. 91**), an interesting example of the function of coinage from Crete in Roman Cyrenaica. From exploration of Hellenistic layers in the room which contained the hoard (R 56) comes a finely preserved didrachma of Magas with a portrait of Berenike I<sup>37</sup> (**Fig. 92**).

### Conservation of the hoard<sup>38</sup>

In Summer of 2007 the archaeological and conservation mission worked at Ptolemais to prevent corrosion of the coins from the hoard and make its full documentation, also, to complete exploring the rooms of the house which in Autumn of 2006 yielded this find of major importance for the archaeology of Cyrenaica. The full process of conservation was carried out, within limited time and in difficult field conditions, by Marek Kołyszko PhD (Nicolaus Copernicus University, Toruń) and Barbara Kołyszko († 2009).

The coins from the hoard were preserved for the purpose of follow-up research by cleaning their surface of accretions and making casts of their obverse and reverse. These copies, with permission of the Libyan conservation services, were shipped to Warsaw.

### The Hoard from Ptolemais – exhibition in Warsaw

This hoard was presented to the wider public at an exhibition “Skarb z Ptolemais”, opened on 15 December

<sup>31</sup> P. JAWORSKI, *Ancient coins from the Warsaw University Institute of Archaeology excavations at Ptolemais, Libya (2002-2004)*, “Archeologia” (Warsaw) LVI (2005), 2006, 77–90; idem, *Ancient coins from the Warsaw University excavations at Ptolemais (2001–2005)*, (in:) M. Luni (ed.), *Cirene...*, 213–217; idem, *Coins*, (in:) T. MIKOCCI ET AL., *Polish Archaeological Research...*, 102; idem, *Antyczne mennictwo Cyrenajki. Polskie odkrycia numizmatyczne w Ptolemais*, (in:) P. Jaworski (ed.), *Skarb z Ptolemais...*, 32–37.

<sup>32</sup> Inv. Nos.: Cn/089/07, Cn/010/08, Cn/017/08: P. JAWORSKI, *Roman Republican Coins Found in Ptolemais*, (in:) J. Żelazowski (ed.), *Ptolemais I. Essays in Honour of Tomasz Mikocki*, forthcoming.

<sup>33</sup> Inv. No. Cn/103/09.

<sup>34</sup> Inv. No. Cn/137/08.

<sup>35</sup> Inv. No. Cn/013/09.

<sup>36</sup> Inv. No. Cn/060/08.

<sup>37</sup> Inv. No. Cn/113/07.

<sup>38</sup> On the subject of the hoard and its conservation, e.g. P. JAWORSKI, *Skarb monet rzymskich z Ptolemais w Libii*, “Biuletyn numizmatyczny” 2007, No. 1 (345), 19–26; P. JAWORSKI, M. KOŁYSZKO, K. MISIEWICZ, *Skarb z Ptolemais. Rezultaty misji archeologiczno-konserwatorskiej*, Part I: ibidem, 2008, No. 1 (349), 27–38, Part II: ibidem, 2008, No. 2 (350), 95–102; P. JAWORSKI, *Skarb z Ptolemais*, (in:) P. Jaworski (ed.), *Skarb z Ptolemais...*, 40–50; M. ZAWADZKI, *Skarb z Ptolemais – znalezisko niezwykłe*, ibidem, 51–53; M. KOŁYSZKO, *Konserwacja skarbu monet rzymskich z Ptolemais*, ibidem, 56–64; P. JAWORSKI, E. WALCZAK, *Katalog*, ibidem, 104–107; P. JAWORSKI, *A hoard of Roman coins...*, 146–156; idem, *Srebrne monety rzymskie w skarbie znalezionym w Ptolemais*, “Biuletyn numizmatyczny” 2011, No. 3 (363), 161–170.

2008 in the Numismatic Cabinet of the Royal Castle in Warsaw, where, next to the plaster replicas of all the coins from the hoard, were displayed more than 80 original coins illustrating the history of coinage in Cyrenaica c. 500 BC to c. 300 AD. This was the first public presentation of the coinage of Cyrenaica in Poland. The organisers of the exhibition were fortunate to have obtained an unprecedented permission of the Libyan authorities to borrow the coins discovered during the excavation at Ptolemais, including a few silver and bronze coins from the hoard. The set of coins of ancient Cyrenaica displayed during the exhibition was complemented with pieces in the collection of the National Museum in Warsaw, including coins from a set presented to the Museum in 1921 by a famous Polish collector Władysław Semerau-Siemianowski.

### Numismatic research

The coins discovered at Ptolemais form a basis for investigating various issues related to ancient coinage and coin circulation, both in that city and in Cyrenaica at large. The source base for this research is being supplemented by a programme of recording coins from Libyan Pentapolis, found in the collections of the Tolmeita (Ptolemais) Museum as well as in public and private collections in Poland.

At the centre of research interest are questions related to the functioning of coinage in the beginning of the Roman rule in Cyrenaica,<sup>39</sup> e.g., the practice of cutting the coins,<sup>40</sup> or of countermarking coins struck in Cyrenaica under Tiberius.<sup>41</sup> One of the results of this research has been the identification of a previously unknown type of quadrans of Aulus Pupius Rufus<sup>42</sup> (Fig. 93). Currently a final publication of the coins finds from the Polish excavation at Ptolemais, 2002–2011, as well as the publication of the hoard of Roman coins are being prepared.

*Translated by Anna Kinecka*

### Geophysical surveys 2006–2009

(Krzysztof Misiewicz)

Reconstruction of the city plan with the use of non-invasive methods was the main purpose of geophysical surveys carried out in 2006–2009. Magnetic measurements

were used as the main method of surveys. Over 50 hectares were prospected with a PMP-8 proton precision magnetometer and a Bartington Grad 601-2 single axis dual sensor fluxgate gradiometer were used in the field to measure the vertical and horizontal pseudo-gradient of the magnetic field in the southern part of the town and 15 hectares in its northern part (Fig. 94). The last part of the surveyed field was also prospected with a Geometrics G858 cesium magnetometer in a detailed grid (profiles 0.5 meters apart and measurement in each 10 cm of the profile). Changes of intensity of the total magnetic field were registered with the accuracy of 0.001 nT. Additionally vertical and horizontal pseudo-gradient observations were carried out. Results of measurements presented as gray scale and colour maps of disposition of values of vertical and horizontal pseudo-gradient of the magnetic field allowed to reconstruct the complete city grid. Limits of the streets as well as remains of buildings' foundations are visible on the maps as narrow, linear anomalies in disposition of the intensity of the magnetic field. In some cases even exact plans of buried features were possible to reconstruct on the basis of the results of magnetic survey (Figs. 95, 96).

Survey of the western part of the town, close to the western defensive wall, brings a clear picture of the street grid, allowing to reconstruct not only the original Hellenistic plan of that part of Ptolemais, but also to record changes of city planning at Byzantine times.

In 2007 and 2008 also areas close to the Christian basilicas were surveyed with the purpose to gain the data for location of remains buried beneath the surface and recognition of their position inside the city grid. Data obtained with the use of mainly non-invasive methods were the basis for analysing and reconstructing the plans of buildings and reconstruction of their functions within the church complexes (see also the papers of K. Misiewicz, J. Kaniszewski and E. Wipszycka, in this volume).

Integrating data obtained with the use of all non-invasive methods (geophysics, topographical measurements, kite-aerial photography) into one system was the additional aim of our activity in 2006–2009. All maps illustrating results of geophysical and topographical surveys as well as rectified aerial photography and satellite images are located in the local coordinate system (the geodesic grid prepared

<sup>39</sup> P. JAWORSKI, *Rzymskie mennictwo Cyrenajki (I w. p.n.e.-I w. n.e.). Odkrycia misji Instytutu Archeologii UW w Ptolemais*, "Biuletyn numizmatyczny" 2006, No. 4 (344), 254–259; idem, *Cyrenaican coinage from the beginning of Roman rule. New evidence from Ptolemais*, "Światowit" VI (XLVII)/A (2004–2005), 2006, 11–18.

<sup>40</sup> P. JAWORSKI, *Rola ciętych monet brązowych w systemie monetarnym Cyrenajki w początkach Cesarstwa Rzymskiego*, (in:)

*Upięknienie – kiedy moneta staje się pieniądzem, XIV Ogólnopolska Sesja Numizmatyczna w Nowej Soli*, forthcoming.

<sup>41</sup> P. JAWORSKI, *Countermarks on the coins struck in Cyrenaica under Tiberius*, "Palamedes" 5, 2010, 167–176.

<sup>42</sup> P. JAWORSKI, *An Unknown Coin of Pupius Rufus struck in Cyrenaica*, "Wiadomości numizmatyczne" LIII/2 (188), 2009, 183–192.

for Ptolemais) and in the global coordinate (WGS84). That allowed to prepare mega data files collecting data from all used non-invasive methods and to present them in the form of ortho-photo maps (Fig. 94). All collected data will be also presented as a database in a spatial information system similar to Geographical Information System.

The analysis of the city plan, displaying all measured features visible on the ground level and firmly situated (such as aligned blocks), connected both to the satellite image and the contour map and supplemented by information gathered from geophysical survey, has been used to prepare a virtual reconstruction of the Hellenistic-Roman city grid and the layout of the insulae.<sup>43</sup>

Results of surveys should form the basis for methodology of detecting deep buried structures covered with the earth coming from earlier excavations deposited in the northern part of the site as well as for planning activity in the insula excavated by the Polish archaeological mission.

Mgr Miron Bogacki  
Institute of Archaeology  
University of Warsaw  
norim@epf.pl

Dr Krzysztof Chmielewski  
Academy of Fine Arts in Warsaw  
chmiel@asp.waw.pl

Mgr Piotr Jaworski  
IA UW  
stefan.benito@wp.pl

Mgr Zofia Kowarska  
Faculty of History  
University of Warsaw  
cofijka@op.pl

Mgr Szymon Lenarczyk  
Faculty of History  
University of Warsaw  
lenon8@op.pl

Dr hab. prof. UW Kazimierz Lewartowski  
IA UW  
k.lewartowski@uw.edu.pl

Mgr Wiesław Małkowski  
IA UW  
wmalkowski@uw.edu.pl

Dr hab. Krzysztof Misiewicz  
IA UW  
geomis@iaeapan.edu.pl

Mgr Zbigniew Polak  
IA UW  
pabt.iau@uw.edu.pl

Dr Monika Rekowski-Ruszkowska  
IA UW  
mrekowska@uw.edu.pl

Mgr Elżbieta Rosłonec  
National Museum in Warsaw  
erosloniec@mnw.art.pl

Dr George Yacoub  
IA UW  
gyacoub@uw.edu.pl

Dr Jerzy Żelazowski  
IA UW  
j.zelazowski@uw.edu.pl

JERZY ŻELAZOWSKI, MONIKA REKOWSKA-RUSZKOWSKA, ZOFIA KOWARSKA, SZYMON LENARCZYK, KRZYSZTOF CHMIELEWSKI, ELŻBIETA ROŚLONIEC, PIOTR JAWORSKI, KRZYSZTOF MISIEWICZ, KAZIMIERZ LEWARTOWSKI, GEORGE YACOUB, MIRON BOGACKI, WIESŁAW MAŁKOWSKI, ZBIGNIEW POLAK

#### POLSKIE BADANIA ARCHEOLOGICZNE W PTOLEMAIS (LIBIA) 2007–2009. RAPORT WSTĘPNY

W latach 2007–2009 kontynuowano – rozpoczęte w 2001 przez prof. Tomasza Mikockiego – prace wykopaliskowe na terenie tzw. Willi z Widokiem, obejmującej kompleks kilku domów, a także rozwijano projekt badań nad topografią miasta antycznego przy użyciu metod geofizycznych, prospekcji terenowej i fotografii latawcowej.

jęcej kompleks kilku domów, a także rozwijano projekt badań nad topografią miasta antycznego przy użyciu metod geofizycznych, prospekcji terenowej i fotografii latawcowej.

<sup>43</sup> K. MISIEWICZ, W. MAŁKOWSKI, M. MUSZYŃSKA, *The Topography of Ptolemais. Preliminary results of geophysical surveys*,

“Archeologia” (Warsaw) LIX (2008), 2010, 73–80.

Prowadzono też prace konserwatorskie nad zabezpieczeniem odkrytych mozaik i malowideł ściennych.

Eksploatacja archeologiczna miała na celu odsłonięcie możliwie największych partii domów odkrytych już wcześniej. Badano więc kompleks pomieszczeń leżących na północny wschód od płytowanego atrium; odsłonięto też całe wschodnie skrzydło Domu Leukaktiosa; rozpoznano pomieszczenia leżące wzdłuż ulicy zachodniej, należące do domu z mozaiką geometryczną; próbowano też odpowiedzieć na pytanie o charakter późnoantycznego pomieszczenia z absydą.

Cechą charakterystyczną niemal całego badanego obszaru jest jego intensywne użytkowanie w celach wytwórczych i magazynowych w okresie po zniszczeniach w III i IV w. Zazwyczaj działalność ta wykorzystywała stare posiadki, toteż akumulowały się na nich warstwy użytkowe. Zaobserwowano ślady produkcji wina, której służyło siedem, odkrytych w różnych pomieszczeniach, podziemnych zbiorników wykonanych z zaprawy hydraulicznej, rozmieszczonych wyraźnie w dwóch rejonach: V 1–3 w R 46 i R 75, oraz V 4–7 w R 52 i R 59. Zbiornikom drugiej grupy towarzyszyła posadzka z zaprawy, położona na wcześniejszej, i ukształtowana w sposób uniemożliwiający spływanie cieczy do wnętrza. Natomiast nie ma takiej posadzki przy zbiornikach pierwszej grupy. W ich przypadku wylewy zostały otoczone zaprawą hydrauliczną lub niewielkim płytowaniem kamiennym. Głębokość zbiorników jest różna, waha się od ok. 2 m (grupa pierwsza) do ponad 3 m (grupa druga). Wszystkie zbiorniki mają elementy pozwalające na przykrycie ich pokrywami lub płytami kamiennymi. W ich wnętrzach, na różnej głębokości, występuje niewielkie przewężenie, służące zapewne osadzeniu na jego brzegu jakiejś instalacji, np. sit. Prawdopodobnie również z produkcją wina miała związek platforma w R 73, o bardzo gładkiej powierzchni, wykonana z zaprawy hydraulicznej.

Pozostałością drugiego rodzaju aktywności produkcyjnej są piece różnego przeznaczenia. Największy z nich – K 3 – w pomieszczeniu R 70 miał dwuczęściową komorę i dwie fazy użytkowania, jednak nie dało się ustalić jego przeznaczenia. Wiadomo natomiast, że mały piec w R 73 służył do wypalania wapna, natomiast piec w R 45 – do wypalania ceramiki. Zapewne potrzebom tego samego garncarza służyła też glina składowana w pobliskim zbiorniku V 1, w którym znaleziono też niewypalone naczynia z niej wykonane.

Na całym badanym obszarze występuje szereg poziomów zniszczeń, zawierających fragmenty ceramiki środkowo- i późnorzymskiej, lamp, szkła, tynków i malowideł ściennych, przedmiotów metalowych, tessery i monety. W niektórych częściach, głównie w zachodniej, w niższych poziomach widoczny był popiół i węgle drzewne. Główny składnik warstw zniszczenia stanowiła glina wraz z drobnymi fragmentami ceramiki i kamykami, pochodząca z konstrukcji ścian, które w wyższych partiach były zrobione z cegły suszonej.

Ukończono badania we wschodniej części Domu Leukaktiosa, który sięgał do samej ulicy, zajmując całą szerokość insuli. Jego szerokość, 36,61 m, wyznaczają: mur W 1 od zachodu i nowo odkryty W 157, biegnący wzdłuż ulicy wschodniej. Poniżej W 157 leży zbudowany z dużych bloków mur W 164, datowany na okres hellenistyczny. Wraz z W 1 od zachodu wyznacza on pierwotną szerokość insuli okresu ptolemejskiego (36 m).

Większą część wschodniego skrzydła zajmuje duży dziedziniec R 46, oddzielony od ulicy serią pomieszczeń, częściowo płytowanych, trudnych do rozpoznania ze względu na zły stan zachowania. Prowadziły z nich na dziedziniec przejścia, z których największe i niewątpliwie główne wyznacza duży próg na wysokości płytowania R 77. Z Domem Leukaktiosa dziedziniec połączony był również szerokim wejściem poprzez pomieszczenie R 5.

Dziedziniec był wyłożony zaprawą, tworzącą dwie warstwy. W wyższej znajdował się odcisk kolumny, należącej do wyposażenia drugiej fazy użytkowania dziedzińca, kiedy to bazy, kapitele i trzony służyły jako stoły i siedziska. Pod posadzką znaleziono fragmenty murów W 49 i W 165 należących do wcześniejszej fazy użytkowania. Posadzka mozaikowa pomieszczenia R 45, graniczącego od południa z dziedzińcem, położona na niższym od niego poziomie, też mogła należeć do tej wcześniejszej, słabo rozpoznawalnej fazy.

Granicę Domu Leukaktiosa od północy wyznacza mur W 168 (= W 114). Pomiędzy nim a dziedzińcem znajduje się jeszcze mur W 167, również z progiem ze śladami długotrwałego lub intensywnego użytkowania. Pierwotne pomieszczenie, jakie tworzyły te mury, zostało podzielone przez wybudowany później W 171 na dwa osobne (R 80, R 81). Od ulicy wschodniej R 81 oddzielało bardzo zniszczone pomieszczenie z fragmentem zachowanego *opus signinum*. Przejście między R 80 i R 81 było wyposażone w profilowane ościeżnice, a jego szerokość sugeruje, że było ono przykryte łukiem. W tym rejonie znajdowało się też wiele fragmentów malowideł ściennych oraz zaprawy przygotowanej pod malowidła. Znaleziono też kamienną bazę, być może pod posąg, co wraz z wystrojem architektonicznym wskazuje na istotne znaczenie pomieszczeń R 80 i R 81, które nie były połączone bezpośrednio z wnętrzem Domu Leukaktiosa.

Dom z Atrium znajduje się na poziomie nieco wyższym niż Dom Leukaktiosa, jednak tworzył z nim pierwotnie jedną całość, o czym świadczy zamurowane przejście w murze W 14. Dokładne badania atrium (R 51) wykazały, że płytowanie dookoła impluvium jest nachylone w taki sposób, by woda opadowa ściekała do basenu, co sugeruje, że mimo znalezienia tam baz kolumn, było to pierwotnie pomieszczenie nie zadaszone. Wydaje się więc prawdopodobne, że pomieszczenie R 54, leżące w głębi i nieco wychodzące poza szerokość atrium, mogło stanowić rodzaj portyku. Nadmiar wody odprowadzano dwoma kanałami, jednym do ulicy zachodniej, a drugim do cysterny C 1.

Na południe od atrium znajduje się pomieszczenie R 48, połączone z nim szerokim wejściem o profilowanych ościeżnicach oraz ze śladami malowideł ściennych po obu jego stronach, co wskazuje na oficjalną funkcję tego pokoju. Poniżej jego posadzki znajduje się fragment muru W 130 należącego do najwcześniejszej w tym rejonie Ptolemais, hellenistycznej zabudowy. Do kompleksu atrium zaliczają się także pomieszczenia R 52 z fragmentami malowideł ściennych i R 59 tworzące jego wschodnie skrzydło.

Na północny wschód od atrium odsłonięto duży, płytowany dziedziniec R 68 z impluvium. Wraz z pomieszczeniami R 70, R 71, R 72, R 73 i R 83 tworzy on kolejny dom, niezbadany jeszcze w jego wschodniej części. Taki układ jest wynikiem kolejnych zmian, jakie musiały tu następować, i podziałów zabudowy na mniejsze domy. Świadectwem takich zmian jest np. blok w płytowaniu dziedzińca ukształtowany tak, by odprowadzać z niego nadmiar wody do pomieszczenia R 32, które należało do Domu Leukaktiosa. W sąsiadującym z dziedzińcem od zachodu pomieszczeniu R 70 znaleziono fragmentarycznie zachowaną posadzkę mozaikową i ślady przebudowy w późnym okresie użytkowania tej części domu.

Całkowite odsłonięcie Domu z Atrium pozwoliło na przestudiowanie dekoracji malarskiej tego niewielkiego zespołu. Jej pozostałości, zachowane w dolnej części, odkryto w trzech pomieszczeniach południowej partii domu: R 50, R 48, R 52. Nigdzie nie znaleziono śladów kompozycji figuralnych – występuje tu tylko dekoracja w formie pasów i oddzielonych liniami paneli oraz malarskiej imitacji różnych rodzajów marmuru. Podobne malowidła znane są z Domu Leukaktiosa i wielu innych domów Cyrenajki.

Prace o niewielkim zakresie prowadzono też wzdłuż zachodniej ulicy (R 74, R 79, R 76). Uchwycono północną, bardzo zniszczoną, kontynuację głównego muru W 1 ograniczającego zabudowę insuli od strony zachodniej. Duży blok, tworzący próg, może wskazywać na istnienie wejścia z ulicy do pomieszczenia R 74. Wszystkie trzy pomieszczenia wykazują intensywne ślady użytkowania po okresie zamieszkania domu.

Podjęto próbę zbadania pomieszczenia z absydą R 65. Ze względu na znaczną koncentrację gruzu kamiennego w jego wnętrzu nie zdołano osiągnąć posadzki. W wypełniku znaleziono fragment późnoantycznego architravu oraz kolumny o spiralnym żłobkowaniu, a także bardzo niewiele fragmentów ceramicznych, marmurowych i odłamków cegieł. Wyjaśnienie więc, czy mamy do czynienia z budowlą kościelną, czy też z reprezentacyjną salą rezydencji późno antycznej, trzeba odłożyć na później, do czasu ukończenia prac.

Przeprowadzono też intensywne prace konserwatorskie. Szczególną uwagę poświęcono ocalałym partiom malowideł ściennych. Wszystkie dobrze zachowane (ok. 80%), zostały zdjęte ze ścian i zdeponowane w Muzeum Tolmeity (Ptolemais). Ta procedura została poprzedzona drobiazgową dokumentacją rysunkową i fotograficzną. Powierzchnie malowideł oczyszczono i – w osłabionych partiach – wzmocniono żywicą syntetyczną. Następnie zabezpieczono je za pomocą warstw bibułki japońskiej, gazy bawełnianej i tkaniny bawełnianej. Malowidła odcięto od ścian za pomocą pił, noży, długich dłut i umieszczono powierzchnią malowaną w dół na paletach drewnianych, pokrytych gąbką. Natomiast malowidła pozostałe na ścianach ujęto w opaski z zaprawy, oczyszczono, wzmocniono ich powierzchnie za pomocą żywicy syntetycznej, a następnie przykryto oddychającą folią i częściowo przysypano przesianą ziemią z wykopów, by ochronić je przed zniszczeniem z przyczyn naturalnych lub antropogennych.

W omawianym okresie odkryto 456 monet. Na szczególną uwagę zasługują cztery okazy republikańskie (trzy denary z lat 110–84 p.n.e. i as z II w. p.n.e.), najwcześniejsze rzymskie monety kiedykolwiek znalezione w Ptolemais. Odkryto też wiele kolejnych świadectw praktyki cięcia monet w obliczu dużego deficytu pieniądza w okresie I w. p.n.e. – I w. n.e. Skarb monet rzymskich znaleziony w 2006 roku został poddany gruntownej konserwacji, a w grudniu 2008 otwarto na Zamku Królewskim w Warszawie poświęconą mu wystawę.

Istotnym elementem studium topografii miasta antycznego były prace metodami geofizycznymi. Przebadano w ten sposób łącznie 50 hektarów zachodniej i centralnej części miasta. Do pomiarów używano magnetometru protonowego, gradiometru Bartington Grad 601-2 oraz magnetometru cezowego. Rozpoznano wiele struktur znajdujących się pod powierzchnią, zrekonstruowano oryginalną, hellenistyczną siatkę ulic i jej zmiany w okresie bizantyńskim. Połączenie metod geofizycznych z fotografią latawcową i satelitarną oraz pomiarami geodezyjnymi pozwala dobrze dokumentować widoczne i niewidoczne konstrukcje w postaci ortofotomap oraz tworzyć bazę danych w systemie informacji przestrzennej (GIS).

Najbliższe plany, o ile okoliczności na to pozwolą, obejmują dokończenie badania wschodniej części domu z płytowanym dziedzińcem, co pozwoli na uzyskanie całościowego obrazu trzech domów. Dokończenia wymaga też program badań geofizycznych na terenie miasta antycznego, dzięki czemu powstanie mapa całego, dostępnego badaniom obszaru. Należy też przygotować do ekspozycji malowidła przeniesione do muzeum, o ile zostanie wygospodarowana odpowiednia powierzchnia dla takiej wystawy.



Fig. 1. Central part of the House of Leukaktios (Photo M. Bogacki).

Ryc. 1. Centralna część Domu Leukaktiosa.



Fig. 2. Aerial view of the excavated area in 2008 (Photo M. Bogacki).

Ryc. 2. Widok z latawca na obszar wykopaliisk przebadany w 2008 roku.



PLATE 2



Fig. 3. Plan of the excavated area in 2007–2010 (by W. Małkowski, J. Żelazowski).

Ryc. 3. Plan obszaru badanego w latach 2007–2010.

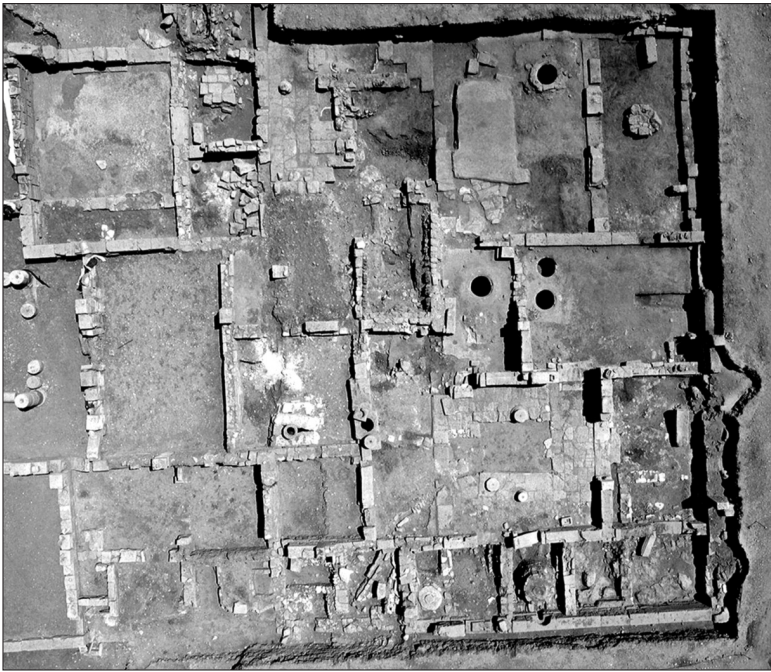

Fig. 4. Aerial view of the southern part of the excavated area in 2008 (Photo M. Bogacki).

Ryc. 4. Widok z latawca na południową część obszaru przebadanego w 2008 roku.



Fig. 5. Blocking in the south wall (W 14) of Room R 1 (Photo Polish Archaeological Mission to Ptolemais).

Ryc. 5. Blokaż w południowym murze W 14 pomieszczenia R 1.



Fig. 6. Entrance from the western street to the House of the Atrium (R 44) (Photo Polish Archaeological Mission to Ptolemais).

Ryc. 6. Wejście do Domu z Atrium od strony ulicy zachodniej (R 44).

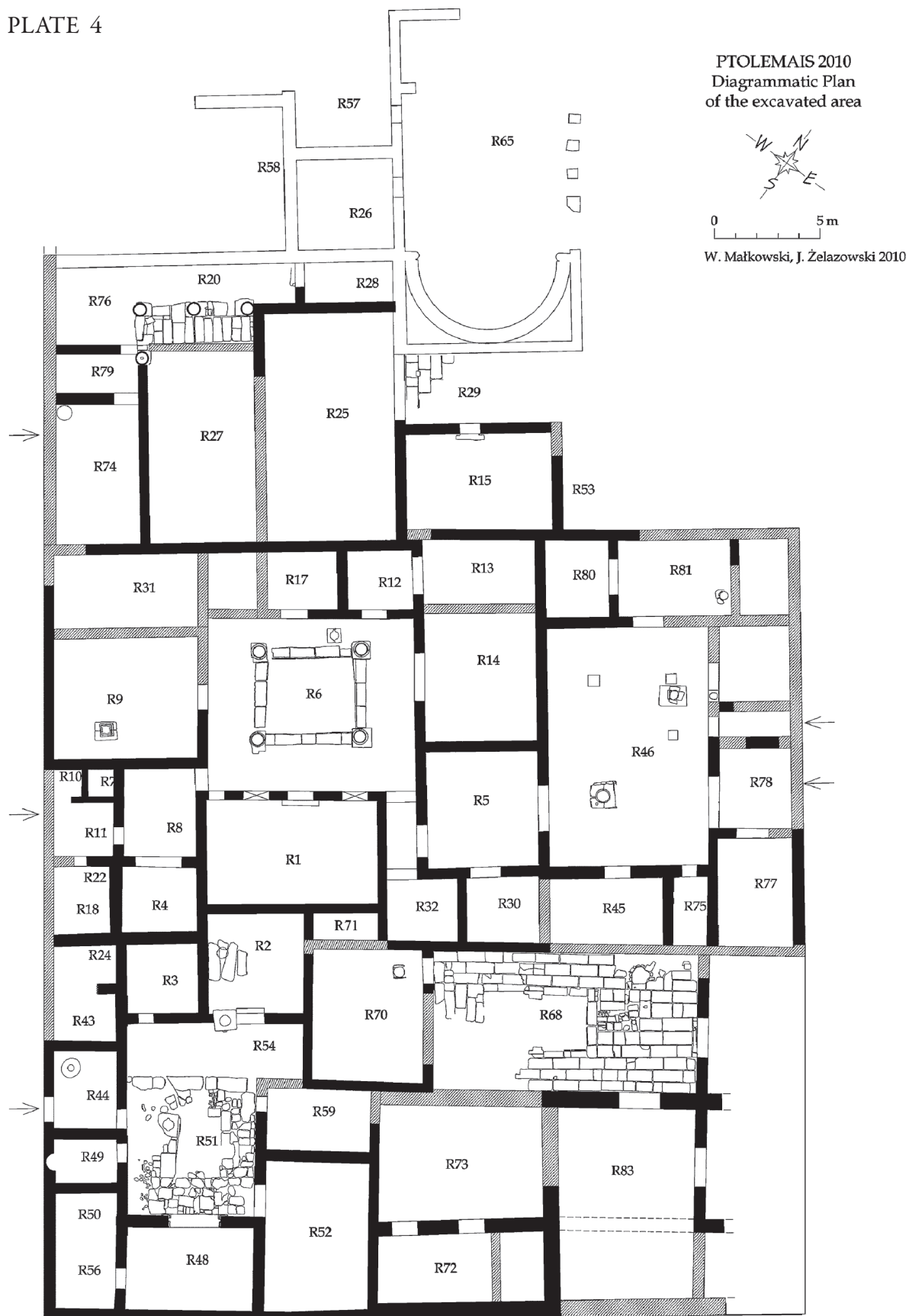

Fig. 7. Diagrammatic plan of the area excavated by Polish Archaeological Mission to Ptolemais (by W. Małkowski, J. Żelazowski).

Ryc. 7. Schematyczny plan obszaru zbadanego przez Polską Misję Archeologiczną w Ptolemais.

Fig. 8. Room R 59 with two circular vats (Photo Polish Archaeological Mission to Ptolemais).

Ryc. 8. Pomieszczenie R 59 z widocznymi dwoma okrągłymi zbiornikami.



Fig. 9. Room R 59 with a view for Wall W 105 (Photo Polish Archaeological Mission to Ptolemais).

Ryc. 9. Widok na mur W 105 w pomieszczeniu R 59.

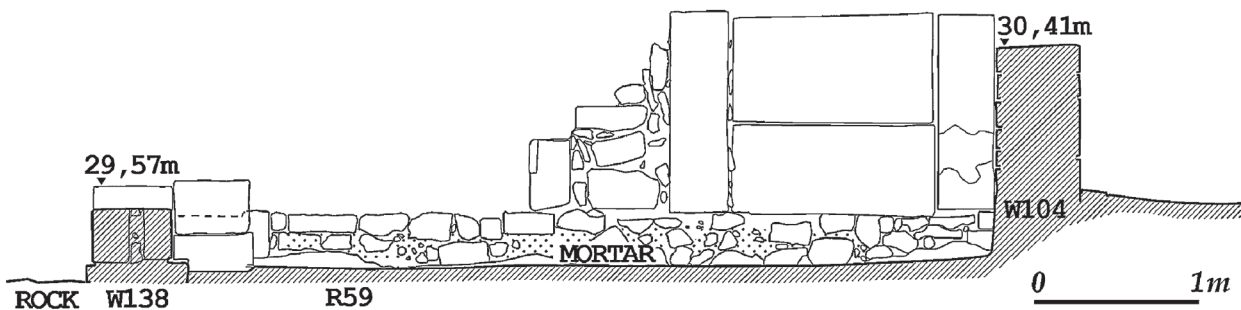

Fig. 10. NW face of Wall W 105 in R 59 (drawn by Z. Polak, elaborated by M. Różycka).

Ryc. 10. NW lico muru W 105 w pomieszczeniu R 59.

PLATE 6

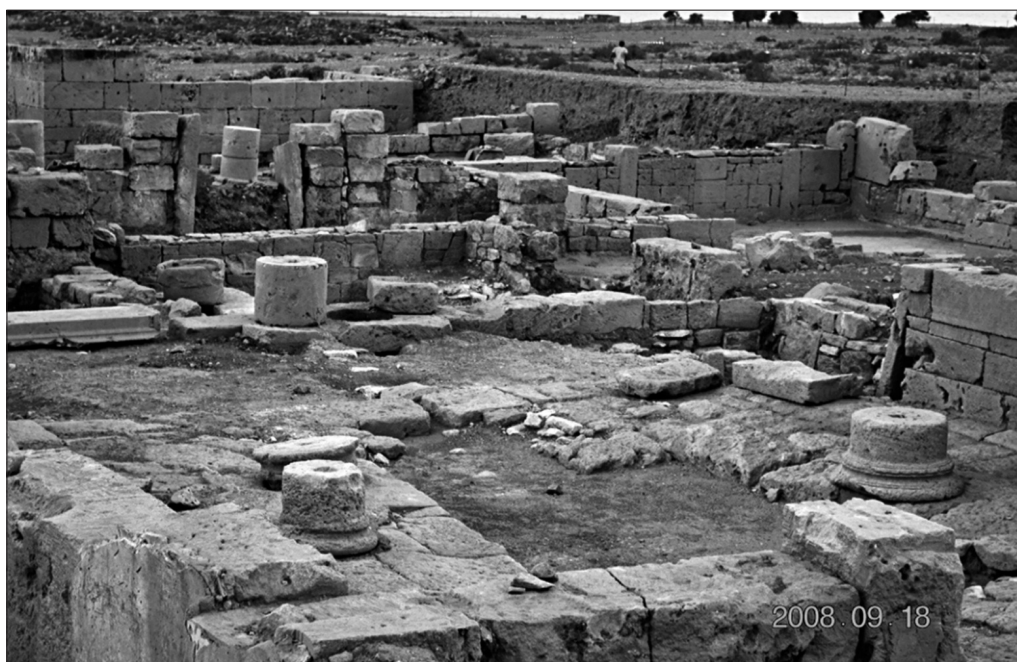

Fig. 11. View of the courtyard R 51 from the SW corner (Photo Polish Archaeological Mission to Ptolemais).

Ryc. 11. Widok od strony południowo-zachodniej na dziedziniec R 51.

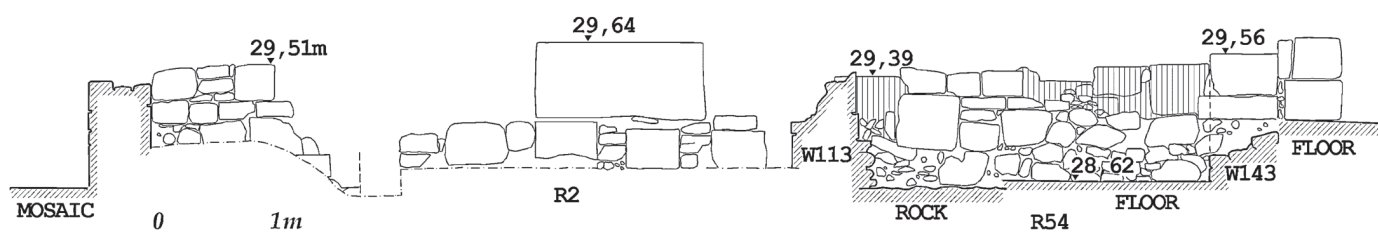

Fig. 12. SW face of Walls W 144 and W 139 in Rooms R 2 and R 54 (drawn by Z. Polak, elaborated by M. Różycka).

Ryc. 12. SW lica murów W 144 i W 139 w pomieszczeniach R 2 i R 54.



Fig. 13. Walls W 101 and W 102 with the entrance to Room R 48 from the courtyard R 51 (Photo Polish Archaeological Mission to Ptolemais).

Ryc. 13. Mury W 101 i W 102 z wejściem do pomieszczenia R 48, widok od strony dziedzińca R 51.

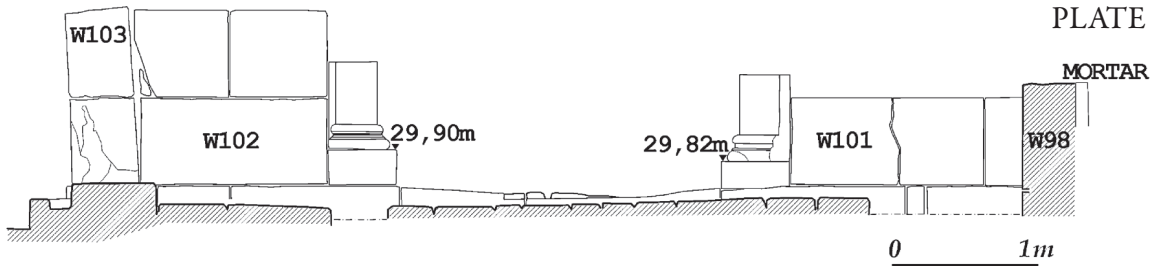

Fig. 14. NW face of Walls W 101 and W 102 in Room R 51 (drawn by Z. Polak, elaborated by M. Różycka).

Ryc. 14. NW lica murów W 101 i W 102 w pomieszczeniu R 51.



Fig. 15. Stone channels in Room R 43 (Photo Polish Archaeological Mission to Ptolemais).

Ryc. 15. Kamienne dreny w pomieszczeniu R 43.

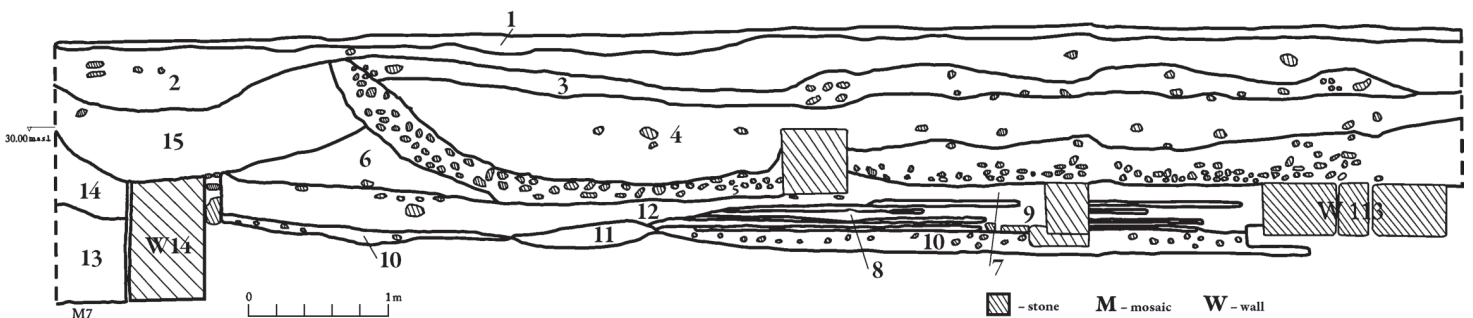

Fig. 16. N-S section of R 2 (drawn in 2002 by J. Żelazowski, elaborated by Z. Kowarska, S. Lenarczyk). Layers: 1. grey hardened soil; 2. grey hardened soil mixed with reddish brown soil mixed with fragments of mortar; 3. loose grey soil mixed with stones and white mortar; 4. loose grey soil mixed with reddish brown clay, stones and fragments of white mortar; 5. loose grey soil mixed with stones and fragments of white mortar; 6. grey soil mixed with reddish clay, stones and fragments of white mortar; 7. hardened reddish soil mixed with fragments of white mortar; 8. bluish soil; 9. hardened reddish soil; 10. reddish soil mixed with clay, stones and fragments of white mortar; 11. stone; 12. soil mixed with ash; 13. brown soil mixed with fragments of stucco and mortar; 14 brown, hardened soil mixed with fragments of stucco and mortar; 15. hardened reddish clay mixed with many very small fragments of mortar.

Ryc. 16. Przekrój N-S przez pomieszczenie R 2. Warstwy: 1. szara zbita ziemia; 2. szara zbita ziemia przemieszana z fragmentami zaprawy; 3. sypka szara ziemia przemieszana z kamieniami i fragmentami białej zaprawy; 4. sypka szara ziemia przemieszana z czerwawobrązową gliną, kamieniami i fragmentami białej zaprawy; 5. sypka szara ziemia przemieszana z kamieniami i fragmentami białej zaprawy; 6. szara ziemia przemieszana z czerwawą gliną, kamieniami i fragmentami białej zaprawy; 7. zbita czerwawą ziemia przemieszana z fragmentami białej zaprawy; 8. ziemia o zabarwieniu szaroniebieskawym; 9. zbita czerwawą ziemia; 10. czerwawą ziemia przemieszana z gliną, kamieniami i fragmentami białej zaprawy; 11. kamień; 12. ziemia przemieszana z popiołem; 13. brązowa ziemia przemieszana z fragmentami tynków i zaprawy; 14. brązowa, zbita ziemia przemieszana z fragmentami tynków i zaprawy; 15. zbita czerwawą ziemia przemieszana z dużą ilością drobnych fragmentów zaprawy.

PLATE 8



Fig. 17. View for Rooms R 30 and R 32 delimited to the south by Wall W 75 (Photo Polish Archaeological Mission to Ptolemais).

Ryc. 17. Widok na pomieszczenia R 30 i R 32 ograniczone od strony południowej murem W 75.

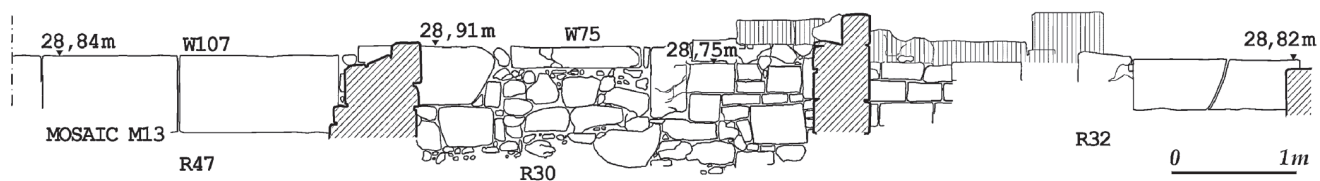

Fig. 18. NW face of Walls W 75 and W 107 in Rooms R 45, R 30, R 32 (drawn by Z. Polak, elaborated by M. Różycka).

Ryc. 18. NW lica murów W 75 i W 107 w pomieszczeniach R 45, R 30, R 32.



Fig. 19. Room R 30 (Photo Polish Archaeological Mission to Ptolemais).

Ryc. 19. Pomieszczenie R 30.

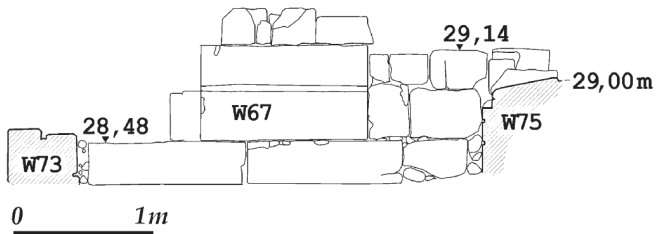

Fig. 20. NE face of Wall W 67 in Room R 30 (drawn by Z. Polak, elaborated by M. Różycka).

Ryc. 20. NE lico muru W 67 w pomieszczeniu R 30.

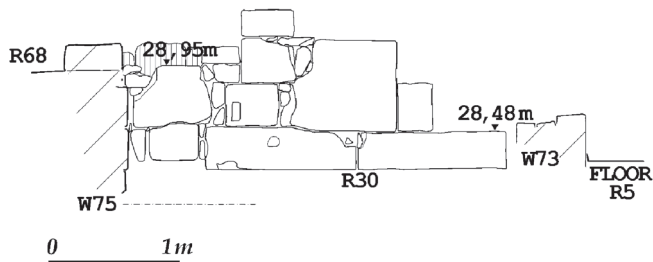

Fig. 21. SW face of Wall W 67 in Room R 32 (drawn by Z. Polak, elaborated by M. Różycka).

Ryc. 21. SW lico muru W 67 w pomieszczeniu R 32.

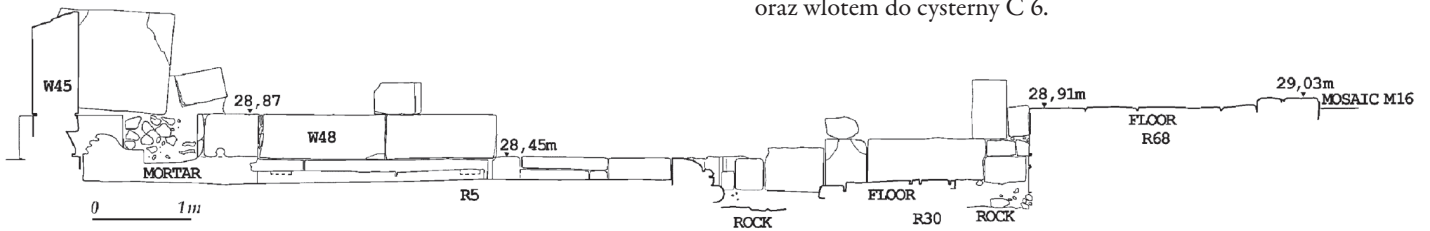

Fig. 22. SW face of Wall W 48 in Rooms R 5 and R 30 (drawn by Z. Polak, elaborated by M. Różycka).

Ryc. 22. SW lico muru W 48 w pomieszczeniach R 5 i R 30.

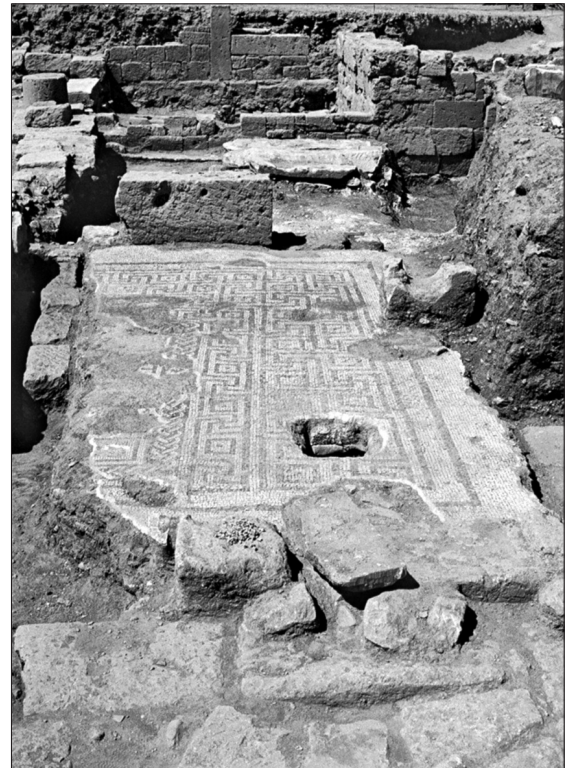

Fig. 23. Room R 70 with the mosaic floor (M 15) and the cistern mouth (C 6) (Photo Polish Archaeological Mission to Ptolemais).

Ryc. 23. Pomieszczenie R 70 z widoczną mozaiką M 15 oraz wlotem do cysterny C 6.

Fig. 24. Room R 70 with the broken mosaic and Wall W 142 (Photo Polish Archaeological Mission to Ptolemais).

Ryc. 24. Pomieszczenie R 70 z widoczną zniszczoną mozaiką oraz murem W 142.





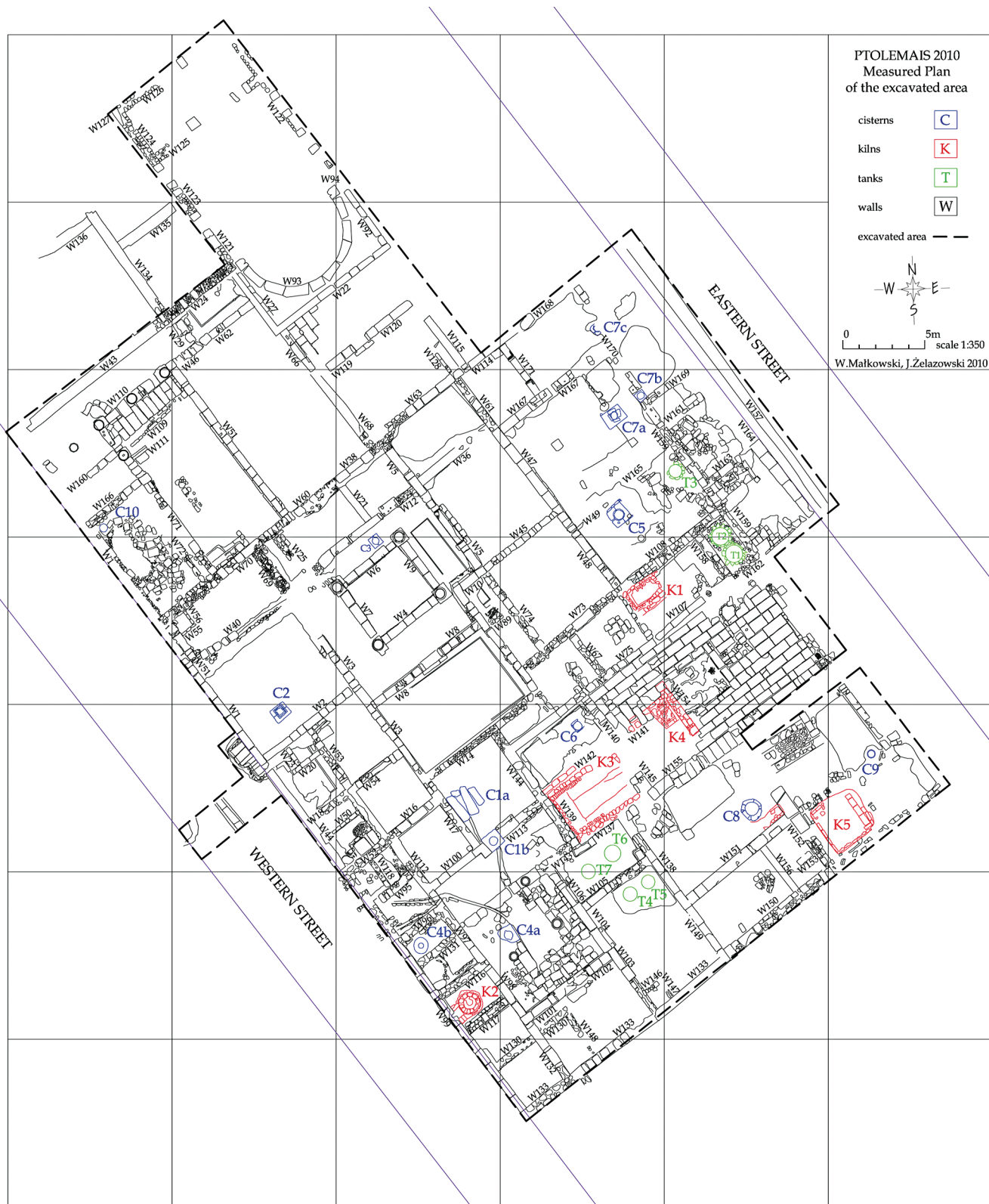

Fig. 25. Measured plan of the excavated area (W. Małkowski, J. Żelazowski).

Ryc. 25. Plan badanego obszaru.

Fig. 26. Kiln (K 3) during the exploration (Unit 13/07) (Photo Polish Archaeological Mission to Ptolemais).

Ryc. 26. Piec K 3 podczas eksploracji (jednostka stratygraficzna 13/07).



Fig. 27. Kiln (K 3) after the exploration (Photo Polish Archaeological Mission to Ptolemais).

Ryc. 27. Piec K 3 po zakończeniu eksploracji.



Fig. 28. SE face of Walls W 101 and W 102 in Room R 48 (drawn by Z. Polak, elaborated by M. Różycka).

Ryc. 28. SE lica murów W 101 i W 102 w pomieszczeniu R 48.

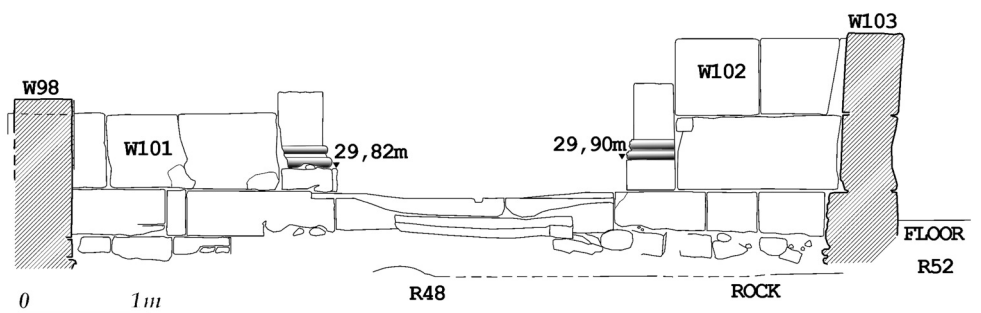

PLATE 12



Fig. 29. Room R 50 with the entrance to Room R 48 and Wall W 130 (Photo Polish Archaeological Mission to Ptolemais).

Ryc. 29. Pomieszczenie R 50 z wejściem do pomieszczenia R 48 i murem W 130.

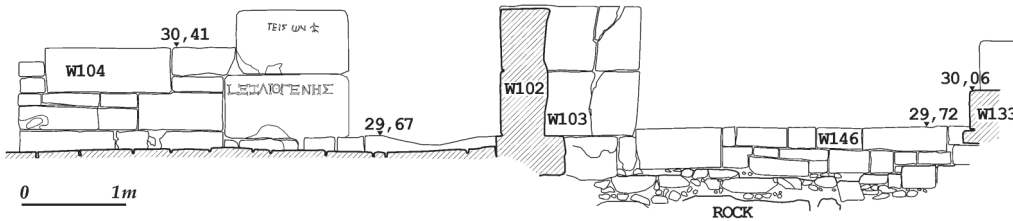

Fig. 30. SW face of Walls W 104, W 103 and W 146 in Rooms R 51 and R 48 (drawn by Z. Polak, elaborated by M. Różycka).

Ryc. 30. SW lica murów W 104, W 103 i W 146 w pomieszczeniach R 51 i R 48.

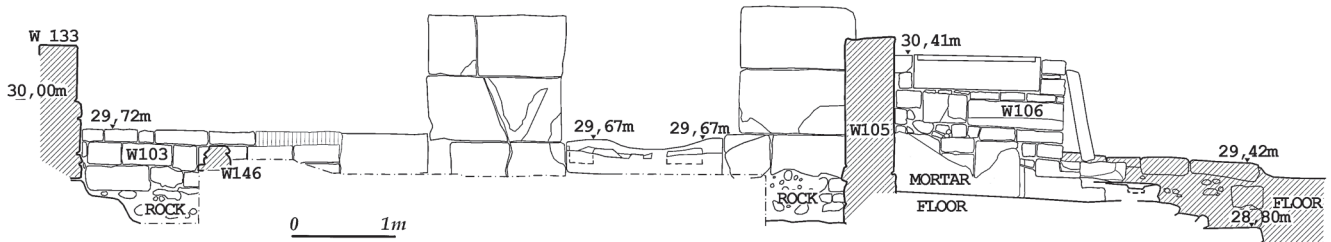

Fig. 31. NE face of Walls W 103, W 104, and W 106 in Rooms R 52 and R 59 (drawn by Z. Polak, elaborated by M. Różycka).

Ryc. 31. NE lica murów W 103, W 104, W 106 w pomieszczeniach R 52 i R 59.

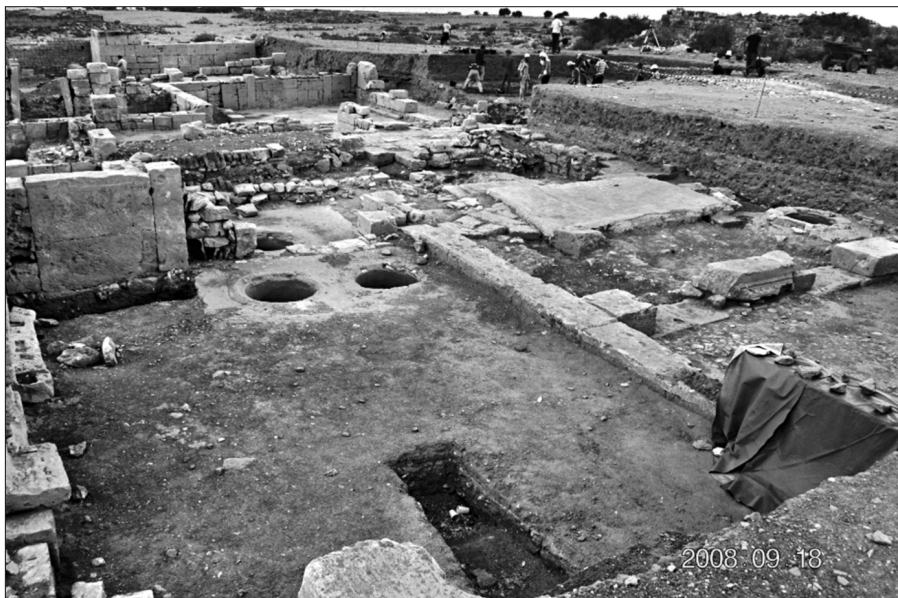

Fig. 32. Room R 52 (Photo Polish Archaeological Mission to Ptolemais).

Ryc. 32. Pomieszczenie R 52.

Fig. 33. Door lintel found next to Wall W 149 (Unit 5/08) (Photo Polish Archaeological Mission to Ptolemais).

Ryc. 33. Nadproże znalezione obok muru W 149 (jednostka stratygraficzna 5/08).



Fig. 34. Storage vats in Room R 52 (Photo Polish Archaeological Mission to Ptolemais).

Ryc. 34. Zbiorniki w posadzce pomieszczenia R 52.



Fig. 35. Room R 72 (Photo Polish Archaeological Mission to Ptolemais).

Ryc. 35. Pomieszczenie R 72.

PLATE 14

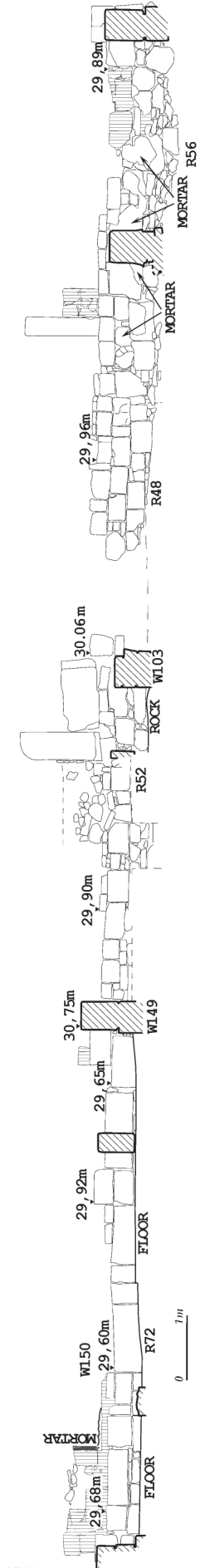

Fig. 36. NW face of Walls W 133 and W 150 in Rooms R 56, R 48, R 52 and R 72 (drawn by Z. Polak, elaborated by M. Różycka).

Ryc. 36. NW lica murów W 133 i W 150 w pomieszczeniach R 56, R 48, R 52 i R 72.

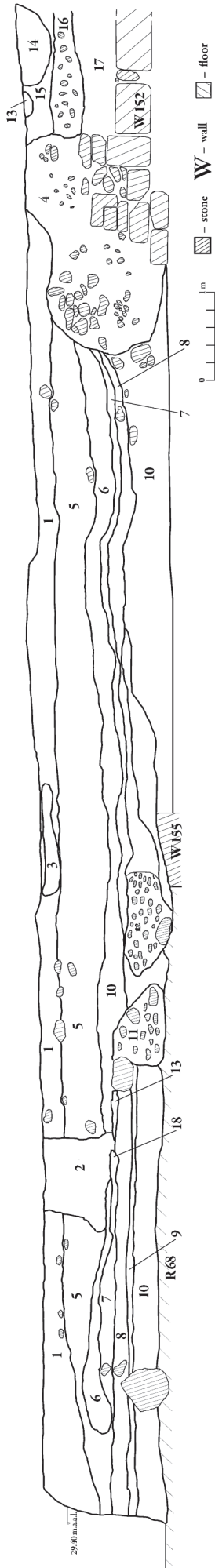

Fig. 43. Section NW-SE of the area excavated in 2010 (drawn by J. Balcerzak, A. Klimek, K. Żebrowska, elaborated by Z. Kowarska, S. Lenarczyk). Layers: 1. pale brown loose soil mixed with small stones (Unit 1/10); 2. dark yellowish brown hardened soil mixed with small stones; 3. dark brown hardened soil; 4. hardened soil, mixed with huge stones; 5. yellowish brown soil (Unit 10/10); 6. brownish yellow hardened soil mixed with small stones; 7. dark grey hardened soil mixed with small stones; 8. very pale brown hardened soil (Unit 30/10); 9. pale brown loose soil mixed with a small amount of small stones (Unit 33/10); 10. yellowish brown hardened soil mixed with small stones (Units 38/10 and 40/10); 11. dark yellowish brown hardened soil mixed with stones; 12. dark reddish brown hardened soil; 13. dark yellowish brown loose soil; 14. light grey mortar mixed with stones; 15. dark loose soil; 16. pale brown loose soil mixed with big amount of stones and fragments of pottery; 17. yellowish soil mixed with small stones; 18. occupation level/floor (Unit 29/10).

Ryc. 43. Profil NW-SE obszaru eksplorowanego w 2010 roku (rys. J. Balcerzak, A. Klimek, K. Żebrowska, oprac. Z. Kowarska, S. Lenarczyk). Warstwy: 1. jasnoszara sypka ziemia przemieszana z małymi kamieniami (jedn. stratygraficzna 1/10); 2. ciemna żółtobrązowa zbita ziemia przemieszana z małymi kamieniami; 3. ciemnobrązowa zbita ziemia; 4. zbita ziemia przemieszana z dużymi kamieniami; 5. żółtobrązowa zbita ziemia przemieszana z małymi kamieniami; 6. jasnobrązowa zbita ziemia przemieszana z małą ilością niewielkich kamieni (jedn. stratygraficzna 30/10); 7. jasnobrązowa zbita ziemia (jedn. stratygraficzna 10/10); 8. żółtobrązowa zbita ziemia przemieszana z małymi kamieniami; 9. jasnobrązowa sypka ziemia przemieszana z małą ilością niewielkich kamieni (jedn. stratygraficzna 30/10); 10. żółtobrązowa zbita ziemia przemieszana z małymi kamieniami; 11. ciemna żółtobrązowa zbita ziemia przemieszana z kamieniami; 12. ciemna żółtobrązowa sypka ziemia; 13. ciemnoczerwono-brązowa warstwa zbitej ziemi; 14. jasnoszare fragmenty zaprawy przemieszane z małymi kamieniami; 15. ciemnoszara sypka ziemia; 16. jasnobrązowa sypka ziemia przemieszana z małymi kamieniami; 17. żółtawa ziemia przemieszana z małymi kamieniami; 18. poziom użytkowy/podłoga (jedn. stratygraficzna 29/10).

Fig. 37. Room R 72 with a round structure and architectural element (Photo Polish Archaeological Mission to Ptolemais).

Ryc. 37. Pomieszczenie R 72 z kolistą strukturą i fragmentami architektonicznymi.



Fig. 38. Room R 73 with fragments of mosaic floor and stone pavement (Photo Polish Archaeological Mission to Ptolemais).

Ryc. 38. Pomieszczenie R 73 z fragmentami mozaiki i kamiennego płytowania.



Fig. 39. Room R 73 with a rectangular platform of waterproof mortar (Photo Polish Archaeological Mission to Ptolemais).

Ryc. 39. Pomieszczenie R 73 z prostokątną platformą z zaprawy hydraulicznej.



PLATE 16

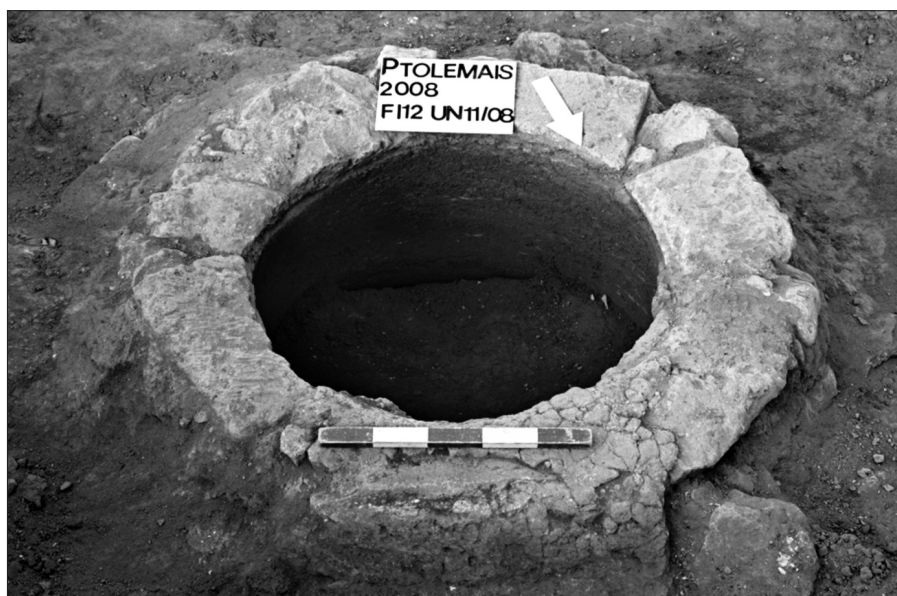

Fig. 40. Mouth of the cistern (C 8) in Room R 73 (Photo Polish Archaeological Mission to Ptolemais).

Ryc. 40. Wlot cysterny (C 8) w pomieszczeniu R 73.



Fig. 41. Lime-burning kiln between the cistern (C 8) and Wall W 151 (Photo Polish Archaeological Mission to Ptolemais).

Ryc. 41. Wapiennik znajdujący się między wlotem do cysterny C 8 a murem W 151.



Fig. 42. General view of the stone pavement (R 68) with Rooms R 30 and R 32 in the foreground (Photo Polish Archaeological Mission to Ptolemais).

Ryc. 42. Widok ogólny na kamienne płytowanie w pomieszczeniu R 68; na pierwszym planie pomieszczenia R 30 i R 32.

Fig. 44. Rectangular pool (impluvium) lined with mosaic (M 16) in the courtyard (R 68) (Photo Polish Archaeological Mission to Ptolemais).

Ryc. 44. Prostokątny basen (impluvium) wyłożony mozaiką (M 16) w pomieszczeniu R 68.

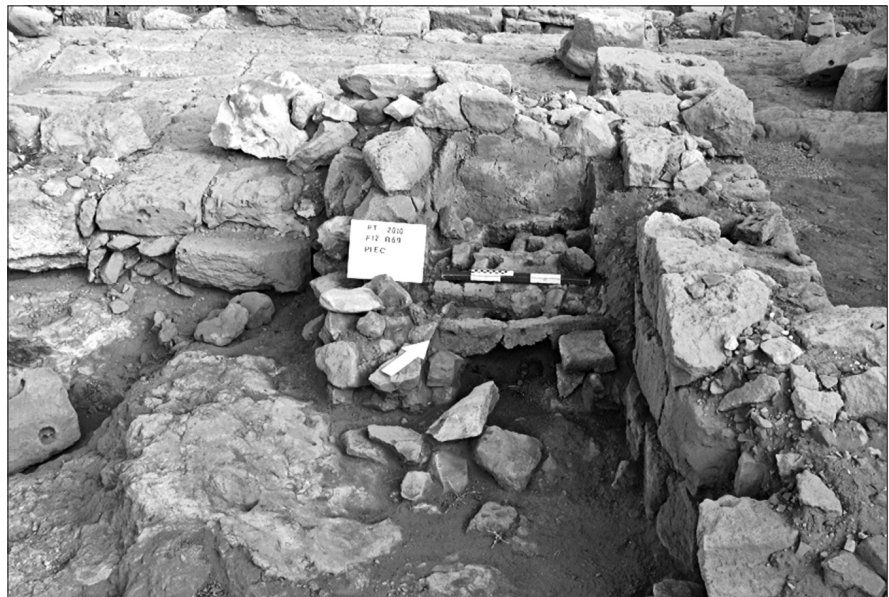

Fig. 45. Kiln (K 4) built into an original impluvium (R 68) (Photo Polish Archaeological Mission to Ptolemais).

Ryc. 45. Piec wbudowany w pierwotne impluvium (R 68).



Fig. 46. Aerial view of the apsed hall – R 65 (Photo M. Bogacki).

Ryc. 46. Widok z latawca na salę z apsydą R 65.



PLATE 18



Fig. 47. Architectural elements recorded inside Room R 65 (Photo Polish Archaeological Mission to Ptolemais).

Ryc. 47. Fragmenty architektoniczne zadokumentowane w obrębie pomieszczenia R 65.



Fig. 48. Aerial view of Room R 25 with the geometric mosaic floor (M10) (Photo M. Bogacki).

Ryc. 48. Widok z latawca na mozaikę geometryczną (M 10) w pomieszczeniu R 25.



Fig. 49. Room R 74 with a stone paving (Photo Polish Archaeological Mission to Ptolemais).

Ryc. 49. Kamienne płytowanie w pomieszczeniu R 74.

Fig. 50. Sequence of rooms (R 74, R 76 and R 79) with preserved thresholds (Photo Polish Archaeological Mission to Ptolemais).

Ryc. 50. Ciąg pomieszczeń (R 74, R 76 i R 79) z zachowanymi progami.



Fig. 51. Room R 79 (Photo Polish Archaeological Mission to Ptolemais).

Ryc. 51. Pomieszczenie R 79.



Fig. 52. Mouth of the cistern (C 5) in the courtyard (R 46) (Photo Polish Archaeological Mission to Ptolemais).

Ryc. 52. Wlot cysterny C 5 na dziedzińcu R 46.

PLATE 20

Fig. 53. Kiln (K 1) in Room R 45 adjacent to the courtyard (R 46) (photo Polish Archaeological Mission to Ptolemais).

Ryc. 53. Piec K 1 w pomieszczeniu R 45, w sąsiedztwie dziedzińca R 46.

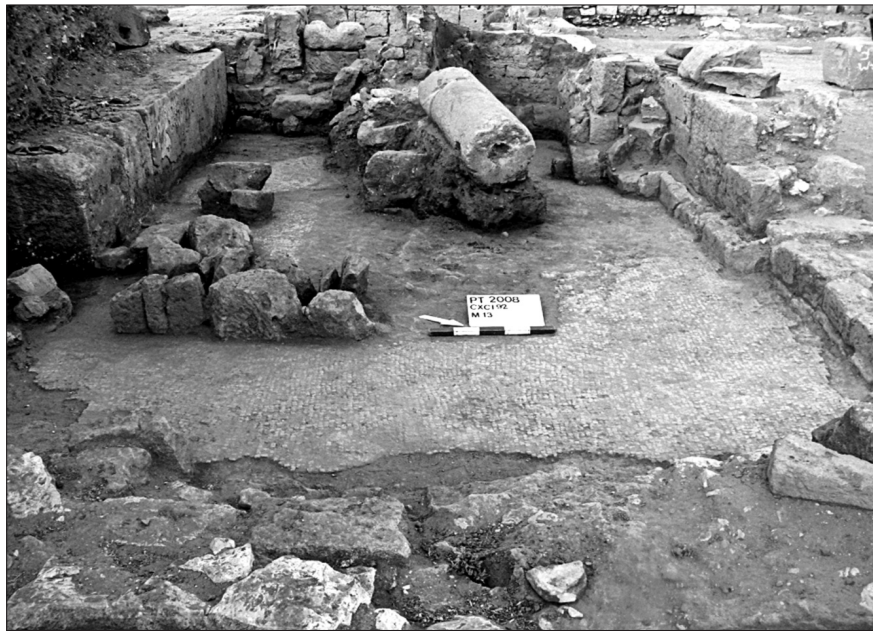
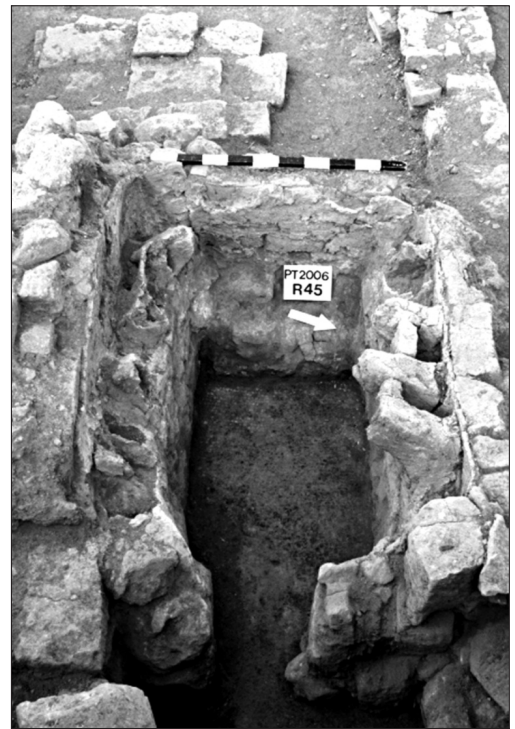

Fig. 54. Kiln (K 1) superimposed directly on top of the mosaic floor (M 13) (photo Polish Archaeological Mission to Ptolemais).

Ryc. 54. Piec K 1 posadowiony bezpośrednio na mozaice M 13.



Fig. 55. Aerial view of the area excavated in 2008–2009 (Photo M. Bogacki).

Ryc. 55. Widok z latawca na obszar badany w latach 2008–2009.

PLATE 21



Fig. 56. View of the area excavated in 2008 in the eastern part of the insula (Photo Polish Archaeological Mission to Ptolemais).

Ryc. 56. Widok obszaru badanego w 2008 r. we wschodniej części insuli.

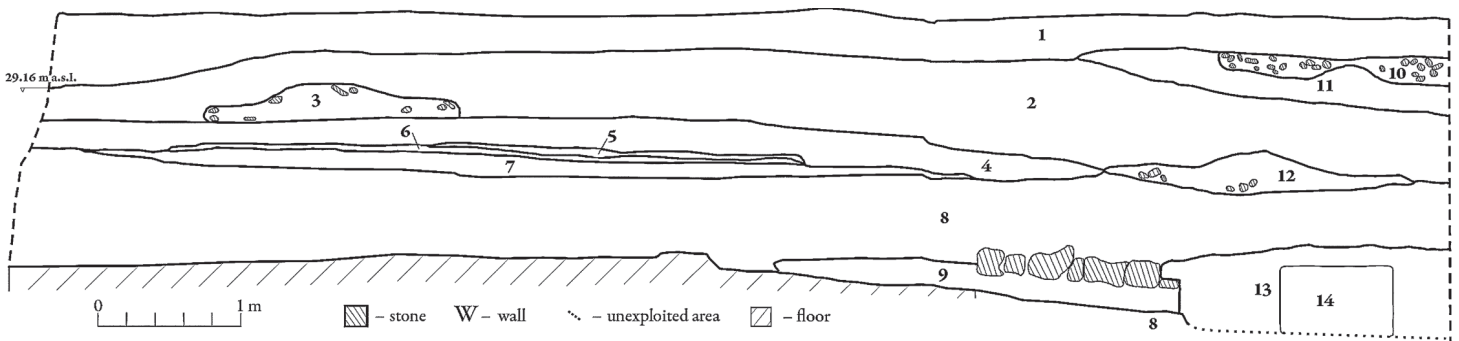

Fig. 57. NE-SW section above the courtyard R 46 (drawn in 2009 by K. Szajkowska, M. Bajtler, elaborated by Z. Kowarska, S. Lenarczyk). Layers: 1. greyish brown soil (Unit 01/09); 2. greyish brown soil mixed with small stones (Unit 10/09); 3. greyish brown soil mixed with small stones and many fragments of pottery; 4. pale brown hardened soil (Unit 27/09); 5. light grey soil; 6. reddish brown soil; 7. soil mixed with ash (Unit 35/09); 8. pale brown soil (Unit 38/09); 9. very light grey kind of mortar (Unit 41/09); 10. paving (Unit 17/09); 11. greyish brown clayey soil (Unit 22/09); 12. greyish brown soil mixed with stones and fragments of pottery; 13. greyish brown soil; 14. robber trench of W 164.

Ryc. 57. Profil NE-SW przez warstwy nad dziedzińcem R 46. Warstwy: 1. szarobrązowa ziemia (jedn. stratygraficzna 01/09); 2. szarobrązowa ziemia przemieszana z niewielkimi kamieniami (jedn. stratygraficzna 10/09); 3. szarobrązowa ziemia przemieszana z niewielkimi kamieniami i dużą ilością fragmentów ceramiki; 4. jasnobrązowa zbita ziemia (jedn. stratygraficzna 27/09); 5. jasnoszara ziemia; 6. czerwono-brązowa ziemia; 7. ziemia przemieszana z popiołem (jedn. stratygraficzna 35/09); 8. jasnobrązowa ziemia (jedn. stratygraficzna 38/09); 9. jasnoszara warstwa zaprawy (jedn. stratygraficzna 41/09); 10. płytowanie /posadzka; 11. szarobrązowa gliniasta ziemia (jedn. stratygraficzna 22/09); 12. szarobrązowa ziemia przemieszana z kamieniami i fragmentami ceramiki; 13. szarobrązowa ziemia; 14. negatyw muru W 164.

Fig. 58. General view of the courtyard (R 46) from N in 2009 (Photo Polish Archaeological Mission to Ptolemais).

Ryc. 58. Widok ogólny dziedzińca R 46 od północy w 2009 r.



PLATE 22



Fig. 59. General view of the courtyard (R 46) from S in 2009 (Photo Polish Archaeological Mission to Ptolemais).

Ryc. 59. Widok ogólny dziedzińca R 46 od południa w 2009 r.



Fig. 60. Room R 81 to the north of the courtyard (R 46) (Photo Polish Archaeological Mission to Ptolemais).

Ryc. 60. Pomieszczenie R 81 na północ od dziedzińca R 46.



Fig. 61. Room R 80 with a profiled base (Photo Polish Archaeological Mission to Ptolemais).

Ryc. 61. Pomieszczenie R 80 z profilowaną bazą.

Fig. 62. Doorway between Rooms R 80 and R 81 (Photo Polish Archaeological Mission to Ptolemais).

Ryc. 62. Przejście pomiędzy pomieszczeniami R 80 i R 81.



Fig. 63. Rooms closing the courtyard (R 46) from the east with partly preserved mortar floors (Photo Polish Archaeological Mission to Ptolemais).

Ryc. 63. Pomieszczenia znajdujące się na wschód od dziedzińca R 46 z częściowo zachowanymi podłogami z zaprawy.

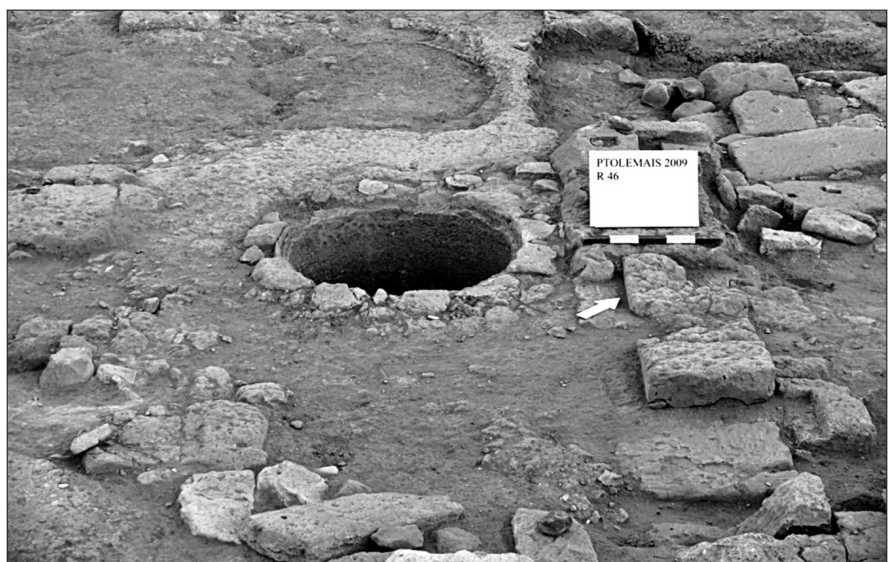

Fig. 64. Storage Vat V 3 in the courtyard (R 46) (Photo Polish Archaeological Mission to Ptolemais).

Ryc. 64. Zbiornik V 3 w posadzce dziedzińca R 46.

PLATE 24



Fig. 65. Storage Vats V 1 and V 2 in Room R 75 (Photo Polish Archaeological Mission to Ptolemais).

Ryc. 65. Zbiorniki V 1 i V 2 w posadzce pomieszczenia R 75.



Fig. 66. Storage Vats V 1 and V 2 in Room R 75 after the exploration (Photo Polish Archaeological Mission to Ptolemais).

Ryc. 66. Zbiorniki V 1 i V 2 w posadzce pomieszczenia R 75 po zakończeniu eksploracji.



Fig. 67. Storage Vats V 4 and V 5 in Room R 52 (Photo Polish Archaeological Mission to Ptolemais).

Ryc. 67. Zbiorniki V 4 i V 5 w posadzce pomieszczenia R 52.

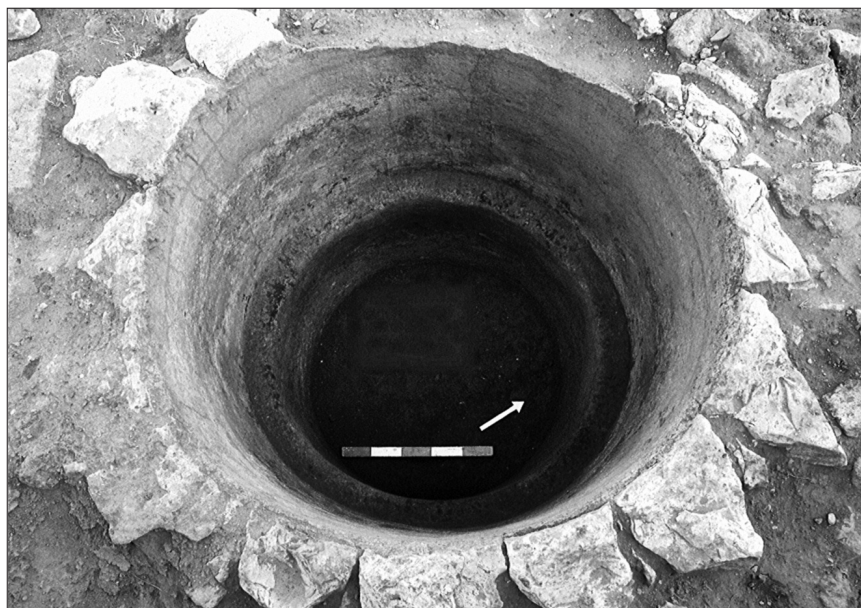

Fig. 68. Storage Vat V 1 after the exploration (Photo Polish Archaeological Mission to Ptolemais).

Ryc. 68. Zbiornik V 1 po eksploracji.

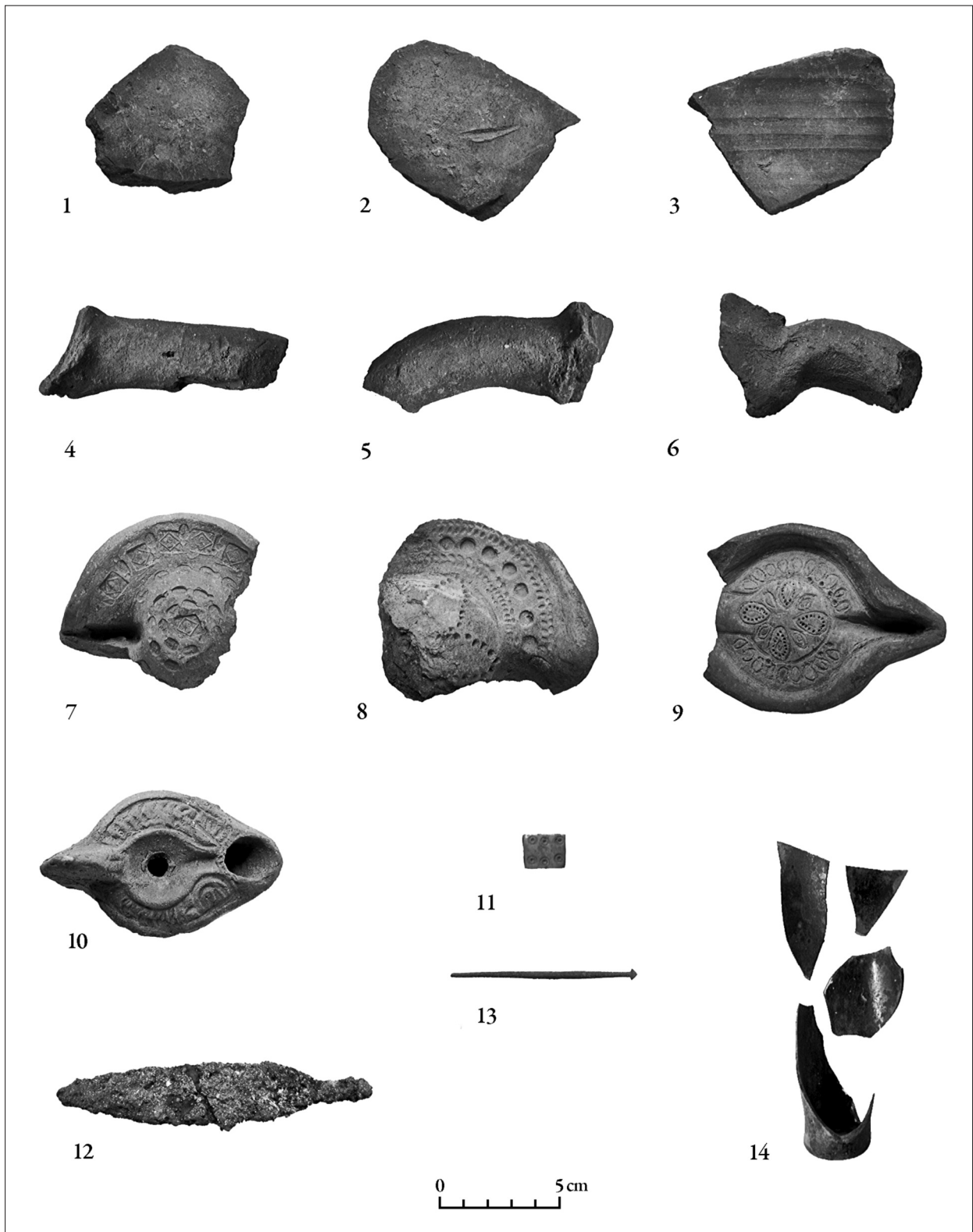

Fig. 69. Selected objects from explored storage vats: 1–6 – unbaked vessel fragments, 7–9 – lamp moulds, 10 – Late Roman lamp, 11 – game dice, 12 – spearhead, 13 – pin, 14 – fragment of a glass vessel (Photo Polish Archaeological Mission to Ptolemais).

Ryc. 69. Wybrane przedmioty znalezione podczas eksploracji zbiorników: 1–6 – fragmenty niewypalonych naczyń, 7–9 – formy do wypału lampek, 10 – lampka późnorzymska, 11 – kostka do gry, 12 – grot włóczni, 13 – szpila kościana, 14 – fragment szklanego naczynia



PLATE 26



Fig. 70. Storage Vat V 1 (Photo Polish Archaeological Mission to Ptolemais).

Ryc. 70. Zbiornik V 1.

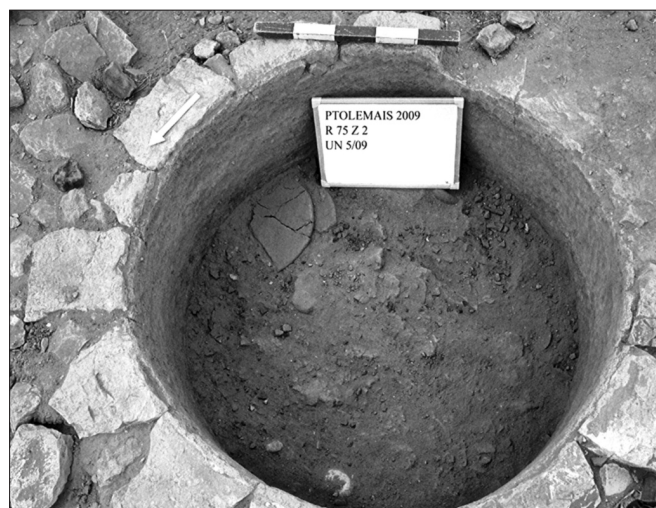

Fig. 71. Storage Vat V 2, a layer of unbaked clay matrix (Photo Polish Archaeological Mission to Ptolemais).

Ryc. 71. Zbiornik zasobowy V 2, warstwa niewypalanej masy ceramicznej przemieszanej z fragmentami niewypalonych naczyń.



Fig. 72. Storage Vat V 3 at the beginning of exploration (Photo Polish Archaeological Mission to Ptolemais).

Ryc. 72. Zbiornik zasobowy V 3 na początku eksploracji.



Fig. 73. Storage Vat V 3 after the exploration (Photo Polish Archaeological Mission to Ptolemais).

Ryc. 73. Zbiornik zasobowy V 3 po zakończeniu eksploracji.

Fig. 74. Storage Vat V 5 in Room R 52 after the exploration (Photo Polish Archaeological Mission to Ptolemais).

Ryc. 74. Zbiornik zasobowy V 5 w pomieszczeniu R 52 po zakończeniu eksploracji.



Fig. 75. Metallurgical furnace installed in the latrine (R 49) (Photo Polish Archaeological Mission to Ptolemais).

Ryc. 75. Piec metalurgiczny zainstalowany w latrynie (R 49).



Fig. 76. Room R 44 with a terracotta dolium (Photo Polish Archaeological Mission to Ptolemais).

Ryc. 76. Pomieszczenie R 44 z terakotowym dolium.



PLATE 28



Fig. 77. Remains of the decoration on the east wall (W 98) in Room R 50 (Photo Polish Archaeological Mission to Ptolemais).

Ryc. 77. Pozostałości dekoracji na ścianie wschodniej (W 98) w pomieszczeniu R 50.



Fig. 78. Remains of the decoration on the wall (W 102) to the east of the entrance to Room R 48 (Photo Polish Archaeological Mission to Ptolemais).

Ryc. 78. Pozostałości dekoracji na ścianie W 102, na wschód od wejścia do pomieszczenia R 48.



Fig. 79. Reconstruction of paintings (1<sup>st</sup> phase) on Wall W 102 (elaborated by R. Tusznió).

Ryc. 79. Rekonstrukcja malowideł (faza 1.) na murze W 102.

Fig. 80. Remains of the decoration on the wall (W 101) to the west of the entrance to Room R 48 (Photo Polish Archaeological Mission to Ptolemais).

Ryc. 80. Pozostałości dekoracji muru W 101 na zachód od wejścia do pomieszczenia R 48.

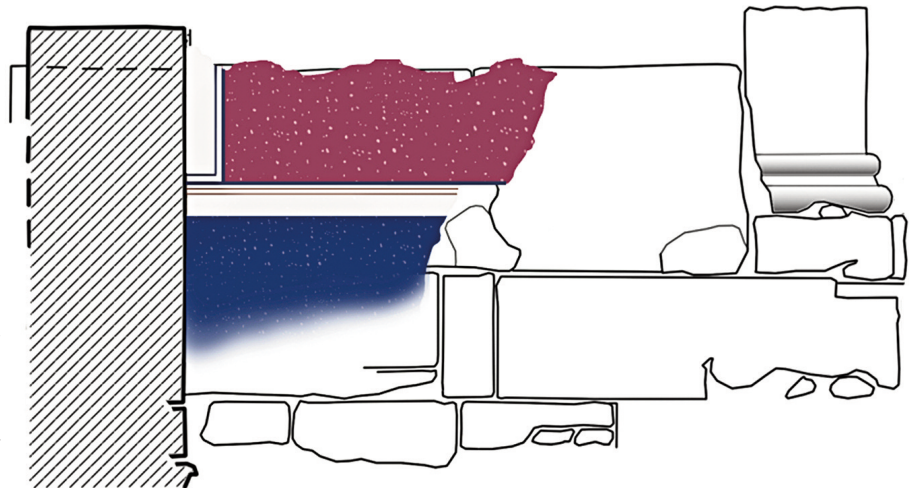

Fig. 81. Reconstruction of paintings (1<sup>st</sup> phase) on Wall W 101 (elaborated by R. Tusznió).

Ryc. 81. Rekonstrukcja malowideł (faza 1.) na murze W 101.

Fig. 82. Remains of the decoration on the west wall (W 132) in Room R 48 (Photo Polish Archaeological Mission to Ptolemais).

Ryc. 82. Pozostałości dekoracji muru zachodniego (W 132) w pomieszczeniu R 48.



PLATE 30



Fig. 83. Remains of the decoration on the east wall (W 149) in Room R 5 (Photo Polish Archaeological Mission to Ptolemais).

Ryc. 83. Pozostałości dekoracji muru wschodniego (W 149) w pomieszczeniu R 52.

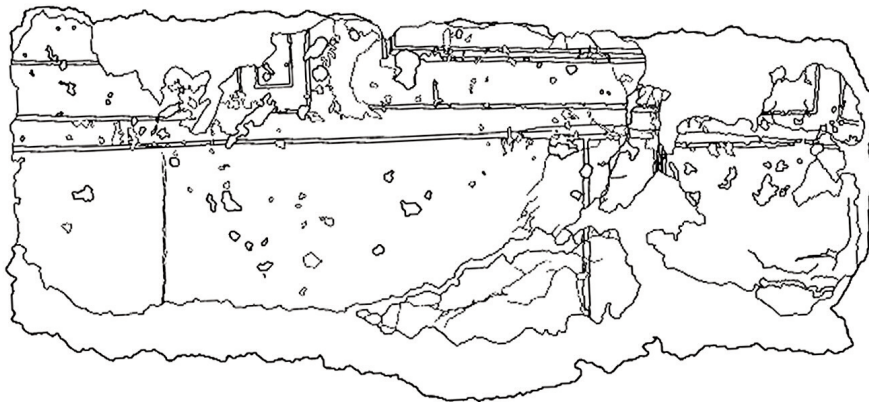

Fig. 84. Reconstruction of paintings on Wall W 149 (elaborated by R. Tusznió).

Ryc. 84. Rekonstrukcja malowideł na murze W 149.

Fig. 85. Protection of painting surface (W 3 in the corner of R 9) before transfer (Photo Polish Archaeological Mission to Ptolemais).

Ryc. 85. Zabezpieczenie powierzchni malowidła (mur W 3 w narożniku pomieszczenia R 9) przed transferem.



Fig. 86. Cutting away and transferring of the painting (W 3 in the corner of R 9) (Photo Polish Archaeological Mission to Ptolemais).

Ryc. 86. Odcinanie i transport malowideł (mur W 3 w narożniku pomieszczenia R 9).



Fig. 87. Painting (W 3 from R 9) after conservation in the Tolmeita (Ptolemais) Museum (Photo Polish Archaeological Mission to Ptolemais).

Ryc. 87. Malowidło (mur W 3 w pomieszczeniu R 9) po konserwacji w Muzeum Tolmeity (Ptolemais).



PLATE 32



Fig. 88. L. Calpurnius Frugi, denarius (inv. No. Cn/089/07) (Photo P. Jaworski).

Ryc. 88. Denar L. Calpurniusa Frugi.



Fig. 89. Quadrans of Scato (inv. No. Cn/137/08) (Photo P. Jaworski).

Ryc. 89. Kwadrans Scatona.



Fig. 90. Halved as of Kaligula (inv. No. Cn/013/09) (Photo P. Jaworski).

Ryc. 90. Przepołowiony as Kaliguli.



Fig. 91. Halved as of Lollius struck at Knossos (inv. No. Cn/060/08) (Photo P. Jaworski).

Ryc. 91. Przepołowiony as Lolliusa wybity w Knossos.



Fig. 92. Didrachma of Magas with a portrait of Berenike I (inv. No. Cn/113/07) (Photo P. Jaworski).

Ryc. 92. Didrachma Magasa z portretem Berenike I.



Fig. 93. Quadrans of Aulus Pupius Rufus (Photo P. Jaworski).

Ryc. 93. Kwadrans Aulusa Pupiusa Rufusa.

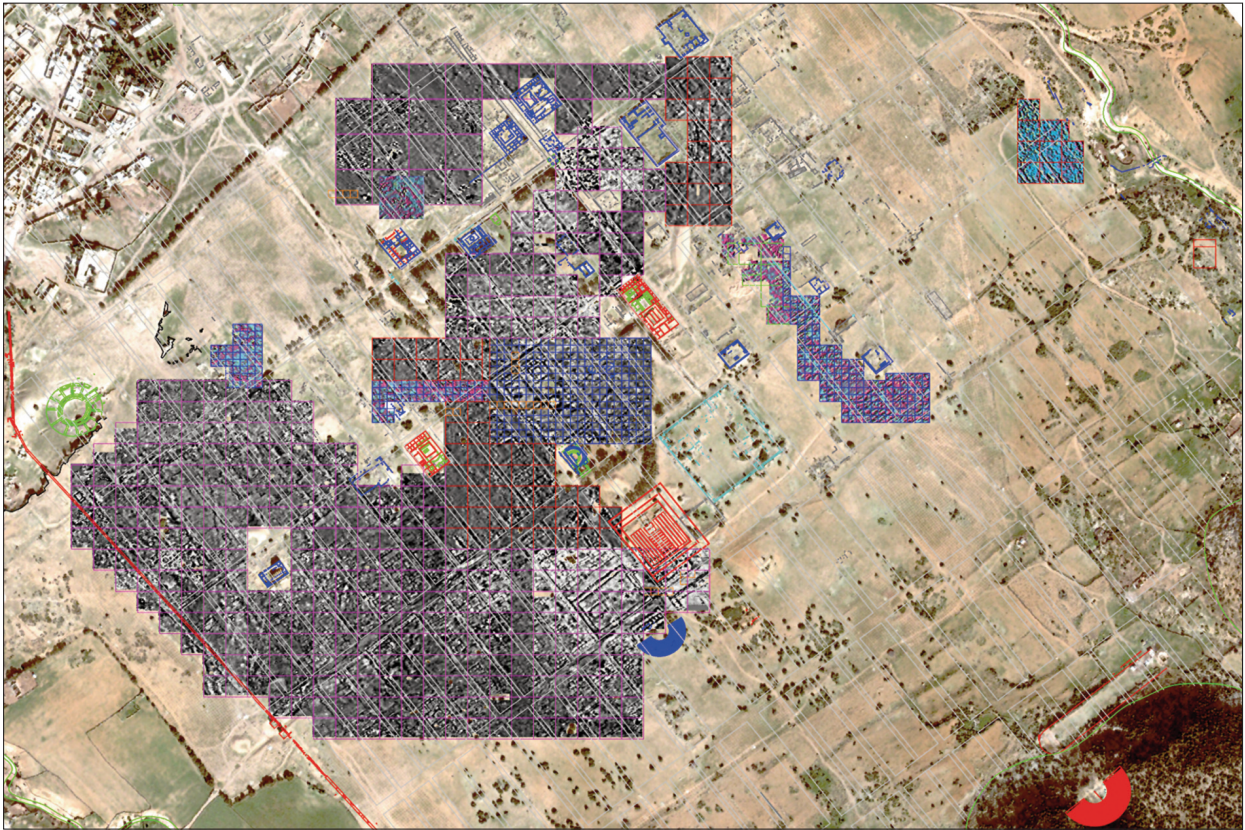

Fig. 94. Ptolemais 2006–2009. Data from geophysics, satellite images and aerial photography processed to the form of ortho-photo map. Gray scale maps present results of measurements carried out with a Geometrics G-858 cesium magnetometer and a Bartington 602-dual gradiometer, blue and red illustrate results of survey with a PMP-8 proton precision magnetometer (by W. Małkowski and K. Misiewicz).

Ryc. 94. Ptolemais 2006–2009. Dane z badań geofizycznych, zdjęć satelitarnych i fotografii latawcowej przetworzone w formę ortofotomapy. Kolor szary ukazuje wyniki pomiarów przeprowadzonych za pomocą magnetometru cezowego i gradiometru Bartington 602; niebieski i czerwony obrazują wyniki badań przy pomocy magnetometru protonowego PMP-8.

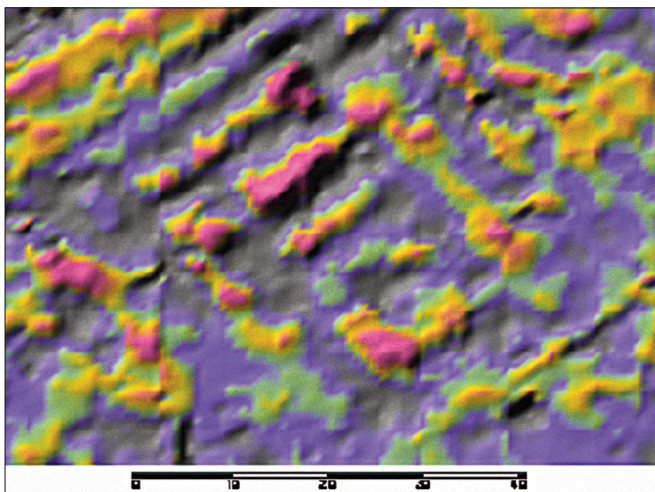

Fig. 95. Detailed plan of architectural remains localised in the northern part of surveyed field. Horizontal-gradient measurements with the geometrics G-858 cesium magnetometer (by W. Małkowski and K. Misiewicz).

Ryc. 95. Dokładny plan pozostałości architektonicznych zlokalizowanych w północnej części badanego obszaru. Pomiary gradientu poziomego przeprowadzone za pomocą magnetometru cezowego G-858.

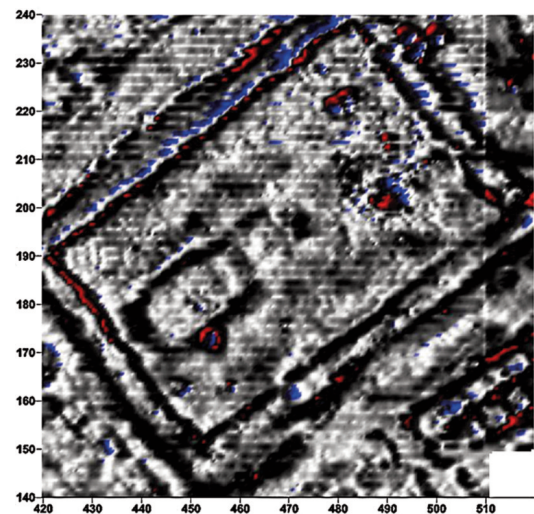

Fig. 96. Magnetic anomalies registered in the southern part of Ptolemais caused probably by the remains of a Roman temple (?) (by W. Małkowski and K. Misiewicz).

Ryc. 96. Anomalie magnetyczne zadokumentowane w południowej części Ptolemais spowodowane prawdopodobnie pozostałościami rzymskiej świątyni (?).