

Ewdoksia Papuci-Władyka

Nea Paphos: The Cistern South of the Villa of Theseus

Polish Archaeology in the Mediterranean 9, 130-135

1998

Artykuł został opracowany do udostępnienia w internecie przez Muzeum Historii Polski w ramach prac podejmowanych na rzecz zapewnienia otwartego, powszechnego i trwałego dostępu do polskiego dorobku naukowego i kulturalnego. Artykuł jest umieszczony w kolekcji cyfrowej bazhum.muzhp.pl, gromadzącej zawartość polskich czasopism humanistycznych i społecznych.

Tekst jest udostępniony do wykorzystania w ramach dozwolonego użytku.

NEA PAPHOS

THE CISTERN SOUTH OF THE VILLA OF THESEUS

Ewdoksia Papuci-Władyka

In 1996, a plastered cistern was found during excavations south of the Villa of Theseus.¹ Its exploration was finished by the end of September 1997.² The shaft of the cistern was reused as a bin, in which two practically intact vessels were found: a kitchen pot (fig. 1: 2) and a plate of Eastern Sigillata A (ESA) Hayes form 29 (fig. 1:1)³ dated from about 30 BC to AD 20/25. These may be interpreted as remains of contemporary kitchen use.

In 1997, continued explorations of the fill below the shaft (a depth of c. 3.00 m had been reached in 1996) revealed the bottom at an unexpected level of barely 3.50 m. The cistern is piriform in section and has a short recess of unexplained function, leading northeastward and slightly upward from its almost flat bottom.

The cistern evidently remained long in use. Large amounts of pottery were found, mostly broken, but in many cases mendable enough for the sections to be restored, and in some cases the entire vessels (over 80 more or less completely mended pieces). Other finds beside the pottery included coins, stamped amphora handles, oil lamps, glass, metal, stone and other objects,⁴ as well as

¹ W. A. Daszewski, Nea Paphos: Excavations 1996, *PAM VIII*, 1996 (1997), pp. 119-120, phot. 2.

² The cistern and the pottery from it was presented briefly by H. Meyza and the present author at the international conference: *Jagiellonian University. Centenary of Mediterranean Archaeology, 1897-1997*, held in Kraków in October 1997 (to be published).

³ J.W. Hayes, *Sigillate orientali*, in: *EAA Atlante II*, Roma 1985, pp. 13, 27, pl. IV.

⁴ These have been identified by other members of the expedition staff: W.A. Daszewski who identified the coins, Z. Sztetyło who commented upon amphora stamps, and J. Młynarczyk who kindly classified and suggested dates for the lamps.

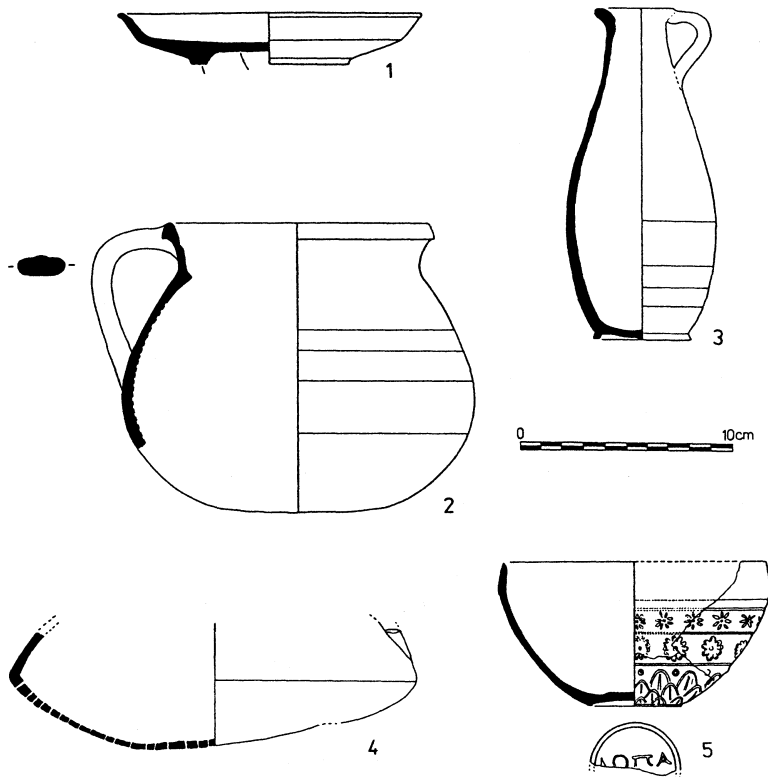

Fig. 1. Pottery found in the cistern south of the Villa of Theseus.

various odds and ends: a gem fragment, beads, small glass pendants (one in the form of Harpocrates), etc.

Close to 30 bronze coins were found. Among those that could be cleaned, the latest is one dating probably to the reign of Cleopatra VII (No. 749, at 163 cm), while the two from the layer at the very bottom (Nos 798 and 799) belong to Ptolemy X Alexander I (107-88 BC). The amphora stamps are mainly Rhodian (12), dating mostly to the second half of the 2nd cen-

tury BC. Occurring in the lower part of the deposit are stamps dating from the fifth period of Rhodian amphorae, e.g. the stamps of Midas and Aristanax, dating to 146-108 BC. Originating from the same period is a Cnidian amphora, restored from pieces found mainly in the loose part of the lower fill at a depth of 326-338 cm, most probably of these *duoviri*, but with almost obliterated stamps. On the other hand, the Rhodian amphora neck, which has also been found in the lower fill, dates probably to the third period with the stamps of the potter Menekratos and the eponym Aristeides. The latest lamp, a moulded kite-form of grey ware with Eroses in the decoration, found in the lower strata, belongs to the end of the 2nd or early 1st century BC, and is contemporary with the above mentioned coins. Two lamps of the type with a pair of embracing lovers were found in the upper part of the deposit. The dominating lamp type, however, is the sub-Rhodian wheel-made form, which seems to have been produced in Cyprus in the second half of the 2nd century BC, if not earlier.

The sequence of the typological presentation follows the frequency of occurrence in the main groups: tableware and domestic wares. Among the tableware, the Color Coated Ware, a characteristic Cypriot Hellenistic class of pottery,⁵ is the most numerous. Apart from ubiquitous bowls with in-turned rim and plates with a variety of rims, an example of a well-preserved jug of this ware was restored from pieces. The forms represented were: *olpe* (fig. 1:3), narrow-necked jug⁶ similar to examples from the House of Dionysos, small feeding jug,⁷ large jug with the upper part slip-ped red (fig. 2:1) etc. All these are datable to the Late Hellenistic

⁵ J.W. Hayes, *Paphos III, The Hellenistic and Roman Pottery*, Nicosia 1991, pp. 26-31; E. Papuci-Władyka, *Nea Paphos. Studia nad ceramiką hellenistyczną z polskich wykopalisk (1965-1991)*, Kraków 1995, pp. 47-54.

⁶ Hayes, *Paphos III*, o.c., fig. 54, 28.

⁷ *Ibidem*, p. 145, no 25, fig. 50.

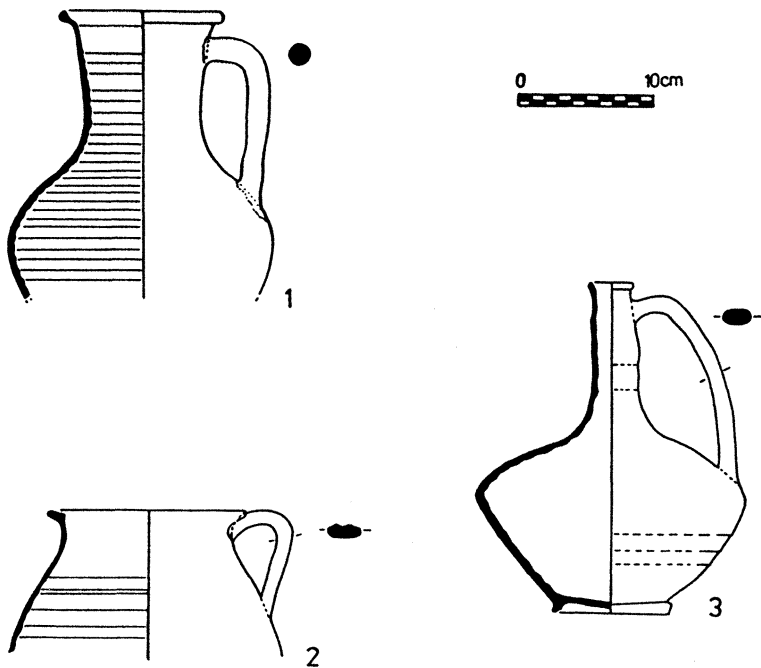

Fig. 2. Pottery found in the cistern south of the Villa of Theseus.

period, i.e., the second half of the 2nd and the first half of the 1st century BC.

Another class of tableware present among the finds is the Plain White Ware. It is not very numerous, as in other contexts dug by the Polish Mission.⁸ A thin-walled jug (fig. 2:2), preserved in part only, may serve here as an example.

Lagynoi are represented both by plain-slipped examples (fig. 2:3) and by fragments of painted vessels. Among the latter, those of likely Cyprus production are common, as are

⁸ Papuci-Władyka, *op.cit.*, pp. 54-60.

vessels imported probably from Asia Minor, made of a light brown paste with substantial quantities of micaceous impurities.

Imported relief mouldmade bowls ("Megarian") are also fairly numerous. No locally made bowls, as defined by P. Puppo (at the Fifth International Meeting on Hellenistic Pottery in Chania (Crete) in Spring 1997) and produced near Nicosia, were found here. As the available evidence from the House of Dionysos and the Polish excavations suggests, these bowls did not reach to the western part of the island. Only imported bowls are found, mostly from Ephesian workshops (formerly called "Delian"). All of these should be dated in the second half of the 2nd century BC or in the beginning of the next. One beautiful example with floral decoration (fig. 1:5) comes probably from the Apollonios workshop.⁹

Another group of fine-ware vessels consists of unguentaria. Several complete or fragmentary spindle-shaped balsamaria dated to the 2nd or 1st century BC have been found in the cistern.

Last but not least, there is quite a number of relatively well preserved Eastern Sigillata A vessels.¹⁰ Apart from plates forms 2 and 4, deep plates form 5A, and wide-rim plates form 6, there were several footed bowls form 22, mastoid profiled rim bowl form 17B, hemispherical to ovoid bowl form 18, hemispherical vertically gouged bowl form 19B, and a pine-cone relief bowl form 24. The paste of these vessels varies. Nevertheless, they seem homogeneous when compared with the evident imitations, e.g. of form 23, with flaky slip and small dark grits.

Generally, the bulk of the sherds belongs to common domestic wares, of which amphorae constitute the largest group. They are mostly Rhodian, with a few Cnidian and local, e.g. Kourion

⁹ A. Laumonier, *La céramique hellénistique – reliefs. Ateliers "ioniens"*, in: *EAD XXXI*, 1, 1997, pp. 223 ff, pls 50-51.

¹⁰ For ESA forms, see: Hayes, *EAA Atlante II*, pp. 9-48, pls I-XI.

fragments. Some observations were made on the amphora stamps and two better preserved vessels, but more time is needed than was available in order to restore any sizable quantity of transport amphorae.

Kitchen cooking ware is plentiful, but few vessels were restored owing to the brittleness of the sherds, which makes it immensely difficult to attribute the small pieces to a particular vessel. Apart from a fairly intact casserole, a section of another cooking pot, a colander (fig. 1:4),¹¹ was restored thanks to the characteristic perforated bottom. A deformed misfired pot was equally easily spotted and mended; this piece evidently suggests that a pottery workshop must have been situated nearby. A brazier attachment with a Silenus face and a wreath of wine is also related to the kitchen wares and so should be mentioned here; it represents a type which does not occur in the House of Dionysos.

At the present moment, we can say that the cistern's fill is not a primary dump with deposits slowly accumulating over the centuries. It seems that the cistern was used to redeposit a domestic dump of unusable pottery and minor objects; it is significant that there are no terracottas and relatively few stones in the fill. There are some ashes, but not really enough to suggest fire debris, inevitable if an earthquake were to be the cause of deposition. Therefore, the most probable source for the debris is a household dump removed from some nearby place after a speedy accumulation, possibly in consequence of some rebuilding.

¹¹ J.W. Hayes, *Paphos III*, o.c., p. 139, no. 100, fig. 34 top.