

Claire Malleson, Jozef Hudec, Sławomir Rzepka

Tell El-Retaba: Season 2009

Polish Archaeology in the Mediterranean 21, 107-123

2012

Artykuł został opracowany do udostępnienia w internecie przez Muzeum Historii Polski w ramach prac podejmowanych na rzecz zapewnienia otwartego, powszechnego i trwałego dostępu do polskiego dorobku naukowego i kulturalnego. Artykuł jest umieszczony w kolekcji cyfrowej bazhum.muzhp.pl, gromadzącej zawartość polskich czasopism humanistycznych i społecznych.

Tekst jest udostępniony do wykorzystania w ramach dozwolonego użytku.

TELL EL-RETABA SEASON 2009

Sławomir Rzepka,¹ Jozef Hudec²

with appendix by Claire Malleson³

¹ Institute of Archaeology, University of Warsaw, ² Aigyptos Foundation,

³ University of Liverpool

Abstract: The third season of fieldwork in Tell el-Retaba contributed significant information on site history in the New Kingdom and Third Intermediate Period. The discovery of a Ramesside infant cemetery is especially noteworthy, as it clarifies, among others, the chronology of the earliest fortifications on the site. Additional information was also collected on space organization inside the early and late Ramesside fortresses. Archaeobotanical studies were commenced this season. The results, presented in an appendix, have produced data on the ancient environment, in which the inhabitants of Retaba lived.

Keywords: Tell el-Retaba, New Kingdom, Third Intermediate Period, fortress, infant burials, archaeobotany

AREAS 1 AND 2

In its third season, the Polish–Slovak Archaeological Mission to Tell el-Retaba had planned to continue excavations from the previous year on the northern defense wall of the Ramesside fortress (Area 1) and domestic architecture from the Third Intermediate Period (Area 2). News of the impending construction of a second line of the asphalt road cutting across the site, received days into the current season, necessitated an immediate refocusing of archaeological priorities. Work in Areas 1 and 2 was suspended in favor of salvage excavations in Areas 3, 4 and 5 along the planned course of the road [*Fig. 1*].

AREA 1

Excavations were carried out in two trenches, Y250/X270 and Y255/X270, each 5 m square. After removing the sand backfill from trench Y250/X270, work continued around the oven and fireplace. A north–south section was dug between the northern defense wall and the southern side of the square.

The upper layers in square Y255/X270 proved to be extensively disturbed by earlier *sebakh* digging, as was the case already with trenches excavated in this area last year. At least two bigger and three smaller pits, the latter extending into the

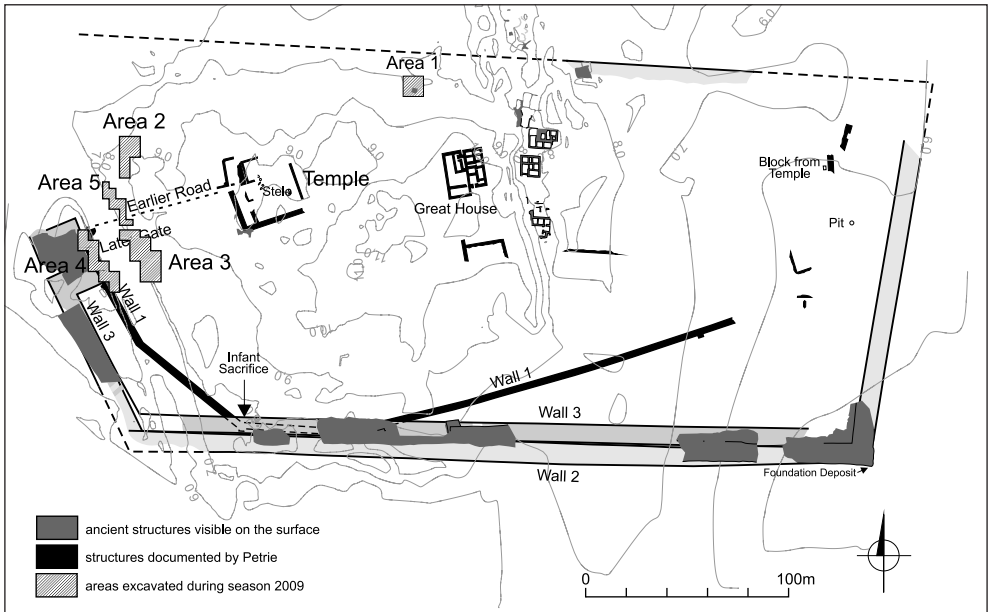

Fig. 1. Map of Tell el-Retaba showing ancient structures visible on the surface and areas excavated during the 2009 season (Drawing S. Rzepka)

Team

Dates of work: 29 September–28 October 2009

Directors: Dr. Sławomir Rzepka, archaeologist (Institute of Archaeology, University of Warsaw)

Deputy director: Dr. Jozef Hudec, archaeologist (Aigyptos Foundation, Bratislava)

SCA representative: Nassef Abdelwahed

Archaeologists: Kamila Braulińska (Institute of Archaeology, University of Warsaw), Veronika Dubcová (Faculty of Philosophy, University of Trnava), Karolina Górka (Institute of Archaeology, University of Warsaw), Sylwia Gromadzka (Institute of Archaeology, University of Warsaw), Lubica Zelenková (Institute of Egyptology, University of Vienna)

Ceramologists: Dr. Anna Wodzińska (Institute of Archaeology, University of Warsaw)

Archeobotanist: Claire Malleson (University of Liverpool)

Student-trainees: Mária Briliaková (Department of Archaeology, Comenius University in Bratislava), Joanna Ciesielska, Łukasz Jarmużek, Małgorzata Korzeniowska (all three Institute of Archaeology, University of Warsaw)

Acknowledgments

The help and support of the inspector representing the SCA, Mr. Nassef Abdelwahed, was invaluable to us. We would also like to thank Dr. Mohammed Abdel Maksoud, General Director of Lower Egypt, and Mr. Tarek Harash, General Director of the Ismailiya Area, for their involvement and assistance.

neighboring squares, were recorded. The northern defense wall appears to continue in the northern part of the square. It was damaged by the digging for fertile soil, but enough undisturbed deposits were found, partly covering the wall, to permit a reliable study of the stratigraphy in this area.

AREA 2

Work was continued in a Third Intermediate Period house, discovered in the previous season. The discovery of an iron blade, too badly corroded for positive identification (fragment of spearhead, knife or dagger?) [Fig. 2], considered together with an iron spearhead discovered last year in the same area, points to a greater commonness of iron in Retaba of the Third Intermediate Period than is generally assumed for Egypt of the time. The proximity of Palestine could be one explanation for this phenomenon, the Iron Age there having started much earlier than in Egypt. Iron was commonly used there

for tool and weapon production in the first half of the 1st millennium BC, even as bronze remained the chief material for -this purpose in Egypt. It must be assumed that the iron objects from Tell el-Retaba are imports, as so far there is no evidence of iron smelting in Egypt before the 6th century BC.



Fig. 2. Iron blade discovered in a Third Intermediate Period house in Area 2 (Photo K. Braulińska)

AREA 3

Mud-brick walls close to 1.50 m high had been observed in the section created in 2000 by the construction of the existing asphalt road (the one now to be widened) [Fig. 3]. Consequently salvage excavations were commenced at this point to determine the stratigraphy and dating of these remains. The youngest proved to represent the Late Period; they were superimposed on Third Intermediate Period remains with strata from the first half of the New Kingdom being reached in one place where digging could be continued to much deeper levels.

LATE PERIOD

Massive mud-brick walls, built of characteristic “bubble gum” bricks, which are dark brown and very porous, were approximately 1 m thick and stood 0.50 m high in places. They were generally rather poorly preserved, just one to two courses of bricks, and insufficient for a reconstruction of the layout of this architecture. Judging by the pottery from this much disturbed layer, the structure(s) probably belonged to the Late Period (although the later part of the Third Intermediate Period cannot be excluded).

THIRD INTERMEDIATE PERIOD
Two well preserved houses with walls rising to 1.50 m were partly excavated [Fig. 5]. They were dated securely to the Third Intermediate Period by an abundant pottery assemblage. The southern house

(2) has massive, one-meter thick walls, which could indicate the presence of an upper floor. The largest excavated room in this building (1) [Fig. 4], approximately 4 m by 5 m, demonstrated evidence of prolonged occupation (several floor levels)



*Fig. 3. General view of the domestic architecture in Area 3, looking northeast
(Photo K. Górka)*



*Fig. 4. Room 1 of House 2 in Area 3, view from the east
(Photo K. Górka)*

but no trace of either doors or windows despite walls rising to more than 1 m from the earliest floor level. It was apparently a basement accessed from an upper floor. A fireplace and three big storage jars [Fig. 6] were discovered in strata belonging to a later stage of occupation (both houses had evidently been rebuilt repeatedly still in the Third Intermediate Period). Fish bones and scales were found in two of the storage jars [Fig. 7]. Remains of this kind were generally frequent, proving the importance of fish in the diet of people living in these houses.

Fig. 5. Houses of the Third Intermediate Period in Area 3 (Plan S. Gromadzka, E. Jarmużek, S. Rzepka)

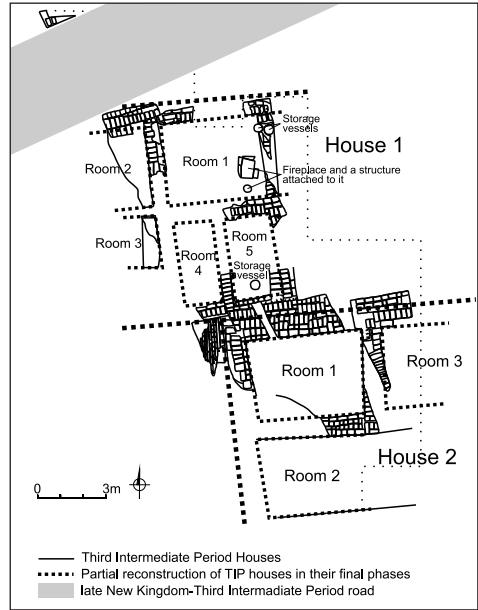

Fig. 6. Storage vessel in room 5 of House 1 in Area 3 (Photo K. Górka)



Fig. 7. Fish bones and scales from Third Intermediate Period house deposits
(Photo K. Górka)

TWENTIETH DYNASTY

No Third Intermediate Period building activity could be observed in a section about 5 m wide directly to the north of the complex of houses described above. This could have been an ancient road running E–W, from the big western gate (*migdol*) of the fortress toward the building identified by Petrie as a “temple” [see *Figs 1, 4*]. The *migdol* belonged to the fortress built by Ramesses III and the road was in use apparently during the Twentieth

Dynasty and the Third Intermediate Period. Only a small fragment was excavated. In the Late Period, the road was blocked by some buildings, little of which has survived.

NINETEENTH DYNASTY

Structures below the supposed ancient road from the late New Kingdom and Third Intermediate Period were dated to the Nineteenth Dynasty by the pottery assemblage and an analysis of stratigraphic relations. A mud-brick wall, approximately 0.60 m thick, ran N–S for a distance of at least 10 m (it was traced also in Area 5 to the north of Area 3) [*Fig. 8*]. Only two to three courses of bricks have been preserved, hence it is possible that the building was demolished intentionally. Its function, perhaps a barrack or a storeroom,¹ could not be determined, but it clearly belonged to the Nineteenth Dynasty fortress and was destroyed when a new, bigger fortress of Ramesses III constructed on a different plan replaced the older structure.

EIGHTEENTH DYNASTY

An older structure revealed directly underneath this wall foundation had very thin walls, measuring only about 0.20 m, i.e., one row of bricks [see *Fig. 8*]. It seems to have been a small house (or rather a hut) with a round silo to the west and a refuse pit to the north. The pottery assemblage could be dated to the first half of the Eighteenth Dynasty. This apparently poor private house was probably not part of the royal fortress.

¹ A parallel wall belonging to the same structure had been found further to the east in the 2010 season. The distance between these walls is 3.50 m, which corresponds to the width of long rooms in the barracks/workshops of the fortress of Ramesses II, discovered in 2010 in the southern part of the site.

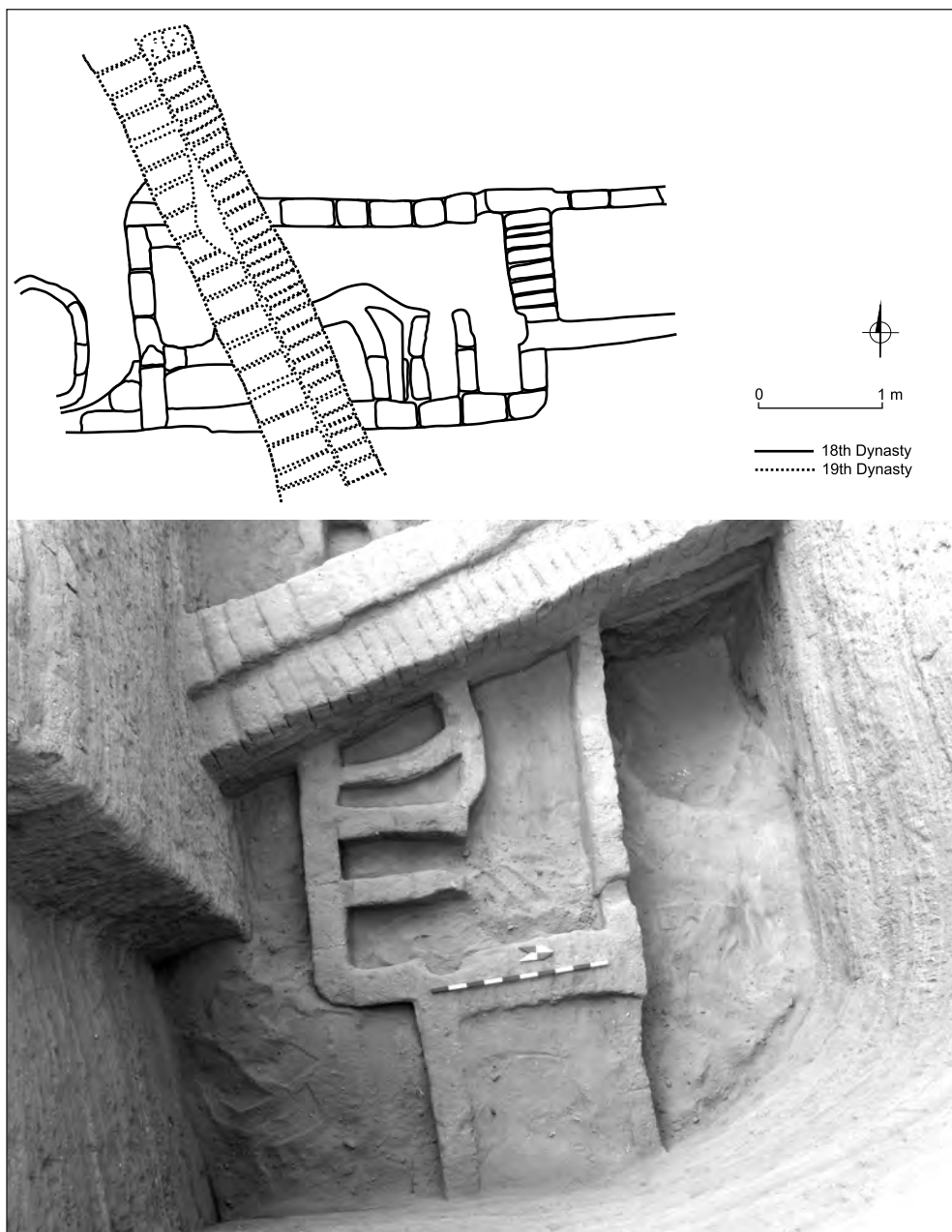

Fig. 8. Plan of structures discovered under the ancient road in Area 3 (top); wall of a Nineteenth Dynasty building and an Eighteenth Dynasty small house underneath (Photo K. Górka; drawing S. Gromadzka, E. Jarmużek)

A thick deposit of wind-driven sand separated the remains from dark silty layer with abundant pottery of early Eighteenth

Dynasty date. Excavations this season did not proceed below this level, approximately 4.50 m below the modern surface.

AREA 4

The western defense walls, among them Petrie's "wall 1", which is the earliest fortification on the site [Fig. 9], can be found in Area 4 located on the western side of the modern asphalt road [see Fig. 1]. Petrie was of the opinion that this wall should be dated to the First Intermediate Period and linked with foreign invaders: "we must rather look to a Syrian occupation

as the cause of this earliest fortification. To judge by the early age of remains here we might look to Syrian invaders after the Sixth Dynasty as likely builders" (Petrie, Duncan 1906: 29). His theory was based on the discovery of an infant burial, without any equipment, beneath his "wall 1", which he interpreted as an "infant sacrifice" made by "barbarian" Syrians.



Fig. 9. Remains of the oldest fortifications ("wall 1") in Area 4, cut by the modern road (Photo K. Górka)

Following the discovery this season of a group of similar infant burials on the east (internal) side of the wall, there is no question that Petrie was mistaken. Altogether there were remains of six burials: three with almost completely preserved skeletons inside jars, one skeleton without jar, one incomplete burial (only skull preserved) and one oval pit from a removed burial (see Górká, Rzepka 2011). All of the burials were located close to Petrie's "wall 1", on approximately the same level, some under this wall [Figs 10, 11]. The children buried here were aged about 10–12 months. In three instances jars were used as coffins

[Fig. 12]. The amphorae were identified by Anna Wodzińska as type B1 in Aston's typology (Aston 2004: 187): ovoid, elongated bodies, long necks and small handles attached at maximum body diameter. Containers of this kind were produced all through the New Kingdom, their specific line of development making them slender and taller over time. They were used as containers and transportation vessels for food and liquids (Hope 1989: 93, 98). The shape of the jars found in Tell el-Retaba is most typical of the Nineteenth Dynasty, specifically the times of Ramesses II (Aston 2004: 189, Fig. 7[b,d,e]; Hope 1989: Figs 2.3, 2.4,

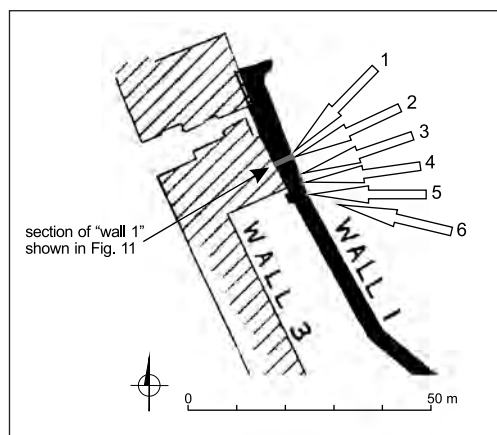
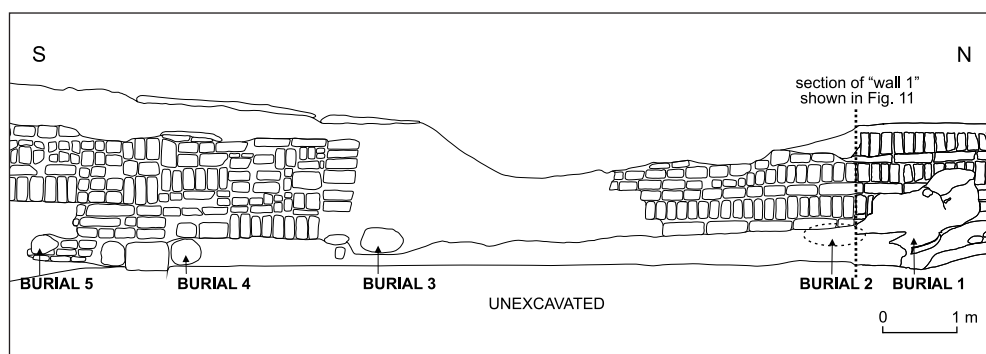

Fig. 10. Location of six infant burials in Area 4 (left) and relative to "wall 1", view here of the east facade (top) (Drawing S. Rzepka (left), K. Górká, Ł. Jarmużek)



Fig. 11. Infant burials no. 1 (left) and no. 4 (right) in Area 4
(Photo K. Górka)

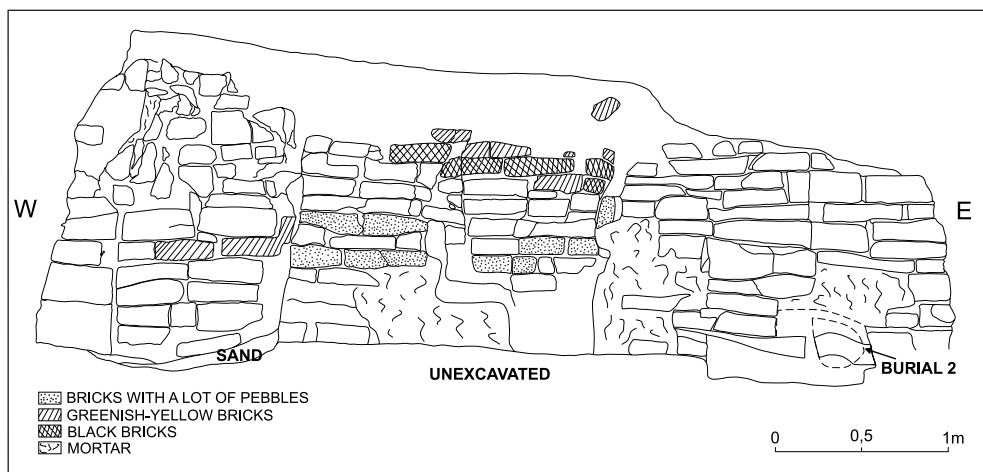

Fig. 12. Infant burial no. 2, discovered below
“wall 1” (right) and location of the burial
in a section drawing of the wall (Photo
K. Górka, drawing M. Korzeniowska,
J. Ciesielska, Ł. Jarmużek)



2.7; Aston 1997: Pl. 120[160, 161]) (see Wodzińska 2012: 127, in this volume).

The infant burials thus seem to indicate that Petrie's "wall 1" was built during the reign of Ramesses II or later. However, "wall 1" is not a uniform structure and would have been built, contrary to Petrie's opinion, in several stages. The final building phase of "wall 1", its eastern extension, should be dated to the Nineteenth Dynasty.² There can

be no question of any involvement on the part of "Syrian" invaders.

Despite the havoc wrought on the stratigraphic relations by trenches under two modern pipelines running along the western side of the existing asphalt road, it was possible to determine that the infant cemetery overlay ruins of a settlement comprising some evidence of silos. Pottery from the settlement layers is attributable to the early New Kingdom.

AREA 5

Area 5 is situated directly north of the "ancient road" in Area 3 [see *Fig. 1*]. Remains of mud-brick structures discovered there were generally in worse condition than those from Area 3 and unlike those despite being of the same Third Intermediate

Period date. Walls were thin, approximately 0.30 m, some even thinner, built of only one row of bricks. The discovery in this area of three ovens [*Fig. 13*] and a large round silo (approximately 2.50 m in diameter) is significant, as nothing of the sort was



Fig. 13. Two Third Intermediate Period furnaces discovered in Area 5 (Photo K. Górka)

² Excavations in the 2010 season confirmed the dating of the core of "wall 1" to the Nineteenth Dynasty.

observed in Area 3. Therefore, Area 3 appears to have been of a domestic nature and consisted of houses of substantial size, including storied structures, while the area to the north may have served some “industrial” purposes. It should be noted that the northern part of the fortress was occupied by industrial (ovens) and storage facilities (silos) already during the late

New Kingdom, as observed in Area 1 and in the excavations carried out by Egyptian missions in the 1980s and 1990s. Caution is recommended, however, as the excavations have covered only a limited area so far and because there have been so far no finds of domestic buildings of New Kingdom date apart from Petrie’s Great House.

[SR, JH]

CONCLUSIONS

The third season of the PCMA’s Polish–Slovak Archeological mission in Tell el-Retaba has brought a number of significant results (for an extensive report on the 2009 and 2010 season, see Rzepka *et alii*, forthcoming). Firstly, there is now solid archaeological evidence for dating of the earliest fortifications on the site to the Nineteenth Dynasty and not to the First Intermediate Period, as supposed by Petrie).

Secondly, the discovery of an ancient road has shown that the rebuilding

of the fortress by Ramesses III during the Twentieth Dynasty changed completely not only the defense walls, but also the spatial organization of the fortress. This new organization was respected in the Third Intermediate Period and was changed in the Late Period.

Thirdly, modest domestic architecture from the early Eighteenth Dynasty suggests that at that time only a poor settlement and not a royal fortress existed on the site.

[SR, JH]

APPENDIX

TELL EL-RETABA, ARCHAEOBOTANICAL STUDIES

Claire Malleson

University of Liverpool

An assessment of the archaeobotanical remains was undertaken in the 2009 season in order to ascertain the potential of the material to answer research questions relating to ecology, environment, subsistence and agriculture. Based on the location of this site in the flood-plain area, i.e., not in the desert, it was assumed

that the preservation of plant remains by desiccation was highly unlikely. Thus, all results discussed in this report refer to plant remains preserved by charring/carbonization. Initially, samples of up to approximately 40 liters were taken from selected sealed features/units, but it was quickly decided to sub-sample that material

and process a maximum of 5 liters from each unit as there were plentiful charred plant remains in almost all samples tested.

During the season 31 features were sampled. The material was processed by bucket flotation using a 300µm mesh and all material was air-dried, then examined under a low resolution, x7-15 magnification binocular microscope. Specimens were identified to species where possible, based on diagnostic morphological characteristics. Most were identifiable only to genus, tribe or family. After just one season it is too early to undertake any detailed analysis of the material from the site, but a few preliminary observations can be made and general conclusions can be drawn.

Table 1 lists the number of samples taken from the five areas of investigation [Table 1]. With the exception of Area 3, all dating information is generalized to New Kingdom or Third Intermediate Period. Raw data counts of identified items by period and area, and the density of items per liter are provided in tabular form [Tables 2, 3]. It is immediately clear that the New Kingdom samples were richer (in total nine samples, 8290 items and an average of 192.8 items per liter) than the Third Intermediate Period samples (18 samples, about 6500 items and average of 70 items per liter), and that Area 4, the western side of the site (all New Kingdom samples) was by far the richest area in terms of quantities of material. However, in terms of diversity of plant species present [Figs 14, 15], the Third Intermediate Period samples were far richer. The higher taxa diversity for the Third Intermediate Period samples is perhaps what would be expected for this period (Fahmy 1997), and it is possible that the larger number of samples taken from

Area 3 could be responsible for the wider variety of species from that area.

An overview of the most commonly occurring species/plant groups is provided in Table 4. The presence of Viciae (vetch/pea) tribe of legumes in over 30% of the samples (*Lathyrus* sp., *Vicia* sp., *Lens* sp.) is unsurprising as these plants were cultivated for human consumption, possibly for animal consumption and, along with *Rumex* sp. were present as a crop weed throughout Egyptian history (Fahmy 1997). The relatively high numbers of Cyperaceae family seeds, in particular *Scirpus* spp. (Club rush) and other wet-loving species is of interest. In future seasons, once more samples have been analyzed, it may be possible to detect some localized small-scale ecological changes.

A slightly closer look at the ratios of cereal grains : cereal chaff : wild grasses for the site — 1 : 5.5 : 3.6 — shows the clear

Table 1. Number of samples from the five areas of investigation

Area	Period	Number of samples
1	Third Intermediate Period	1
2	Third Intermediate Period	1
3	Eighteenth Dynasty	2
3	Eighteenth–Nineteenth Dynasty	1
3	New Kingdom–Third Intermediate Period	4
3	Third Intermediate Period	12
4	New Kingdom	6
5	Third Intermediate Period	4
Total		31

Table 2. Raw data counts of identified items by period and the density of items per liter

Period	Number of samples	Total number of items	Total sample volume (l)	Density of items per liter of soil
Eighteenth Dynasty	2	1252	8	156.50
Eighteenth–Nineteenth Dynasty	1	15	5	3.00
New Kingdom	6	7023	30	234.10
New Kingdom–Third Intermediate Period	4	193	20	9.65
Third Intermediate Period	18	6596	90	70.91
Total	31	15,079	153	98.55

Table 3. Raw data counts of identified items by area and the density of items per liter

Area	Number of samples	Total number of items	Total sample volume (l)	Density of items per liter of soil
1	1	137	5	27.70
2	1	409	5	81.80
3	19	3120	93	33.55
4	6	7023	30	234.10
5	4	4390	20	219.50
Total	31	15,079	153	98.55

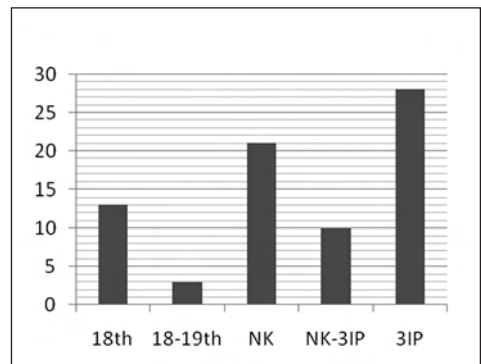
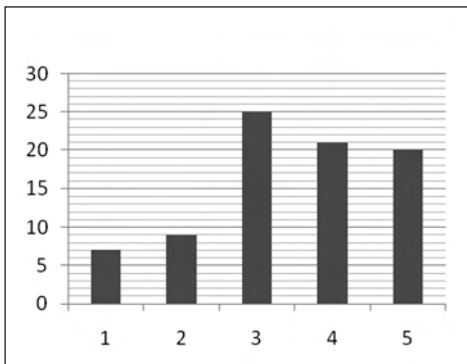

Fig. 14. Taxa diversity by area

Fig. 15. Taxa diversity by period

dominance of cereal chaff (predominantly *Triticum dicoccum* Emmer wheat) and wild grasses (mainly Rye grass *Lolium* sp. with some Canary grass *Phalaris* sp.), with small numbers of cereal grains. Charcoal (wood species as yet unidentified) was present in most samples. This very clearly indicates that most plant remains at the site are waste products of cereal processing used as a fuel supplement to wood or as fodder which becomes dung to be used subsequently as fuel (see Murray 2000; 2009; van der Veen 1999). This suggests that other plant species present in these samples (e.g. specimens of Boraginaceae, Caryophyllaceae, Asteraceae and Chenopodiaceae families) were all cereal crop weeds.

Although there is not a great amount of other published data to consult, a comparison between the New Kingdom samples from Tell el-Retaba and those from New Kingdom Memphis is possible. It is immediately apparent that the average of 47.1 items of cereal chaff per liter and

Table 4. Most commonly occurring species/plant groups

Taxa occurring in over 25% of the samples	%
Cyperaceae (Sedge/reeds)	25.80%
<i>Rumex</i> sp. (Dock/sorrel)	25.80%
Viciae tribe (Pea/vetch)	32.25%
<i>Lens</i> sp. (Lentils)	35.48%
Root/Tuber	41.93%
<i>Phalaris</i> sp. (Canary Grass)	45.16%
Dung fragments	51.61%
<i>Ficus carica</i> (Common fig)	51.61%
<i>Hordeum sativum</i> grain (Barley)	58.06%
<i>Triticum dicoccum</i> grain (Emmer wheat)	61.29%
<i>Scirpus</i> spp. (Club rush)	80.64%
Trifoliae tribe (Clover)	83.87%
<i>Lolium</i> sp. (Rye grass)	100%
<i>Triticum dicoccum</i> chaff	100%

Table 5. Count of items (#), count as a percentage of the total (%) and items per liter for the New Kingdom material

New Kingdom samples Taxa group	Total: 8483 items / 63 liters		Average items per liter
	#	%	
Cereal chaff	2970	35.0	47.1
Cereal grain	499	5.9	7.9
Dung fragments	158	1.9	2.5
Potential fodder plants	1099	13.0	17.4
Wild grasses	2677	31.6	42.5
Other weed species	64	0.8	1.0
Wet-loving species	876	10.3	13.9
Other	140	1.7	2.2

13.9 items of wet-loving species from New Kingdom Tell el-Retaba far exceed the average of one item of chaff and 0.2 items of wet-loving species per liter in New Kingdom Memphis. However, the average of 42.5 items per liter of wild grasses at Tell el-Retaba is easily comparable to the 50 items per liter at Memphis (based on *Table 5* in this report and *Table 26.1* in Murray 2009). The significance of this will need to be examined once more material has been analyzed in future seasons.

In addition to the charred waste products of cereal processing, the samples contained some other species that can indicate other activities on site. The presence of *Linum usitatissimum* Linen/Flax seeds backs up the artefactual evidence for linen production on the site (loom weights, bone spatulas, spindle

whorls). *Ficus carica* (Fig) was present in small numbers in just over 50% of the samples (all areas and dates), and *Vitis vinifera* (Grape) was present in three Third Intermediate Period samples from Area 5 and one New Kingdom sample from Area 4. It has long been established that the Delta was the prime vineyard area of Egypt. The soils in the region are far better suited to grape cultivation and there is ample textual evidence which attests to the many estates cultivating grapes in the Delta region.

Overall, Tell el-Retaba has exceptionally well preserved charred plant remains. In future seasons further archaeobotanical work has the potential to add greatly to our knowledge about this site, and the corpus of knowledge of the use of plants in ancient Egypt.

Dr. Sławomir Rzepka
Institute of Archaeology, University of Warsaw
00-927 Warsaw, Poland
ul. Krakowskie Przedmieście 26/28
s.rzepka@wp.pl

Dr. Jozef Hudec
Agyptos Foundation
Safárikova 63
953 03 Zlate Moravce, Slovakia
Jozef.Hudec@savba.sk

Claire Malleson
University of Liverpool
mally@liverpool.ac.uk

REFERENCES

- Aston, D.A.
 1997 The pottery [in:] G.T. Martin, *The Tomb of Tia and Tia. A Royal Monument of the Ramesside Period in the Memphite Necropolis* [=EES Excavation Memoir 58], London: Egypt Exploration Society, 82–103
 2004 Amphorae in New Kingdom Egypt, *Ägypten und Levante* 14, 175–213
- Fahmy, A.G.
 1997 Evaluation of the weed flora of Egypt from Predynastic to Graeco-Roman times, *Vegetation History and Archaeobotany* 6/4, 241–247
- Górka, K., Rzepka, S.
 2011 Infant burials or infant sacrifices? New discoveries from Tell el-Retaba, *MDAIK* 67, 99–107
- Hope, C.A.
 1989 Amphorae of the New Kingdom [in:] C.A. Hope (ed.), *Pottery of the Egyptian New Kingdom. Three Studies*, Burwood: Victoria College Press, 87–118
- Murray, M.A.
 2000 Cereal production and processing [in:] P.T. Nicholson, I. Shaw (eds), *Ancient Egyptian Materials and Technology*, Cambridge: Cambridge University Press, 505–536
 2009 Questions of continuity: Fodder and fuel use in Bronze Age Egypt [in:] A. Fairbairn, E. Weiss (eds), *From Foragers to Farmers. Papers in Honour of Gordon C. Hillman*, Oxford: Oxbow Books, 254–267
- Petrie, W.M.F., Duncan, J.G.
 1906 *Hyksos and Israelite Cities*, London: British School of Archaeology in Egypt
- Rzepka, S., Wodzińska, A., Malleon, C., Hudec, J., Jarmużek, Ł., Misiewicz, K., Malkowski, W., Bogacki, M.
 Forthcoming New Kingdom and Third Intermediate Period in Tell el-Retaba, *Ägypten und Levante* 21, in press
- (van der) Veen, M.
 1999 The economic value of chaff and straw in arid and temperate zones, *Vegetation History and Archaeobotany* 8/3, 211–224
- Wodzińska, A.
 2012 Tell el-Retaba 2009: the pottery, *PAM* 21 (*Research 2009*), 124–133