

Eleonora Carminati

Jewellery Manufacture in the Kura-Araxes and Bedeni Cultures of the Southern Caucasus : Analogies and Distinctions for the Reconstruction of a Cultural Changeover

Polish Archaeology in the Mediterranean 23/2, 161-186

2014

Artykuł został opracowany do udostępnienia w internecie przez Muzeum Historii Polski w ramach prac podejmowanych na rzecz zapewnienia otwartego, powszechnego i trwałego dostępu do polskiego dorobku naukowego i kulturalnego. Artykuł jest umieszczony w kolekcji cyfrowej bazhum.muzhp.pl, gromadzącej zawartość polskich czasopism humanistycznych i społecznych.

Tekst jest udostępniony do wykorzystania w ramach dozwolonego użytku.

JEWELLERY MANUFACTURE IN THE KURA-ARAXES AND BEDENI CULTURES OF THE SOUTHERN CAUCASUS: ANALOGIES AND DISTINCTIONS FOR THE RECONSTRUCTION OF A CULTURAL CHANGEOVER

Eleonora Carminati

Faculty of Arts, School of Historical and Philosophical Studies, University of Melbourne

Abstract: Jewellery manufacture by the Kura-Araxes and Bedeni cultures of the Late Chalcolithic–Early Bronze Age (mid 4th/3rd millennium BC) in the southern Caucasus is defined through several analogies as well as differences. Kura-Araxes jewellery is rather modest in production, usually made of copper or arsenical copper alloy. It is found in burials of an egalitarian-based society. The transition to the Bedeni phase is characterized by major innovations, illustrating marked cultural discontinuity: jewellery is frequently made of precious metals and occurs in wealthy burials that can be associated with apparent leaders of the community. Jewellery assemblages are rich and the working of some pieces so remarkable that they are veritable works of art. At the same time new techniques, probably acquired from the south (Mesopotamia and Anatolia), were introduced. This analysis will provide a different insight into this transitional phase, concentrating on the parallels and differences in shape, technology, use and selection of materials and artisan skills for the manufacture of jewellery. Consequently, some of the main social and economic settings of the Kura-Araxes and Bedeni cultures will be examined and compared.

Keywords: jewellery, manufacture, southern Caucasus, Early Bronze Age, Bedeni, Kura-Araxes

New cultural and social trends in the southern Caucasus from the end of the Chalcolithic and through the early Bronze Age coincided with the transition from the Kura-Araxes culture (about mid 4th/mid 3rd millennium BC) to the Bedeni culture

(mid 3rd/end of 3rd millennium BC).¹ The commonly accepted date for the changeover is the mid-3rd millennium BC (about 2600 BC), following a tentative period of coexistence between the two groups [*Fig. 1*]. Fieldwork and research

¹ For an overview of the chronology of the Kura-Araxes and the Early Kurgan phases of which the Bedeni culture is the final stage, see Edens 1995: 54–60; Kushnareva 1997: 43–54, 81–84; Marro, Hauptmann (eds) 2000: *passim*; Sagona 2004: 478–479; Lyonnet 2007: 13; Palumbi 2008: 327.

	Southern Caucasus		Eastern Anatolia		Upper Euphrates
			Sos Höyük	Arslantepe	
2000	Bedeni Martqopi/ Early Trialeti	Kura-Araxes III Kura-Araxes II Kura-Araxes I Proto Kura-Araxes	EB I EB II Late Chalcolithic	VI D VI C VI B1 - VI B2 VI A VII VIII	EJ V
2100					EJ IV
2200					EJ III-I
2300					LC 5 or Late Uruk
2400					LC 4
2500					LC 3
2600					LC 2
2700					LC 1
2800					
2900					
3000					
3100					
3200					
3300					
3400					
3500					
3600					
3700					
3800					
3900					
4000					

Fig. 1. Cultural periodization of the regions considered in the text
(After Lyonnet 2007: 13; Palumbi 2008: 327)

in recent years² have focused on the two cultural phenomena separately, though seldom considering the transitional phase. The major economic, political, cultural and social trends and innovations, which marked the historical changeover, have yet to be studied in detail.

The present paper examines the issue through jewellery, which is one of the most significant and relevant classes of artifacts, not only because of its formal characteristics but also because of its intrinsic relevance. Research in the past has concentrated on the materials used, applying an aesthetic approach to the

study of artisanship mainly because of the rarity of the finds. By grouping these finds, the present study aims first to describe and classify jewellery morphology, and then to define the processes involved in the development of manufacturing techniques. It will seek to analyze the combination of traditional and innovative features with outside influence and will examine other important issues, such as ownership and display of jewellery within a community, indirectly highlighting economic substructures and comparing the political and social settings of these phases.

THE KURA-ARAXES PHASE

The emergence and development of the Kura-Araxes culture in the southern Caucasus is dated to about the mid-4th millennium BC, following major economic and social transformations attested in the region since the end of the Neolithic and beginning of the Chalcolithic (Sagona 1984; Kushnareva 1997: 43; Palumbi 2009).³ Soon after the initial development of this cultural group, many of its features spread beyond its cradle, which was originally believed to lie between the Kura and Araxes rivers (Kuftin 1941:

114) [*Fig. 2*].⁴ Sites of the Kura-Araxes group and other culturally related sites from the early 3rd millennium BC were discovered throughout Transcaucasia (Georgia, Armenia and Azerbaijan), Anatolia, the Iranian Azerbaijan and as far as the southern Levant in the region of Tel Bet Yerah (Greenberg 2007: 257–261).⁵ This was one of the earliest and largest cultural phenomena attested in the ancient Near East. Expansion of the culture peaked during its apogee in the Late Chalcolithic and first half of the Early Bronze Age

² Interesting analyses of this transitional phase have been published by Edens (1995) and more recently by Sagona (2004). On the rescue excavations conducted during the construction of the Baku–Tbilisi–Ceyhan pipeline, see Gamkrelidze, Vickers (eds) 2010; on the research carried out at the kurgans of Okherakhevi and the preliminary report on the excavations at the settlement of Khashuri Natsargora (Georgia), see Rova, Puturidze, Makharadze 2011; Puturidze, Rova (eds) 2012.

³ The recent discovery of Red and Black Burnished Ware at the site of Ovcular Tepesi in Nakhchivan (Azerbaijan), associated with a Late Chalcolithic horizon, raises new issues concerning the emergence of the Kura-Araxes culture (Marro, Bakhshaliyev, Ashurov 2011: 66–69).

⁴ For recent discussion of the roots of the Kura-Araxes culture, see Kiguradze, Sagona 2003: 38–94; Palumbi 2008: 12.

⁵ A counterpart of the Kura-Araxes culture in the southern Levant was the more commonly known Khirbet Kerak Culture, called so after the site of Tel Bet Yerah (Khirbet Kerak), located on the southwestern shore of Sea of Galilee, where W.F. Albright first distinguished this pottery group (Amiran 1952: 90). The Anatolian and Transcaucasian affiliation of this culture throughout North Syria was clear from the start (Amiran 1952; 1965).

(phases II and III, see Sagona 1984: 97–103; Kushnareva 1997: 44–54; Palumbi 2008: 12–16), dated to the end of the 4th–beginning of the 3rd millennium BC.

Kura-Araxes archaeological sites, classified as settlements and cemeteries, were discovered in different geographic locations, including plains, river valleys and highland pastures (Palumbi 2007: 21), demonstrating the skills of Kura-Araxes communities in adapting and modifying

their lifestyle and customs to different ecological niches. Settlements in this phase grew more rapidly compared to the earlier Neolithic and Chalcolithic periods, possibly due to demographic pressure or new migration waves (Kushnareva 1997: 43; Palumbi 2009: 129). But there are several other related features (the so-called ‘push-and-pull’ factors),⁶ which should be considered in any interpretation of this issue.

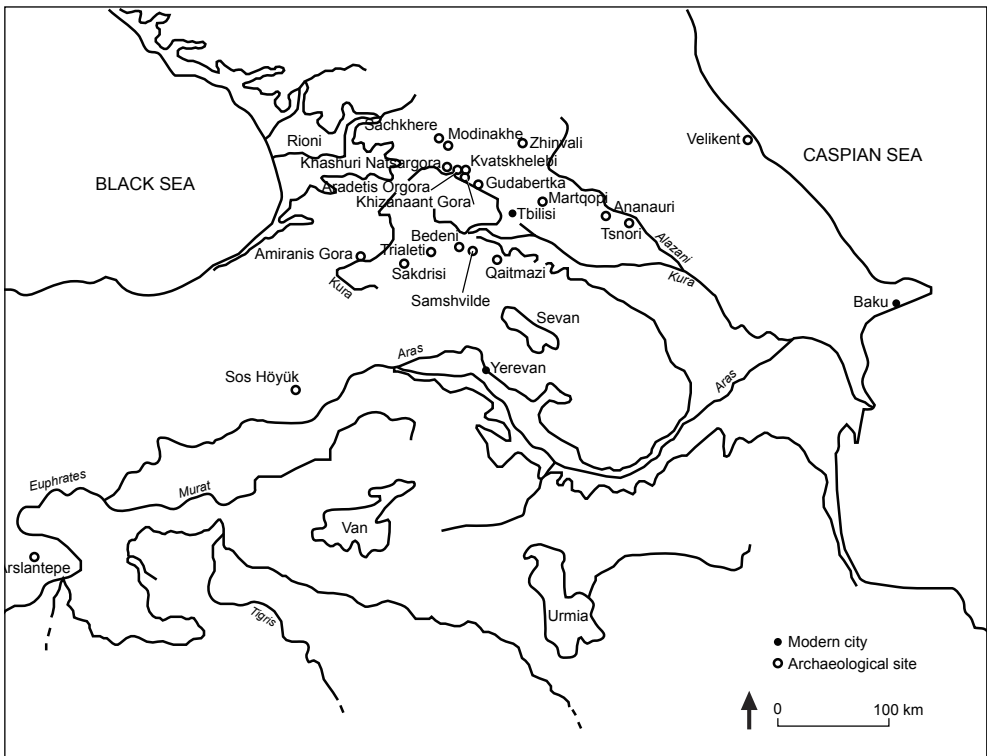

Fig. 2. Map of the southern Caucasus with approximate location of sites mentioned in the text (Adapted from Lyonnet 2000: 313, Fig. 1)

⁶ Rather than the result of one or two single elements, the expansion of the Kura-Araxes culture should be considered as a convergence of different but related elements. In this phase, new economic factors associated with a complete change in lifestyle (e.g., development of new interregional routes, trade in raw materials, and search for new pastures) could explain this phenomenon in part, this being related to other deeply-rooted features as well (Palumbi 2009: 129 and cited literature).

Several emblematic traits of the Kura-Araxes culture are readily identified in settlement architecture and cemetery structure, but primarily in the material culture.⁷ Pottery is the most representative class of finds, present throughout the Kura-Araxes expansion area. Monochrome and

Red-Black Burnished ware are commonly attested at all Kura-Araxes sites.⁸ Shared features were detected also in everyday tools, metal objects and jewellery. Jewellery manufacture is rather modest in this phase, but an analysis of this assemblage can contribute significant data.

THE KURA-ARAXES JEWELLERY COLLECTION

Kura-Araxes jewellery is usually discovered in burial contexts, rarely in settlements, and it is an integral part of grave assemblages. Burial assemblages are mostly made up of medium to large sets of standardised pottery vessels, everyday tools, and sporadic metal objects, such as weapons (Palumbi 2007: 21). Similarities in grave good inventories have been detected throughout the Transcaucasian region, mainly between the southern Caucasus and Anatolia.

A classification and grouping of Kura-Araxes (and later also of Bedeni) jewellery into morphological classes can help in the systematisation of inventories. Typological analysis permits the identification of related features, such as technology and raw materials employed in the production of jewellery, as well as an evaluation of its use as a social *status symbol*. In this analysis, finds will be considered only in a broad geographical perspective, attesting the presence or absence of each class in the macro-regions (Transcaucasia, Anatolia, northern and western Caucasus, eastern Mediterranean, Mesopotamia, Levant, etc., see Gambashidze *et alii* 2001; 2010; Miron,

Orthmann [eds] 1995 and archaeological site reports).

Representing a typical Kura-Araxes jewellery inventory are pins manufactured in different ways and thus divided into several types and subtypes (double-spiral-headed, T-shaped, and loop-headed pins), spiral-shaped ornaments (rings, hair-rings, and spiral bracelets), pendants, beads and diadems. These classes will be now assessed in detail, considering the formal features and areas/periods of manufacture and distribution of the finds.

CLASS A: PINS

A.1 Double-spiral-headed pins

This pin type is one of the most emblematic and traditional groups of pins manufactured during the Kura-Araxes period. Double-spiral-headed pins (alternatively called double-voluted) can be divided into several subtypes on the basis of their morphology, as already outlined by Gambashidze (Gambashidze *et alii* 2010: 188, Pl. 16). Generally they are characterised by flattened, triangular or rounded heads with volutes starting

⁷ For a general overview, see Lordkipanidze 1991: 43–54; Edens 1995: 54; Kushnareva 1997: 74–78; Gambashidze *et alii* 2001: 95–101; Palumbi 2007; 2009.

⁸ For a complete and comprehensive analysis of Kura-Araxes pottery manufacture, see the pioneering work of A. Sagona (1984) and the study by G. Palumbi (2008).

from the upper or lower angles and very thin, straight shafts [Fig. 3]. Thin metal wires were rolled in a variable number of coils to create the two symmetrical volutes. **Subtype A.1.1** (Gambashidze group I-a) is characterised by a rounded head with low volutes, **subtype A.1.2** (Gambashidze group I-b) has a triangular head with high volutes, and **subtype A.1.3** (Gambashidze group I-c) has a V-shaped head and high volutes, made of one to four coils. The four-spiral-headed pins (**subtype A.1.4**) are a variant of the type with two sets of double-spirals of subtype A.1.3, one above the other, forming the head. Pins of this kind were found, for example, at the site of

Arslantepi in eastern Turkey (Frangipane *et alii* 2001: 117, Fig. 19:19–20).

Double-spiral-headed pins are attested in the southern Caucasus mainly from late 4th to 3rd millennium BC (Kura-Araxes II and III phases; Gambashidze *et alii* 2010: 182, 188), but similar pins were also found in contemporary contexts in the Upper Euphrates region, in central and eastern Anatolia (Palumbi 2008: 128–129, Fig. 4.19) and in Iran (Gambashidze *et alii* 2001: 256, Fig. 45). These pins appear to have been very common throughout the Near East, where they were manufactured for centuries (Huot 1969; Sagona 1981), and in later contexts in the northern Caucasus, dated to the 3rd millennium BC (Palumbi 2008: 129).

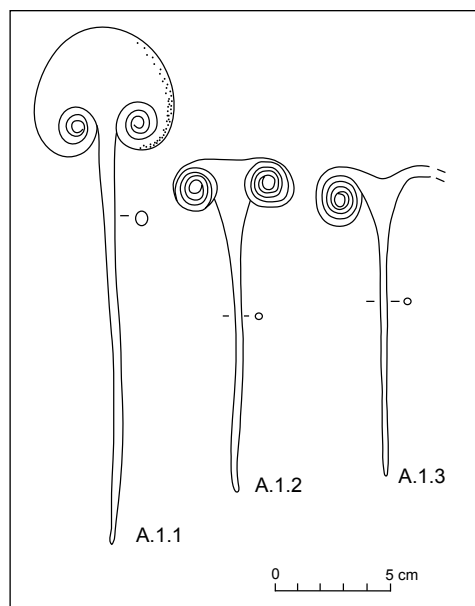

Fig. 3. *Kura-Araxes double-spiral-headed pins: subtypes A.1.1, Quaitmazi (After Gambashidze et alii 2010: Pl. 14, No. 222); A.1.2, Khashuri Natsargora (After Puturidze, Rova [eds] 2012: 145, Fig. 7, No. 3); A.1.3, Samsvilde (Gambashidze et alii 2010: Pl. 4, No. 65)*

A.2 T-shaped pins

Pins representing Gambashidze group III have a T-shaped head with thickened edges and a pierced or partly rolled shaft in the upper segment [Fig. 4] (Gambashidze *et alii* 2001: 257, Fig. 48; 2010: 190, Pl. 18). **Subtype A.2.1** is the most common, with two rounded edges, and the shaft rolled in the upper part, **subtype A.2.2** has a pierced shaft rolled in the upper part and **subtype A.2.3** has a pierced shaft, which is not rolled.

The typical rounded finials, placed at the end of the head, could have been manufactured in different ways: as full circles or sometimes as spoke wheels (Miron, Orthmann [eds] 1995: 58, Fig. 34). The head of one unusual piece found at Sachkhere (**subtype A.2.4**) is made up of two contiguous spoke wheels, which are rotated at right angles compared to the ones of other T-shaped pins [Fig. 4, far right] (D'Acchille 2011: 70). The head of the T-shaped pins resembles the wheels

of double-wheeled wagons, the first occurrences of which date to this phase and can thus be associated with this first evidence (Mirtskhulava 2011: 42).

T-shaped pins were manufactured from the end of the Kura-Araxes culture (phase III), initially only at the site of Sachkhere in Imereti (Georgia). Contrary to double-spiral-headed pins, this type has been attested mainly at the sites of Sachkhere and Nacherqzevi in Imereti and in Kvatskhelebi Level B in Shida Kartli (Kushnareva 1997: 60, Fig. 22). No similar specimens are known from outside

the southern Caucasus and they can be considered as an original, local production (Miron, Orthmann [eds] 1995: 223, Fig. 49).

A.3 Loop-headed pins (*Schleifennadeln*)

Loop-headed pins, also known as “Schleifennadeln”, are pins made of two metal wires, one rolled around the upper part of the other (Gambashidze groups IV–VII; Gambashidze *et alii* 2010: 191, Pl. 19) [Fig. 5]. The head of these pins, formed of rolled wire, usually ends in a loop and there is a biconical element

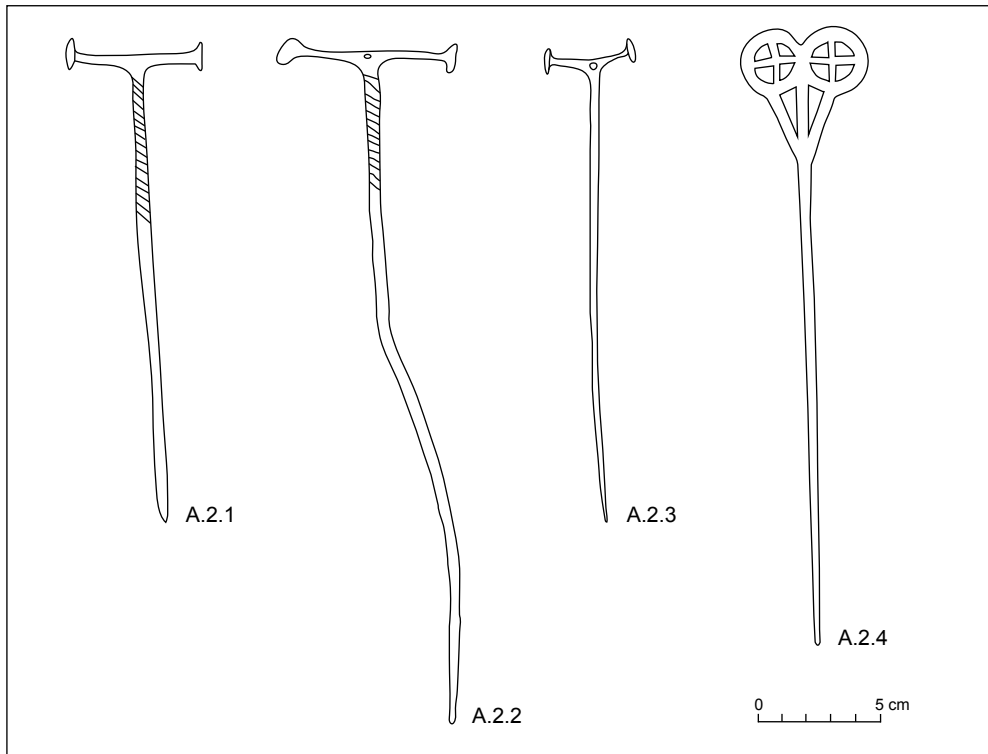

Fig.4. T-shaped pins: subtypes A.2.1, Sachkhere-Tsartsis Gora (After Gambashidze *et alii* 2010: 536, Pl. 26, No. 437); A.2.2, Koreti-Pasieti (After Gambashidze *et alii* 2010: 530, Pl. 20, No. 321); A.2.3, Sachkhere-Tsartsis Gora (After Gambashidze *et alii* 2010: 536, Pl. 26, No. 436); A.2.4 (spoke-wheel-headed), Sachkhere (After D'Acchille 2011: 70)

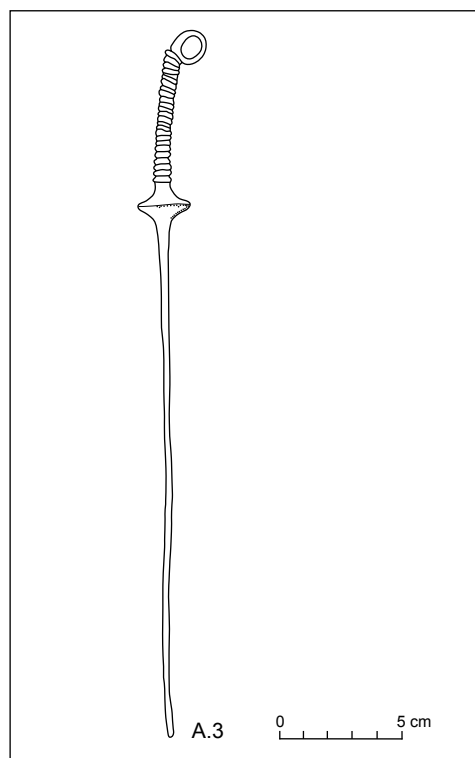

Fig. 5. Loop-headed pin (type A.3), Sachkhere (Bertram 2002: 816, Fig. 1, No. 9)

in the upper part of the thin shaft, which is usually long and sharp, although some examples have a flattened end (e.g., from Sachkhere, Miron, Orthmann [eds] 1995: 223, Fig. 48).

Loop-headed pins were manufactured for the first time during the final stages of the Kura-Araxes culture (phase III). They were attested first at Sachkhere and in nearby areas of Imereti and later also at sites located along the Caspian Sea (e.g., Velikent in Dagestan; Bertram 2002: 826) and in Upper Mesopotamia.⁹

CLASS B: SPIRAL-SHAPED ORNAMENTS

B.1 Rings

Rings (subtype B.1) manufactured during the Kura-Araxes phase were thick, ductile metal bands with rounded cross-sections. They measured approximately 1.4 cm to 2 cm in diameter, and were usually shaped as one coil with pointed ends [Fig. 6, extreme left]. They were mostly made of arsenical copper and seldom of lead (exclusive find from Amiranis Gora, Gambashidze *et alii* 2001: 249, Fig. 27). Rings are often found in Kura-Araxes inventories mainly from the southern Caucasus, and they can be considered as an emblematic jewellery class of the period, since no clear occurrence of them is attested in later contexts (Gambashidze *et alii* 2001: 248, Figs 23–24; 255, Fig. 42).

B.2 Spirals or hair-rings

Very similar in shape, metal spirals (subtype B.2) differed from rings only in the number of coils. They had two to a maximum of four coils with rounded cross-sections, sometimes with a slightly flattened inner side, and sharp ends [Fig. 6, center left]. The function of these objects is still unclear: they could have been used as ear- or finger-rings or, as Woolley already suggested in the previous century, as hair ornaments (see Pittman 1998: 108). At Ur these spirals were found on the skulls and the upper shoulders.

Spirals from the Kura-Araxes phase were made usually of arsenical copper and only exceptionally of silver and gold, e.g., ornaments interpreted as hair-rings from Arslantepe (Frangipane *et alii* 2001:

⁹ A loop-headed pin from Tell Ta'yinat in the plain of Antioch may have been imported from the Caucasus (Miron, Orthmann [eds] 1995: 223, Fig. 48).

108–109). This jewellery type has been widely attested from the end of the 4th and the beginning of the 3rd millennium BC (Kura-Araxes phases II and III) in the southern Caucasus, Anatolia and Mesopotamia. The extensive diffusion of this class of jewellery makes identifying its origin difficult at best and compromises efforts to specify a date for individual items. Moreover, hair-rings were found during the Middle Bronze Age in the Caucasus region, in the eastern Mediterranean and throughout the ancient Near East (Gambashidze *et alii* 2001: 265, Fig. 74).

B.3 Bracelets

Spiral bracelets — Gambashidze group I — may also be included in this jewellery group (Gambashidze *et alii* 2010: 206, Pl. 23). This type (subtype B.3.1) is made

of thin metal sheet and measures 4–7 cm in diameter. The metal is turned into one and a half to four flattened coils, usually with triangular cross-section (Gambashidze *et alii* 2001: 254 Fig. 40, 256 Fig. 44) [Fig. 6, right]. Considering its occurrence, spiral bracelets can be more accurately attributed to Kura-Araxes phases II and III (Gambashidze *et alii* 2010: 207, Nos 417, 584, 646, 762, 773).¹⁰ This type of jewellery is considered a typical Kura-Araxes production, since it does not occur in the area in later times.

CLASS C: PECTORALS AND PENDANTS

Anchor-shaped pendants (subtype C.1) represent another exclusive Kura-Araxes jewellery type. These ornaments were small (about 1.8–3.0 cm) with rounded edges

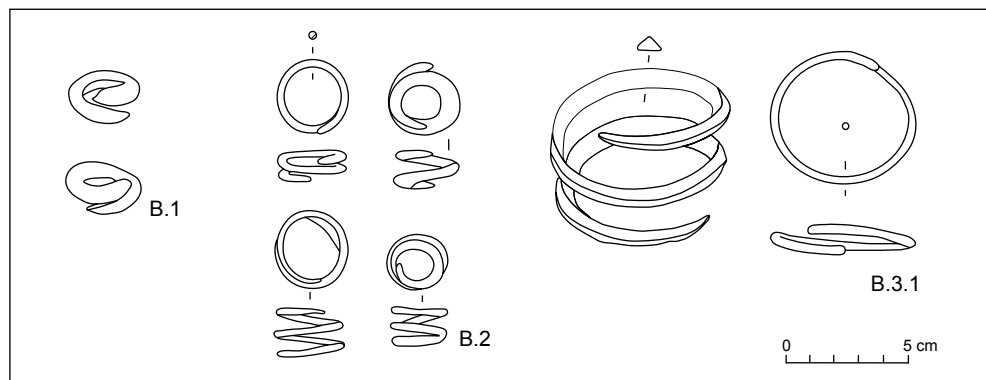

Fig. 6. Spiral jewellery: subtype B.1, rings – top, arsenical-copper, Khashuri Natsargora and bottom, lead, Amirani Gora (after Gambashidze *et alii* 2001: 255 and 248, Nos 42 and 23 respectively); subtype B.2, spirals or hair-rings – three from Arslantepe (after Frangipane *et alii* 2001: 117, Fig. 19, Nos 14, 17, 22) and one from Aradetis Orgora (After Gambashidze *et alii* 2010: 211, Pls 25, 168); subtype B.3.1, bracelets – Khashuri Natsargora (Puturidze, Rova [eds] 2012: 143, Fig. 5, No. 7) and Arslantepe (after Frangipane *et alii* 2001: 117, Fig. 19, No. 11)

¹⁰ Similar spiral bracelets were also found in the northern Caucasus in later contexts, dated to about the 5th–4th centuries BC; a gold exemplar with multiple coils was found in a kurgan from the 4th century BC at Maikop (Leskov 2008: 63, No. 80).

and a pierced hole in the upper part. Their shape resembled the anchor types [Fig. 7] (Gambashidze *et alii* 2010: 195). Anchor-shaped pendants were manufactured from

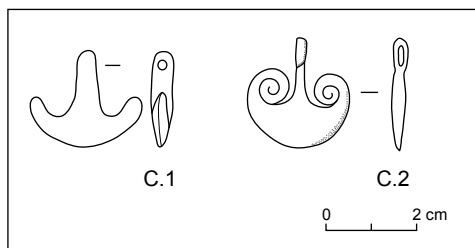

Fig. 7. Pendants: subtype C.1, anchor-shaped – *Amiranis Gora* (After Gambashidze *et alii* 2010: 524, Fig. 14, No. 213); subtype C.2, double-volute – *Aradetis Orgora* (After Gambashidze *et alii* 2010: 528, Pl. 18, No. 269)

the beginning of the 3rd millennium BC in the southern Caucasus (Kura-Araxes phases II and III), but they were not attested in subsequent periods in the area (Gambashidze *et alii* 2001: 251, Fig. 31).

Double-volute pendants (subtype C.2) from Kura-Araxes contexts were a stylized variant of the anchor-shaped ones, differing specifically in their orientation. The heads were identical with subtype A.1.1 [see Fig. 4, right] and were also attested in later periods (see below, subtype A.4 [Fig. 10]).

CLASS D: BEADS

Beads are a very frequent and common class of finds in archaeological Kura-Araxes contexts from the southern Caucasus. They can be of different shape and size, made either of metal or other materials, such as

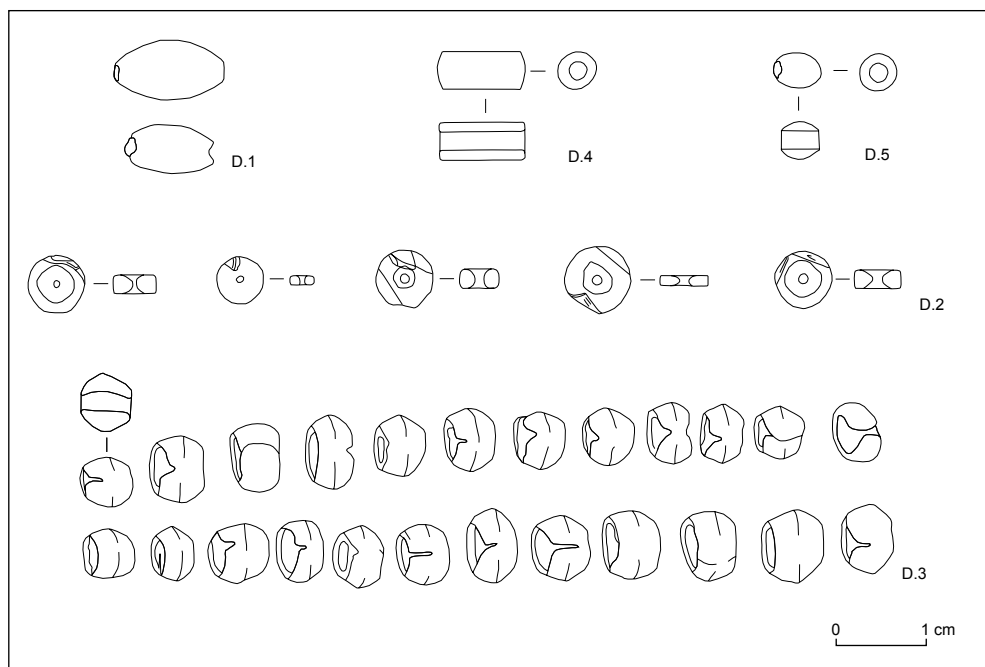

Fig. 8. Beads of different types, *Khashuri Natsargora* (After Puturidze, *Rova* [eds] 2012: 145, Fig. 7, Nos 6, 7, 10, 11)

semiprecious stones, obsidian, bone and frit/faience.¹¹ Types include barrel- or disc-shaped examples (subtypes D.1 and D.2), biconical (subtype D.3), cylindrical (subtype D.4) and rounded beads (subtype D.5) (types after Beck 1928: 1–76). They were usually found strung together as bracelets or necklaces [Fig. 8, top] (Gambashidze *et alii* 2001: 250, 255) in burials and settlements (from between the end of the 4th and the beginning of the 3rd millennium BC). Beads continued to be manufactured without break throughout the 3rd millennium BC and later, presenting almost the same features and similar materials.

CLASS E: DIADEMS

Diadems made of beaten thin metal sheet with semi-circular ends and outer surfaces that were either plain or decorated were one of the most typical and significant Kura-Araxes jewellery groups. One example was discovered in Grave 2 at Kvatskhelebi Level C (Glonti *et alii* 2008: 157), two others come from Gudabertka (Gambashidze *et alii* 2010: 224, Pl. 31). In a recent paper on the Kura-Araxes diadems, G. Mindiashvili inferred that the latter diadems were found not in a grave as expected, but below the floor of

a house in the settlement; in the absence of a precise recording of the context of these finds, the attribution of the diadems remains uncertain (see Mindiashvili 2012: 4–11). Another two diadems came from Arslantepe (Frangipane *et alii* 2001: 109–111).

The Kvatskhelebi diadem of beaten copper is one of the finest [Fig. 9]. It was provided with three rivet holes at the ends, probably for interlacing a wire to hold the diadem around the head, and three rows of cut ornaments, both geometric and zoomorphic in style, on the outer surface. At Arslantepe, diadems were associated with burials in graves H-223 and H-224 and in the latter grave, the ornament was still in place around the skull (Frangipane *et alii* 2001: 126–128).

Diadems from burial contexts were associated with important members of the community. They seem to have been the only distinctive class of jewellery found in Kura-Araxes graves that could be considered as denoting social rank. Their importance is certainly reflected in the care invested in their manufacture, indicating their role as *status symbols*. Moreover, diadems were the only class of artifacts in the Kura-Araxes repertoire to be decorated with zoomorphic motifs.

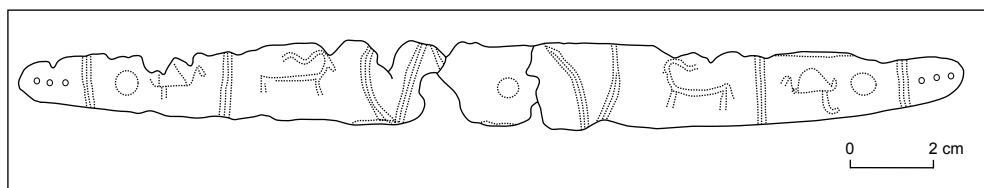

Fig. 9. Diadem, Kvatskhelebi
(After Gambashidze *et alii* 2010: 224, Pl. 31, No. 116)

¹¹ Distinguishing between faience and frit without appropriate technological studies and laboratory analyses can be very difficult. For a detailed description of these materials, see Moorey 1994: 167.

RAW MATERIALS AND MANUFACTURING TECHNIQUES

Kura-Araxes jewellery was commonly made of metal, primarily copper or arsenical copper alloy (see Gambashidze *et alii* 2001: 80). The concentration of arsenic in these objects varies from 1% to 10% and in the southern Caucasus it was probably either found as a natural alloy or intentionally added (Chernykh *et alii* 1991). Copper and arsenical copper alloy were generally used for the manufacture of everyday tools and weapons. Excluding a few occasional finds and the unique case of the Arslantepe “royal tomb”, which produced some golden hair-rings and beads (Horizon VI B2, 2900–2800 BC; Frangipane *et alii* 2001: 106–107), there is no evidence of a gold or silver manufacturing tradition during the Kura-Araxes period in the southern Caucasus. Golden objects are virtually unknown despite gold mining possibly being undertaken in the Kura-Araxes phase, as suggested by the discovery (by the Deutsches Bergbau-Museum of Bochum) of a gold mining site from the 4th millennium BC in the Sakdrisi area in southern Georgia (Stöllner *et alii* 2010).¹² This suggests either that gold was locally mined and exported as a raw material or, alternatively, that ready objects were recast or were deliberately left out of the graves. In the latter case, which is frequently assumed, it would reflect a situation in which there were no clear social distinctions in the burials (except for the diadems perhaps). This would constitute tangible evidence of a society founded around the concept of equality.

Hot or cold forging and casting, which are among the oldest known metallurgical techniques in the region, were used the most often for the manufacture of metal jewellery. These techniques were relatively quick and easy to apply and offered accuracy in finishing items, assuring some uniformity of shape — traits characteristic of the main morphological groups described above. The gradual development and use of these artisan techniques rapidly changed both the jewellery manufacturing process, which became faster and simpler, and the jewellery itself, resulting in more standardised items.

The Kura-Araxes jewellery collection also reveals evidence of the use of semi-precious stones, such as carnelian and rock crystal, as well as obsidian, frit/faience, limestone and bone. These materials were employed mainly for the manufacture of beads, whereas metals were favoured (and more suitable) for other classes of jewellery. A recent study has revealed carnelian primary and secondary deposits in the Armenian and Nagorno-Karabakh regions, suggesting the local manufacture and circulation of this type of beads (Brunet 2009: 61 and 65); obsidian was mainly quarried in the Chikiani volcano district of southern Georgia but was only occasionally used to make beads (Badalyan *et alii* 2004: 442–443).

JEWELLERY IN THE KURA-ARAXES PHASE

The Kura-Araxes cemeteries do not generally demonstrate any clear social differentiation or stratification that the

¹² Another gold mine, possibly exploited already during the Kura-Araxes phase, was investigated in 2012 at Sotk in the Gegharkunik province of Armenia by a mission from the Institute of Archaeology and Ethnography of the National Academy of Sciences of the Republic of Armenia and the Universities of Halle and Tübingen, directed by A. Bobokhyan.

quality and frequency of jewellery items could support. Grave architecture and associated grave goods are generally standardised and they seem to reflect the prominence of horizontal relations in Kura-Araxes communities. This is probably evidence of an egalitarian society, which favoured horizontal rather than vertical bonds (Palumbi 2007: 25). Kura-Araxes society comprised mostly related families bonded by marriages, alliances or group affiliations. Chiefs and leaders are almost invisible in burial assemblages. Only at Arslantepe does the rich collection of jewellery in the 'royal tomb'

suggest the existence of social differences among members of the community that settled the site. The new group ruling the settlement was expressed through innovative burial customs combined with local traditions and through the introduction of prestigious burial goods (Frangipane *et alii* 2001: 105–136). It is still unclear whether this change was a legacy of an older local elite or evidence for the rise of a new political class, but in any case, it introduced a new social and political organisation that developed gradually in the beginning of the Early Kurgan culture in the southern Caucasus.

JEWELLERY IN THE EARLY KURGAN PHASE: THE CASE OF BEDENI CULTURE

The transition to the subsequent Early Kurgan phase began in a narrowly circumscribed area in the southern Caucasus around the mid-3rd millennium BC (about 2600 BC).¹³ This phase is commonly subdivided into two main stages: the Martqopi–Early Trialeti (Early Kurgan I) and the Bedeni (Early Kurgan II), but the still tentative knowledge of the former phase practically excludes it from the present discussion.

In the archaeological record there is little evidence of settled areas or architecture in settlements of the Bedeni phase. Kura-Araxes sites were gradually abandoned probably towards the mid-3rd millennium BC and not reoccupied

for a long period. The total absence in archaeological site stratigraphies of evidence of violent events or destruction is important to observe. Instead, there is an evident trend, expressed in reduced numbers of buildings, followed by a total absence of any trace of occupation, towards the end of the Kura-Araxes phase.¹⁴ The main causes of this decline and its exact date remain unclear.¹⁵ The beginning of the Early Kurgan phase was mainly linked to a local emergence of kinship groups ruled by chiefs. These groups rapidly acquired and legitimized strong positions of power on the base of land appropriation, control of raw material sources (and trade) and ownership of precious, exotic,

¹³ For a general overview of the chronology of the Early Kurgan phase, see Edens 1995: 56–58; Di Nocera 2000: 78–79; Kavtaradze 2004: 548–549; Sagona 2004: 477–479; Lyonnet 2007: 13.

¹⁴ Kvatskhelebi and Khizanaant Gora, both in the Shida Kartli region, are good examples. Both were resettled later (Glonti *et alii* 2008: 153).

¹⁵ At some sites, e.g., Sos Höyük in eastern Anatolia, Kura-Araxes material was attested in the archaeological record until the end of the 3rd millennium BC (around 2100 BC), and consequently a possible overlap between this phase and that of the Early Kurgan has been suggested (Sagona 2004: 479). The issue remains open.

prestige-marking goods. Early Kurgan communities continued to move through already settled places, leaving traces of their presence mainly in southeastern Georgia (Kvemo Kartli, Kakheti, Shida Kartli), Armenia and Dagestan. These were mostly semi-nomadic transhumant communities, used to frequent movement throughout the region for trade and in search of suitable pastures for their herds.

This archaeological phase is known mostly through the evidence of mortuary remains. Bedeni groups buried their leaders in large kurgans (hill graves) accompanied by many wealthy and remarkable goods. Kurgans were built in the highlands, as well as lowlands, depending on natural features in each case. These were frequently grouped, and areas with older kurgans were frequently reused over time. Kurgan features slightly changed over time: barrows were generally made of soil and stones, usually round or oval in shape, and mainly with underground grave chambers. Graves were placed in simple shafts or in pits lined with stones or wood and sometimes wooden houses were placed in the shafts (Carminati 2011: 251–253). The most significant example of Bedeni kurgans was discovered at the key-site of Bedeni, in Kvemo Kartli (Gobejishvili 1980: 33–79). It consisted of a group of hill graves, one of which (No. 5) had a complete funerary log house built inside a deep shaft. This grave held a very rich set of pottery vessels, metal objects, lithics, jewellery and a complete four-wheeled wooden wagon, where the corpse of the grave's owner lay.

An abundance of burial goods is typical of Bedeni graves. Among these, jewellery is

one of the most remarkable and richest class of finds. In the Bedeni phase, jewellery was made predominantly of precious metals, such as gold and silver, seldom bronze or arsenical copper as attested mostly in the Kura-Araxes phase.

From a morphological point of view it is possible to distinguish several classes of objects: pins (double-volute-headed, disc-shaped flat-headed, and sphere-shaped-headed), spiral-shaped ornaments (hair-rings, bracelets), pectorals, pendants, beads, and zoomorphic figurines.¹⁶

CLASS A: PINS

A.4 Double-volute-headed pins

Only a few examples of double-volute-headed pins have been found in Bedeni contexts (Gambashidze *et alii* 2010: 188, Pl. 16). The attested type had a flat, decorated head with double-volutes, cast in one piece, and joined to a thin shaft

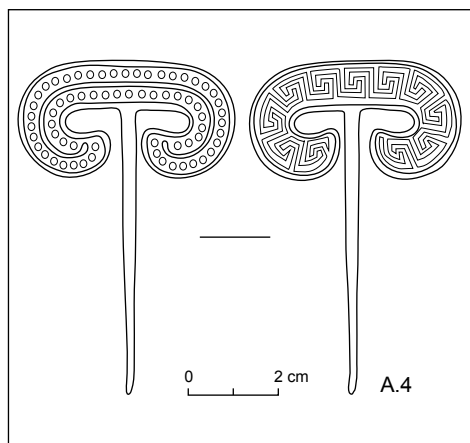

Fig. 10. Double-volute-headed pin: type A.4, Bedeni (After Gambashidze *et alii* 2010: 238, Pl. G-4, No. 60 a–b)

¹⁶ So far jewellery has been associated solely with personal ornaments, but for the following discussion it was deemed relevant to include also figurines because of the materials used in their production and the symbolic meaning of these objects. Even if not worn, such finds enhanced the social role and wealth of the owners in relation to the community.

(Gambashidze group I, d). The pins were made of gold and were characterised by very fine decoration on the heads (Gobejishvili 1980: Pl. XXXIX), for instance, the pin found in Bedeni Kurgan 5 [Fig. 10]. The head of this pin was decorated with two rows of small circles and a fine braided motif between them and along the edges. The shaft has a sharp tip with two small notches (Miron, Orthmann [eds] 1995: 29, Fig. 8) and the other side of the head is decorated with a meander-like motif.

This pin type is typical of Bedeni contexts and was first manufactured in this phase. Similar finds have also been recorded in the Martqopi/Early Trialeti (Kushnareva 1997: 91) and Middle Bronze Age/Trialeti grave inventories in Georgia (Miron, Orthmann [eds] 1995: 235, No. 85). These pins were all manufactured in the same way and differed only with

regard to the decorative patterns appearing on the heads.

A.5 Disc-shaped flat-headed pins

Pins of this type (Gambashidze group II; Gambashidze *et alii* 2010: 189, Pl. 17) had a flattened, rounded (**subtype A.5.1**) or leaf-shaped (**subtype A.5.2**) head with a thin, straight shaft, usually with a sharp end [Fig. 11]. The head of some exemplars, such as from Modinakhe [Fig. 11, right] (Gambashidze *et alii* 2001: 264, Fig. 70) was pierced and the upper part of the shaft, immediately under the head was rolled (**subtype A.5.3**) (Gambashidze group II,a; Gambashidze *et alii* 2010: 189, Pl. 17). These pins were always made of copper and were initially cast in one piece and then forged.

Disc-shaped flat-headed pins began to be produced during the mid-Early Bronze

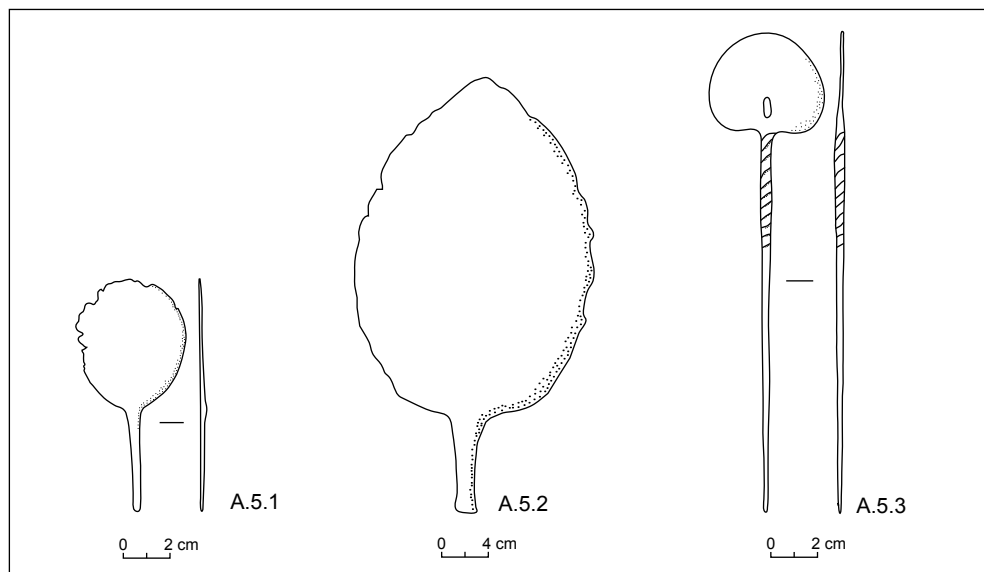

Fig. 11. Disc-shaped flat-headed pins: subtypes A.5.1, Bedeni (After Gambashidze *et alii* 2010: 551, Pl. 41, No. 696); A.5.2, Martqopi (After Gambashidze *et alii* 2010: 552, Pl. 52, No. 715); A.5.3 from Modinakhe (After Gambashidze *et alii* 2010: 556, Pl. 46, No. 776)

Age (Bedeni phase), becoming very common in the central Caucasus during the Middle Bronze Age (Gambashidze *et alii* 2001: 288–289, Figs 114–115).

A.6 Sphere-headed pins

Another remarkable pin type is represented by sphere-headed pins (Gambashidze group VI; Gambashidze *et alii* 2010: 191, Pl. 19). This type is characterised by a little sphere located at the upper end and a cylindrical horizontal element joining the shaft to the sphere. The shaft of the example found at Modinakhe is ribbed both under the sphere and under the cylindrical feature, while its end is sharp [Fig. 12] (Gambashidze *et alii* 2001: 264, Fig. 71). Sphere-headed pins were imported from the northern and western Caucasus during the Early Bronze Age (Gambashidze *et alii* 2001: 264, Fig. 71). They were in fact seldom found in Bedeni contexts, as they were not originally manufactured in the area.

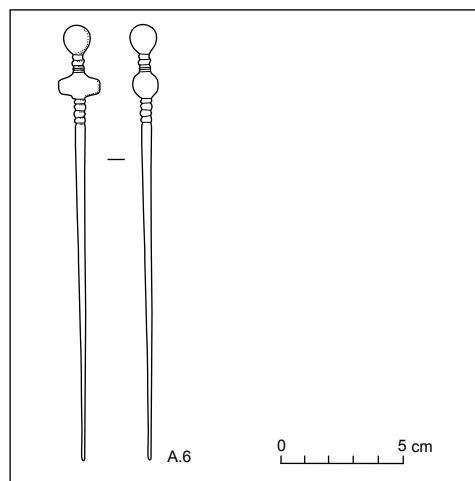

Fig. 12. Sphere-headed pin: type A.6, Modinakhe (After Gambashidze *et alii* 2010: 556, Pl. 46, No. 774)

CLASS B: SPIRAL-SHAPED ORNAMENTS

B.2 Spirals or hair-rings

Spirals or hair-rings were manufactured in the same way as in the Kura-Araxes phase. Rings with slightly rounded cross-sections were rolled in one and a half or more coils [Fig. 13]. They resembled Kura-Araxes rings in shape, but differed from them in the material. Kura-Araxes hair-rings, excluding those from the Arslantepe royal tomb context, were usually made of copper/arsenical copper alloy, whereas the Bedeni ones were frequently made of silver or gold. One of the richest inventories of this phase was discovered at Modinakhe in Imereti, where eight hair-rings were found in

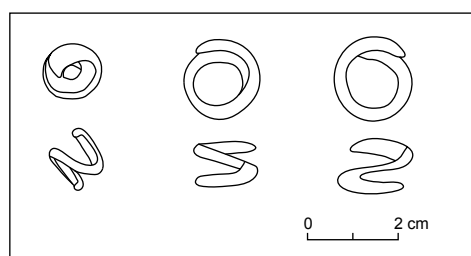

Fig. 13. Spiral-shaped ornaments: hair-ring (type B.2), Modinakhe (After Gambashidze *et alii* 2001: 265, No. 74)

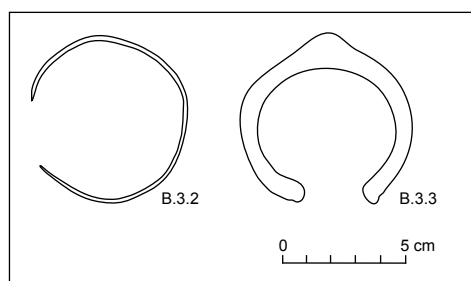

Fig. 14. Bracelets: subtypes B.3.2, Zhinvali, left; B.3.3, Modinakhe (After Gambashidze *et alii* 2001: 269, No. 78 and 265, No. 73)

a kurgan, of which two were of gold and four of silver (Lomtadze 1997: 9; Gambashidze *et alii* 2001: 265). This class of jewellery was abundantly attested in both earlier and later contexts in the Caucasus region, the eastern Mediterranean and Mesopotamia (Miron, Orthmann [eds] 1995: 265, Fig. 74).

B.3 Bracelets

Few bracelets have been discovered in Bedeni contexts. Unlike those of the Kura-Araxes phase, Bedeni bracelets consisted of a single twist only (**subtype B.3.2**), and have a very thin, rounded cross-section [Fig. 14, left]. These bracelets were first manufactured in the Bedeni period and then they were continuously produced in the subsequent Trialeti culture (Gambashidze *et alii* 2001: 269, Fig. 78).

Another bracelet subtype (**B.3.3**) was characterised by a thick metal band with rounded cross-section, thickened ends, and a spherical element in the middle [Fig. 13, right]. Similar exemplars have been found mainly in eastern Georgia, for example, at Modinakhe, and are very rare in Bedeni contexts (Gambashidze *et alii* 2001: 265, Fig. 73).

CLASS C: PECTORALS AND PENDANTS

Only one example of a fine openwork gold pectoral has been found in a Bedeni context, in Kurgan 2 at Ananauri (Miron, Orthmann [eds] 1995: 71, Fig. 50) [Fig. 15]. It is double-voluted, with a horizontal, triple-spool pierced feature. It was decorated with a braided motif running along the outer edges and encircling a geometric pattern, in which triangles, spirals and curved lines can be distinguished. This motif is reminiscent of the Bedeni double-volute pin described

above (**subtype A.4**) (Miron, Orthmann [eds] 1995: 29, Fig. 8) and of the Kura-Araxes double-volute pendants (subtype C.2). No exact parallels have been attested in other areas of Transcaucasia and only one other similar pendant (but upturned) was discovered in the Royal Cemetery of Ur (Aruz, Wallenfels [eds] 2003: 244).

Three double-spiral twisted pendants were also part of the Ananauri necklace (**subtype C.2**) (Abramishvili 2010: 168, Fig. 1; Pitskhelauri 2006: 34, Fig. 5)



Fig. 15. Pectoral pendant, subtype C.2, and shown on a necklace, which includes three double-spiral twisted pendants, subtype C.2, Ananauri Kurgan 2 (Drawing after Pitskhelauri 2006: 34, Pl. 5a; photo after Abramishvili 2010: 168, Fig. 1, No. 1)

[Fig. 15 top]. Such pendants were found in northern Mesopotamia and Anatolia in the 3rd millennium BC (Tonussi 2007: 175–180), and similarities have been observed with a quadruple-spiral pendant found in the Royal Cemetery of Ur (Abramishvili 2010: 169).

CLASS D: BEADS

Beads are well-attested in Bedeni contexts and like those from Kura-Araxes sites, they represent a variety of shapes and sizes: rounded (**subtype D.5**), cylindrical (**D.4**), oval (**D.6**), triangular (**D.7**), biconical (**D.3**), double- or triple-spool (**D.8** and **D.9**) and rhomboid (**D.10**) [Fig. 16]. Usually, they are grouped into bracelets or necklaces, for example, the Ananauri necklace, which was composed of several biconical, cylindrical and four double-spool beads (Pitskhelauri 2006: 34, Pl. 5) [see Fig. 15]. Spool-beads were typical of Martqopi–early Trialeti contexts (such as Kurgan 4; Miron, Orthmann [eds] 1995: 75, Fig. 55) and could have been reproduced in the Bedeni phase. Bedeni beads were usually made of precious metals, but semi-precious stone beads (of carnelian, obsidian etc.) have also been attested. Singling out an exclusively Bedeni

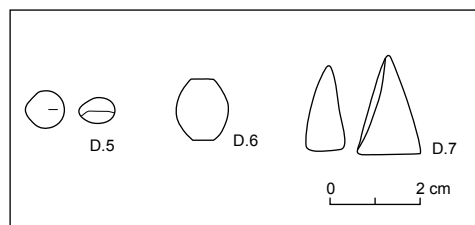

Fig. 16. Beads: subtypes D.5, D.6 and D.7 from Martqopi Kurgan 3 (Japaridze 1998: 42, Fig. 25, Nos 65–667)

repertoire of beads is difficult due to a long manufacturing tradition and common use; beads similar to the ones produced in the Early Bronze Age continued throughout the Middle Bronze (see Kushnareva 1997: 94–95, Figs 35–36).

CLASS F:¹⁷ ZOOMORPHIC FIGURINES

Zoomorphic figurines were attested for the first time in the southern Caucasus during the Bedeni phase. A golden stylized lion figurine was discovered in Tsnori Kurgan 2 [Fig. 17] (Dedabrishvili 1979: 41, Pl. LXVII). The object measures 5.2 cm

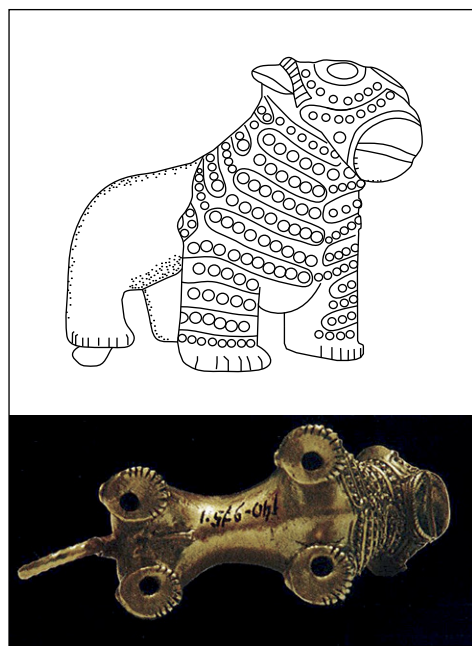

Fig. 17. Zoomorphic figurine from Tsnori Kurgan 2 and view of the hollow paw from underneath (Drawing and photo after Gambashidze et alii 2010: 237, Pl. G-3, No. 32)

¹⁷ There were no artifacts corresponding to Class E diadems of the Kura-Araxes Culture in this phase.

from head to tail, is 2.8 cm high and weighs 33 g (Chernykh 1992: 102–103; Miron, Orthmann [eds] 1995: 235). Its head and mane were schematically represented and the muzzle was formed of rows of small circles separated by lines in relief, two of which encircled a big knob representing the animal's eye. The paws were short and fat, the legs notched and the tail long and curved; the figurine was cast in one piece, using the lost-wax casting technique, and its decoration imitated granulation. The function of this figurine is still debated, but it was probably used either as part of a standard or placed on a stand (Miron, Orthmann [eds] 1995: 235). The lion paws are in fact pierced, possibly for narrow rods to be inserted [Fig. 17, bottom]. A wooden deer figurine, covered with gold and placed on a decorated stand, found at Trialeti, demonstrated some similarities with the Tsnori lion (Miron, Orthmann [eds] 1995: 30), hence the suggested same function for the Tsnori item. Zoomorphic figurines were later attested in the southern Caucasus during the Late Bronze–Early Iron Age, when they were usually made of bronze to be used as part of standards (see Miron, Orthmann [eds] 1995: 246, 256).

RAW MATERIALS AND MANUFACTURING TECHNIQUES
 Bedeni jewellery was made mainly of precious metals and gold was more frequently attested than silver. Gold was probably mined in the Sakdrisi area and silver was extracted from lead ores, directly from the Caucasus or imported from Anatolia (see Gambashidze *et alii* 2001: 80). Other jewellery were made of copper and arsenical copper alloy, while tin-bronze, imported already in an alloyed state, appeared for the first

time but on a minor scale (Abramishvili 2010: 169). Semi-precious stones, such as carnelian, rock crystal, marble and alabaster, were also common in the Bedeni jewellery repertoire (e.g., Tsnori Kurgan 1; Dedabrishvili 1979: Pl. LXXV).

Bedeni artisans partly reproduced and replicated shapes and techniques that originated and developed in the Kura-Araxes phase, but other items were absolutely original and innovative. One should keep in mind the long manufacturing tradition of some forms, such as hair-rings and beads, reaching well beyond the southern Caucasus.

Hot and cold forging as well as casting, already attested in the Kura-Araxes phase, were the main manufacturing techniques in the Bedeni period, but new technologies were also introduced. The Tsnori lion is evidence for the use of the lost-wax casting technique, which must have been considered as highly suitable for reproducing the shape and plasticity of the figure. Moreover, the Tsnori lion, the pectoral from Ananauri and the double-volute-headed pin from Bedeni show that although soldering was still unknown to the Transcaucasian metalsmiths, they were able already to decorate their works with applied elements of gold imitating filigree and granulation (Abramishvili 2010: 169).

JEWELLERY IN THE BEDENI PHASE

Bedeni jewellery has been discovered only in burial contexts, associated with graves of community chiefs. The amount of jewellery in graves, as well as the materials involved in their manufacture, are usually considered a distinguishing feature of the richest tombs. These features vary extensively from site to site and from region to region,

and might vary as well in relation to different social groups. Bedeni kurgans in Shida Kartli, for instance, lacked precious jewellery in their burial assemblages

either because the communities were not as wealthy or because local customs did not involve burying precious goods in the graves (Carminati 2011: 61–96).

KURA-ARAXES AND BEDENI JEWELLERY: PARALLELS AND DIFFERENCES

Data from an analysis of southern Caucasus Late Chalcolithic–Early Bronze Age jewellery enable a discussion of some of the peculiar features of this transitional phase dated to the beginning of the 3rd/mid-3rd millennium BC. The focus has been mainly on jewellery morphology and manufacturing techniques in a diachronic perspective with a supra-regional localization of production (a more local-oriented debate on the geographical distribution of these goods has been discussed extensively in Gambashidze *et alii* 2010). The objective was to compare jewellery assemblages of two possible subsequent cultural groups in an effort to identify elements of continuity and/or discontinuity.

The manufacture of jewellery in the Kura-Araxes culture was highly standardized and conventional. The few classes of jewellery that were identified were produced with little variability over a long period of time. Technical skills reflected already known technological *formulae*, which did not entail the introduction or development of innovative methods. Materials employed for the manufacture of everyday tools and weapons were also used for jewellery, meaning that shape and not formal appearance or material determined function and purpose. The presence of jewellery in grave assemblages indicates intentional burial as part of the grave goods, but finds of jewellery were also made in settlements.

In the Kura-Araxes jewellery assemblage pins were the most diverse class of finds, possibly because of their common use and distribution. Three types with a total of eight subtypes were distinguished. Similarly, spiral-shaped ornaments were relatively frequent, functionally grouped as rings, hair-rings and bracelets. Beads were, as expected, the class with the largest number of finds and morphological diversity, but the long production span and repetition of similar shapes over time does not allow to single out any particular selection.

Diadems were a remarkable class of jewellery, appearing only in the Kura-Araxes period. The importance of this small class of finds is highlighted by an exclusive association with burials of preeminent members of the community, expressly defining social rank. The reciprocal association of unique luxury goods and people involved a clear social designation, which occurred only at the beginning of the Kura-Araxes phase. However, the absence of other distinctive finds in Kura-Araxes graves demonstrates a relation of equality between members of each group. In the transition from the Kura-Araxes to the Bedeni phase, some of the elements denoting individuals social rank gained in importance within the communities.

Jewellery of the Bedeni phase was represented by a few classes as well, but was less standardized than the Kura-Araxes

production. There were more unique objects, both in shape and manufacturing details, the jewellery being characterized by a combination of shape and material, as if the concurrent choice of a special shape and that of a precious or exotic material conferred value on an item. This peculiar combination may have derived from an exceptional taste and artistic sensibility of Bedeni artisans, who were true artists: they possessed exclusive skills and frequently experimented with creative and innovative technological solutions.

Pins were attested in three different types, all of which were manufactured for the first time. Double-volute-headed pins vaguely recalled Kura-Araxes specimens [Fig. 3], with elaborate decoration of the heads. The Ananauri pectoral which is similar to anchor-shaped pendants and double-volute-headed pins, as well as the gold lion provided a vehicle for the introduction of a new technique imitating filigree.

Continuity and discontinuity can both be observed in the transition from Kura-Araxes to Bedeni jewellery. Continuity largely concerns manufacturing techniques, which are the same on similar classes of objects. The only jewellery groups that remain the same are the relatively simple beads, hair-rings and slightly modified double-volute pins and pendants. Loss of standardization in jewellery during the Bedeni phase further emphasizes the selective purpose of some of these artifacts.

Deposition of high quality jewellery in graves in the Bedeni phase reflected a new understanding of the social and economic position held by certain members of the community. These singular artifacts can be rightly defined as *status symbols*, visibly denoting the chief's social rank.

They constituted part of the luxury items coveted by members of the community to indicate their position.

The connotation of jewellery also descends from the archaeological contexts of these finds: kurgans were a visible symbolic representation of the power and wealth of community leaders. This relation did not originate in the southern Caucasus, but developed in neighbouring regions and was introduced in the area possibly through the extensive Late Chalcolithic–Early Bronze Age trade network, which associated the southern with the northern Caucasus. Likewise, the emergence of complex societies in Transcaucasia can be linked to the relation with the newly born urban civilizations of Mesopotamia through the Anatolian plateau. Trade in unworked raw materials could have been regulated and controlled at least in part by the Bedeni leaders. These relations were not only one-way networks organized by advanced Mesopotamian communities, but might have involved reciprocal exchanges. There is no clear evidence of this in archaeological assemblages from western and central Transcaucasian sites, but the introduction of new manufacturing techniques in the Bedeni phase could suggest the circulation of technological innovations as part of this system. The southern Caucasus was not entirely dependent on this relation considering the strong standing of local traditions in its culture. This is attested by the continuous production of specific jewellery shapes throughout this period.

The evident strong cultural discontinuity in the southern Caucasus between the Kura-Araxes and the Bedeni phases could possibly be observed already in the initial Early Kurgan phase, also known as the

Martqopi–early Trialeti phase (of which the Bedeni culture is a later phase), which is however poorly known and studied.¹⁸ This phase is apparently characterised by some features showing continuity with both the Kura-Araxes (pottery production) and the Bedeni phases (funerary architecture). Spool-beads, for instance, are a peculiar Martqopi jewellery type adopted in the Bedeni phase. Further studies on the Late

Chalcolithic and Early Bronze Age periods should enable a better understanding of the actual input of different cultural groups into the overall jewellery repertoire.

ACKNOWLEDGMENTS

I wish to thank Dr. Elena Rova from Ca' Foscari University in Venice, Italy, for revising this paper and useful comments and suggestions.

Eleonora Carminati

University of Melbourne

Faculty of Arts, School of Historical and Philosophical Studies

Parkville, VIC 3010 Australia

e.carminati@student.unimelb.edu.au / ec.carminati@gmail.com

REFERENCES

Abramishvili, M.

- 2010 In search of the origins of metallurgy. An overview of South Caucasian evidence [in:] S. Hansen, A. Hauptmann, I. Motzenbäcker, E. Pernicka (eds), *Von Majkop bis Trialeti. Gewinnung und Verbreitung von Metallen und Obsidian in Kaukasien im 4.–2. Jt. v. Chr. Beiträge des Internationalen Symposiums in Berlin vom 1.–3. Juni 2006* [=Kolloquien zur Vor- und Frühgeschichte 13], Bonn: Habelt, 167–178

Amiran, R.

- 1952 Connections between Anatolia and Palestine in the Early Bronze Age, *Israel Exploration Journal* 2, 89–103
- 1965 Yanik Tepe, Shengavit and the Khirbet Kerak ware, *Anatolian Studies* 15, 165–167

Aruz, J., Wallenfels, R. (eds)

- 2003 *Art of the First Cities. The Third Millennium BC from the Mediterranean to the Indus*, New York: Metropolitan Museum of Art

Badalyan, R.S., Chataigner, C., Kohl, P.

- 2004 Trans-Caucasian obsidian: The exploitation of the sources and their distribution [in:] A. Sagona (ed.), *A View from the Highlands. Archaeological Studies in Honour of Charles Burney* [=ANES Supplement 12], Leuven: Peeters, 437–465

Bertram, J.-K.

- 2002 Schleifennadelfunde aus dem Kaukasusgebiet [in:] R. Aslan, S. Blum, G. Kastl, F. Schweizer, D. Thumm (eds), *Mauerschau. Festschrift für Manfred Korfmann II*, Remshalden-Grünbach: Greiner, 815–830

¹⁸ For a brief analysis of the Martqopi phase, see Japaridze 1993, and to some extent Miron, Orthmann [eds] 1995. Martqopi kurgans have been presented only in preliminary reports and one brief monograph in Georgian (Japaridze 1998).

- Brunet, O.
 2009 Bronze and Iron Age carnelian bead production in the UAE and Armenia: new perspectives, *Proceedings of the Seminar for Arabian Studies* 39, 57–68
- Carminati, E.
 2011 *The Bedeni Culture of III Millennium BC Transcaucasia: Available Data and Interpretations*, unpubl. MA diss., Ca' Foscari University of Venice
- Chernykh, E.N.
 1992 *Ancient Metallurgy in the USSR. The Early Metal Age*, Cambridge: Cambridge University Press
- Chernykh, E.N., Avilova, L.I., Berceva, T.B., Orlovskaja, L.B., Tenejshvili, T.O.
 1991 The Circumpontic metallurgical province as a system, *East and West* 41, 11–45
- D'Acchille, T.
 2011 *Il vello d'oro. Antichi tesori della Georgia*, Rome: Palombi Editori
- Dedabrishvili, Š.
 1979 *Kurgany Alazanskoj Doliny [The Kurgans of the Alazani Valley]*, Tbilisi: Metsniereba [in Georgian and Russian]
- Di Nocera, G.M.
 2000 Radiocarbon datings from Arslantepe and Norşuntepe: the fourth–third millennium absolute chronology in the Upper Euphrates and Transcaucasian region [in:] C. Marro, H. Hauptmann (eds), *Chronologies des pays du Caucase et de l'Euphrate aux IV^e–III^e millénaires. Actes du Colloque d'Istanbul, 16–19 décembre 1998 [=Varia Anatolica 11]*, Paris: Institut français d'études anatoliennes d'Istanbul, 73–93
- Edens, C.
 1995 Transcaucasia at the end of the Early Bronze age, *BASOR* 299–300, 53–64
- Frangipane, M., Di Nocera, G.M., Hauptmann, A., Morbidelli, P., Palmieri, A., Sadori, L., Schultz, M., Schmidt-Schultz, T.
 2001 New symbols of a new power in a “royal” tomb from 3000 BC Arslantepe, Malatya (Turkey), *Paléorient* 27/2, 105–139
- Gambashidze, I., Hauptmann, A., Slotta, R., Yalçın, Ü. (eds)
 2001 *Georgien. Schätze aus dem Land des Goldenen Vlies. Katalog der Ausstellung des Deutschen Bergbau-Museums Bochum in Verbindung mit dem Zentrum für Archäologische Forschungen der Georgischen Akademie der Wissenschaften Tbilissi vom 28. Oktober 2001 bis 19. Mai 2002*, Bochum: Deutsches Bergbau-Museum
- Gambashidze, I., Mindiashvili, G., Gogochuri, G., Kakhiani, K., Japaridze, I.
 2010 *Alte Metallurgie und Bergbau in Georgien im 6.–3. Jt.v. Chr.*, Tbilisi: Mtsignobari
- Gamkrelidze, G., Vickers, M. (eds)
 2010 *Rescue Archaeology in Georgia. The Baku-Tbilisi-Ceyhan and South Caucasian Pipelines*, Tbilisi: Georgian National Museum
- Glonti, L., Ketskhoveli, M., Palumbi, G.
 2008 The cemetery at Kvatskhelebi [in:] A. Sagona, M. Abramishvili (eds), *Archaeology in Southern Caucasus. Perspectives from Georgia [=ANES Supplement 19]*, Leuven–Dudley, MA: Peeters, 153–184
- Gobejishvili, G.
 1980 *Bedenis gorasamarkhebis kultura [The culture of Bedeni kurgans]*, Tbilisi: Metsniereba

- Greenberg, R.
2007 Transcaucasian colors: Khirbet Kerak Ware at Khirbet Kerak (Tel Bet Yerah) [in:] B. Lyonnet (ed.), *Les cultures du Caucase (VT^e-III^e millénaires avant notre ère). Leurs relations avec le Proche-Orient*, Paris: CNRS Éditions, 257–268
- Huot, J.-L.
1969 La diffusion des épingles à tête à double enroulement, *Syria* 46/1–2, 57–98
- Japaridze, O.
1993 Über die ethnokulturelle Situation in Georgien gegen Ende des 3. Jahrtausends v. Chr. [in:] M. Frangipane, H. Hauptmann, M. Liverani, P. Matthiae, M. Mellink (eds), *Between the Rivers and Over the Mountains. Archaeologica Anatolica et Mesopotamica Alba Palmieri Dedicata*, Rome: Università di Roma “La Sapienza”, Dipartimento di scienze storiche archeologiche e antropologiche dell’antichità, 475–491
1998 *Kartveli tomebis etnokulturuli istoriisatvis zv. C. III atascleulsi. Adreqorganuli kultura* [*On the Ethnocultural History of the Georgian Tribes in the 3rd Millennium BC*], Tbilisi: Tbilisi University Press [in Georgian]
- Kavtaradze, L.
2004 The chronology of the Caucasus during the early metal age. Observations from central trans-Caucasus [in:] A. Sagona (ed.), *A View from the Highlands. Archaeological Studies in Honour of Charles Burney [=ANES Supplement 12]*, Leuven: Peeters, 539–556
- Kiguradze, T., Sagona, A.
2003 On the origins of the Kura-Araks cultural complex [in:] A.T. Smith, K.S. Rubinson (eds), *Archaeology in the Borderlands. Investigations in Caucasia and Beyond [=Cotsen Institute of Archaeology at UCLA Monograph 47]*, Los Angeles: Cotsen Institute of Archaeology at UCLA, 38–94
- Kuftin, B.
1941 *Arheologičeskie raskopki v Trialeti*, Tbilisi: Izdatel’stvo Akademii Nauk Gruzinskoj SSR
- Kushnareva, K.
1997 *The Southern Caucasus in Prehistory. Stages of Cultural and Socioeconomic Development from the Eight to the Second Millennium B.C. [=University Museum Monograph 99]*, transl. by H.N. Michael, Philadelphia: University of Pennsylvania Museum
- Leskov, A.M.
2008 *The Maikop Treasure*, Philadelphia: University of Pennsylvania Museum of Archaeology and Anthropology
- Lomtadze, G.
1997 *Akhladaghmochenili samarkbi modinakbedan* [*The Newfound Tomb from Modinakhe*] [=*Sakartvelos khelovnebis muzeumis narkvevebi* 3], Tbilisi [in Georgian]
- Lordkipanidze, O.
1991 *Archäologie in Georgien: von der Altsteinzeit zum Mittelalter* [=*Quellen und Forschungen zur prähistorischen und provinzialrömischen Archäologie* 5], Weinheim: VCH, Acta Humaniora
- Lyonnet, B.
2000 La Mésopotamie et le Caucase du Nord au IV^e et au début du III^e millénaires av. N. E.: Leurs rapports et les problèmes chronologiques de la culture de Majkop. Etat de la question et nouvelles proposition [in:] C. Marro, H. Hauptmann (eds), *Chronologies des pays du Caucase et de l’Euphrate aux IV^e-III^e millénaires. Actes du Colloque d’Istanbul, 16–19 décembre 1998* [=*Varia Anatolica* 11], Paris: Institut français d’études anatoliennes d’Istanbul, 299–320

- 2007 Introduction [in:] B. Lyonnet (ed.), *Les cultures du Caucase (VI^e–III^e millénaires avant notre ère). Leurs relations avec le Proche-Orient*, Paris: CNRS Éditions, 11–19
- Marro, C., Bakhshaliyev, V., Ashurov, S.
 2011 Excavations at Ovuçular Tepesi (Nakhchivan, Azerbaijan). Second preliminary report: the 2009–2010 seasons, *Anatolia Antiqua* 19, 53–100
- Marro, C., Hauptmann, H. (eds)
 2000 *Chronologies des pays du Caucase et de l'Euphrate aux IV^e–III^e millénaires. Actes du Colloque d'Istanbul, 16–19 décembre 1998 [=Varia Anatolica 11]*, Paris: Institut français d'études anatoliennes d'Istanbul
- Miron, A., Orthmann, W. (eds)
 1995 *Unterwegs zum Goldenen Vlies. Archäologische Funde aus Georgien*, Saarbrücken: Museum für Vor- und Frühgeschichte Saarbrücken
- Mindiashvili, G.
 2012 Earliest diadems from Shida Kartli, *Studies in Caucasian Archaeology* I, 4–11
- Mirtskhulava, G.
 2011 *Problems of Kura-Araxes Culture [=Studies of the Society of Assyriologists, Bibliologists and Caucasiologists 5]*, Tbilisi: SABC
- Moorey, P.R.S.
 1994 *Ancient Mesopotamian Materials and Industries : The Archaeological Evidence*, Vinona Lake: Eisenbrauns
- Palumbi, G.
 2007 From collective burials to symbols of power. The translation of role and meanings of the stone-lined cist burial tradition from southern Caucasus to the Euphrates valley, *Scienze dell'Antichità* 14/1, 17–44
 2008 *The Red and Black. Social and Cultural Interaction between the Upper Euphrates and Southern Caucasus Communities in the Fourth and Third Millennium BC [=Studi di preistoria orientale 2]*, Rome: Dipartimento di Scienze Storiche Archeologiche e Antropologiche dell'Antichità, Sapienza Università di Roma
 2009 Collassi, trasformazioni e mondo Kura-Araks nell'alta valle dell'Eufrate tra IV e III millennio. Sviluppi locali o migrazioni?, *Scienze dell'Antichità* 15, 125–139
- Pitskhelauri, K.
 2006 Arheologičeskie issledovaniâ 1990–2004 gg. v Kaheti (itogi i perspektivy) [Archaeological investigations in Kakheti in 1990–2004 (results and prospects)], *Arheologičeskaja Kavkaza* 1, 23–54 [in Russian with English summary]
- Pittman, H.
 1998 Jewelry [in:] R.L. Zettler, L. Horne (eds), *Treasures from the Royal Tombs of Ur*, Philadelphia: University of Philadelphia Museum, 87–122
- Puturidze, M., Rova, E. (eds)
 2012 *Khashuri Natsargora. The Early Bronze Age Graves. Publications of the Georgian–Italian Shida Kartli Archaeological Project I [=Subartu 30]*, Turnhout: Brepols
- Rova, E., Puturidze, M., Makharadze, Z.
 2011 The Georgian–Italian Shida Kartli Archaeological Project: a report on the first two field seasons 2009 and 2010, *Rivista di Archeologia* 34, 5–30
- Sagona, A.
 1981 Spiral-headed pins: A further note, *Tel Aviv* 8, 152–159
 1984 *The Caucasian Region in the Early Bronze Age [=BAR IS 214]*, Oxford: Archaeopress

- 2004 Social boundaries and ritual landscapes in Late Prehistoric Trans-Caucasus and Highland Anatolia [in:] A. Sagona (ed.), *A View from the Highlands. Archaeological Studies in Honour of Charles Burney* [=ANES Supplement 12], Leuven: Peeters, 475–538
- Stöllner, T., Gambaschidze, I., Hauptmann, A., Mindiashvili, G., Gogochuri, G., Steffens, G.
2010 Goldbergbau in Südostgeorgien — Neue Forschungen zum frühbronzezeitlichen Bergbau in Georgien [in:] S. Hansen, A. Hauptmann, I. Motzenbäcker, E. Pernicka (eds), *Von Majkop bis Trialeti. Gewinnung und Verbreitung von Metallen und Obsidian in Kaukasien im 4.–2. Jt. v. Chr. Beiträge des Internationalen Symposiums in Berlin vom 1.–3. Juni 2006* [=Kolloquien zur Vor- und Frühgeschichte 13], Bonn: Habelt, 103–138
- Tonussi, M.
2007 *Dall’Eufrate allo Scamandro. Contatti e scambi nel III millennio a.C.*, Padua: Il Poligrafo