

# Zbigniew E. Szafrański

---

## Temple of Hatshepsut at Deir El-Bahari, Seasons 2006

---

Polish Archaeology in the Mediterranean 19, 251-268

---

2010

Artykuł został opracowany do udostępnienia w internecie przez Muzeum Historii Polski w ramach prac podejmowanych na rzecz zapewnienia otwartego, powszechnego i trwałego dostępu do polskiego dorobku naukowego i kulturalnego. Artykuł jest umieszczony w kolekcji cyfrowej [bazhum.muzhp.pl](http://bazhum.muzhp.pl), gromadzącej zawartość polskich czasopism humanistycznych i społecznych.

Tekst jest udostępniony do wykorzystania w ramach dozwolonego użytku.

# TEMPLE OF HATSHEPSUT

## AT DEIR EL-BAHARI, SEASON 2006/2007

Zbigniew E. Szafrąński

*The Polish-Egyptian Mission to the Hatshepsut Temple at Deir el-Bahari carried out a program of work between 26 October 2006 and 2 May 2007.*

*The main objective of the two seasons was the restoration of the Complex of the Sun Cult, conservation of the Southern Chamber of Amun-Re, and continued documentation work and excavation in the Complex of the Royal Mortuary Cult and an area located to the south of this Complex. The Hathor Retaining Wall, located above and west of the Hathor Shrine Vestibule, was reinforced; its top was restored with two layers of stone blocks.*

*Epigraphic documentation of the North Wall of the Upper (Festival) Courtyard rounded off the restoration completed in previous seasons. It was also needed to make progress on a study of scenes of the “Beautiful Feast of the Valley”. Documentation studies of scenes including figures of Neferure-Ahmoose discovered recently in the Courtyard (cf. Szafrąński 2009: 280–283 and Figs 11–12) were dictated by their inherent ideological importance.*

1 The staff included: Zbigniew E. Szafrąński, egyptologist (Director); Mirosław Barwik, egyptologist (Deputy Director); Teresa Kaczor, Chief Architect (Deputy Director); Izabela Uchman-Laskowska, Chief Conservator; Olga Białostocka, egyptologist; Aleksandra Brzozowska, architect; Marta Cytryńska, archaeologist; Monika Czerniec, conservator; Andrzej Ćwiek, egyptologist; Monika Dolińska, egyptologist; Mariusz Dybich, technician; Jadwiga Iwaszczuk, egyptologist; Maciej Jawornicki, photographer; Grażyna Karpińska, architect; Marlena Koczorowska-Pyzik, conservator; Fabiola Kolago, student of archaeology; Edyta Kopp, egyptologist; Karol Kwiatkowski, student of archaeology; Maria Mathia, student of archaeology; Mieczysław Michiewicz, engineer-constructor; Agnieszka Niemirka, archaeologist; Wojciech Osiak, conservator; Marek Puzkarski, documentalist; Paweł Sobczyński, conservator; Anastazja Stupko, egyptologist; Dawid Wiczorek, student of archaeology; volunteers: Marta Ćwiek, Joanna Lis, Małgorzata Kujawa, Anna Longa, Szymon Maślak, Monika Więch. The Supreme Council of Antiquities (SCA) was represented by inspectors: Hasan Ali Ahmed, Mahmoud Abdallah M. Ammar and Mohamed Yousuf Mohamed.

We would like to express sincere gratitude to Dr. Zahi Hawass, Secretary General of the SCA; Sabry Abd El Aziz Khater, General Director of the Pharaonic Department of the SCA, and Ali Al-Asfar, General Director of Antiquities in el-Gurna (SCA), for their invaluable help and continuous support.

Special thanks are due Dr. Janusz Garecki (Henkel-Polska Co.) for his understanding and valuable help in our conservation and restoration projects.

*Statues of Hatshepsut and related sculptures found in the Deir el-Bahari area by the Metropolitan Museum of Art expedition were also studied.*

*In two storerooms housing fragments of reliefs from the temple of Tutmosis III, activities centered on completing a theoretical reconstruction of the iconographic program of the temple decoration.*

*Aside from the main program, the mission also expedited some artifacts from the Deir el-Bahari and Luxor Museum stores for presentation at the “Seventy Years of Polish Archaeology in Egypt” exhibition held in the Egyptian Museum in Cairo in October-December 2007 (extended to January 2008).*

## I. COMPLEX OF THE SUN CULT

The work undertaken comprised partial conservation and restoration of the so-called Great Altar [Fig. 1], color unification of the north and south walls of the courtyard, and conservation of a painted representation of

Re-Horakhty in the entrance to the Complex. The restoration work in the Complex is presented in a separate report by Teresa Kaczor and Mieczysław Michiewicz in this volume.



Fig. 1. *Complex of the Sun Cult: the Sun Altar after cleaning, conservation and restoration (Photo M. Jawornicki)*

## I.1. SUN ALTAR

In the Great Sun Altar, many of the previous fillings have been changed. In different parts of the altar, over twenty fragments missing from the stone blocks were restored with patches of new local limestone. The reconstructed elements were fixed mainly with mortar (composed of lime, white cement and sifted medium sand).<sup>2</sup> For the biggest pieces, especially from the *cavetto* and cornice, a polyester resin was used because of its short binding time permitting precise fittings. Gaps between original stone blocks were filled with new mortar containing two parts white cement, two parts white mineral dust (fine sieved), one part red mineral dust (fine sieved), and one part sand (fine sieved). Standard procedures for differentiating the new surfaces from old ones were applied.

The goal being to show the building history of the complex, which in the case of the Altar comprises at least three separate undertakings during the reign of Hatshepsut, the conservators prepared an exposition of elements belonging to the different building stages. In effect, the southeastern corner of the so-called Small Altar can now be viewed in relation to the masonry from the next two stages of the altar's construction [Fig. 2]. The blocks, which were in poor condition, had to be reinforced with a silica binder FUNCOSIL STEINFESTIGER 300 and 500 by Remmers. Layers of plaster no longer adhering to stone surfaces were consolidated with PRIMAL AC33 (5% water-diluted). Parts of mortar in the upper surface of the Altar were reinforced with injections of PRIMAL AC33 (15% water-diluted).

## I.2. NORTH AND SOUTH WALLS OF THE COURTYARD

Continued work on the north and south walls of the Courtyard covered pointing of the joints and cleaning and consolidation of ancient (original) mortar fillings using FUNCOSIL STEINFESTIGER 500 KSE by Remmers with an addition of mineral filler aggregate. Plaster coatings were consolidated with PRIMAL AC33 (5% to 15% water-diluted).



Fig. 2. Inside the masonry of the Great Altar: visible southeastern corner of the Small Altar (Photo M. Jawornicki)

2 All remarks concerning restoration activities draw upon the unpublished report from the season's works by the conservator in charge, Izabela Uchman-Laskowska; all mission reports are kept in the PCMA archives in Warsaw.



Fig. 3. *Hatshepsut between Re-Horakhty and Amun-Re, wall painting in the entrance to the Sun Cult complex. State after conservation (Photo M. Jawornicki)*

### I.3. THE RE-HORAKHTY WALL PAINTING

A painted representation of Hatshepsut between Re-Horakhty and Amun-Re on the west wall of the entrance to the Complex underwent comprehensive conservation treatment [*Fig. 3*]. Gaps between blocks were

filled with mortar following procedures applied for wall-painting conservation in the Southern Chamber of Amun (cf. report by Izabela Uchman-Laskowska in this volume). A glass panel will be mounted in front of the painting in order to protect it once the complex is opened to the visiting public.

## II. COMPLEX OF THE ROYAL MORTUARY CULT

Work continued on the documentation of the relief decoration and text in different parts of the Complex, including hundreds of loose fragments believed to come from this part of the Temple, and now painstakingly fitted into place. Several new attributions were made, most importantly in gaps in the inscriptions decorating the walls and ceiling of the Cult Chapels of Hatshepsut (CH) and Tuthmosis I (CT.I), and in the Courtyard and Vestibule of the Complex. The effects of this work, while essential to the restoration project, will also serve the purposes of a monograph of the Complex which is now being prepared by Mirosław Barwik.

The western retaining wall behind and above the Hathor Shrine, called Wall 01/07 (south of the Royal Mortuary Cult complex), and the Hathor Retaining Wall (RW-H), were partly restored and reinforced. This required a special buttress construction to be designed (Mieczysław Michiewicz, documentation in the mission's archives) between this wall and the roof slabs of the Vestibule of the Hathor Shrine (HS-V) of the Middle Terrace. Two courses of original stones were restored on the top of the wall.

### II.1. CHAPEL OF HATSHEPSUT

#### II.1.1. South and North Walls

Drawings of the decoration of the upper part of the North and South Walls of the

Chapel were completed this season. Some of the blocks used in the restoration from over a hundred years ago turned out to be positioned incorrectly. Ten new decorated blocks were attributed to these walls.

#### II.1.2. Excavations in the Chapel (S/07)

Exploration of the southern part of the pavement in the Chapel has reached rock, uncovering a few original limestone paving blocks still in place and locating three more tombs [*Fig. 4*]. The archaeological material is mixed and comes from different historical periods. The chapel foundations were uncovered and appropriate steps taken to reinforce them with special steel-and-stone protecting structures (design by Mieczysław Michiewicz).

##### II.1.2.1. Coptic Church Pavement

Remains of the Coptic church pavement (L.4/07), located approx. 8.80–10 m east of the Chapel's west wall, consisted of about ten limestone blocks positioned (N–S) directly on the rock, including a block from the destroyed temple architrave. A group of blocks (L.2/08) to the northwest of L.4/07, apparently from the same installation, may have formed the foundation of the east wall of the church that had once been located inside the Chapel. These blocks were covered with three thin layers (5–7 cm) of mortar, chips of Esna shale, crushed red-bricks, fine gravel and sand.

This pavement (L.4/07 and L.2/08) and the deposit L.1/05, which includes material from the leveling layer found in the western part of the Chapel, constitute remains of the Coptic church.

**II.1.2.2. Late Roman/Coptic Tomb (S.1/07)**  
Excavations in the Chapel in 1981/1982 (test pit S-6), covering the base of the south wall, the southeastern corner and the paved area in the entrance to the chapel, had not been completed at the time. The present work concentrated on the southeastern corner of the Chapel, unearthing an installation made of red- and mud-bricks [Fig. 5]. Judging by the lower part, which was hewn in rock below the level of the Chapel pavement (overall dimensions approx. 2 m N-S by 1.60 m), this structure consisted of two rooms divided by a partition wall approx. 0.15 m thick. Unit A was approx. 1.95 m N-S long by 0.80 m wide and at least 1.15 m high, Unit B, respectively, 1.95 m by 0.46 m and at least 0.70 m high. Of the upper parts of this installation little has been

preserved: remains of a vault in the southwestern corner of Unit A, approx. 0.90 m above the floor, and two courses of bricks in the northern part of Unit A, apparently from the wall facing the said vault. Ancient builders may have actually reused the earlier shaft-mouth of S.3/07, located below the floor of Unit A for their purposes. The original height of the installation, estimated on the grounds of the preserved remains, should have been less than 1.80 m.

The inside walls of the two units and the pavement had been given a coat (perhaps two) of whitewashed plaster. Consequently, since the remains of the purported north wall of unit A stand on a 3-cm layer of plaster, it must have been erected already after the interior had been plastered. The pavement in the central part appears to have been robbed in antiquity.

The archaeological material from the trench was fragmentary and chronologically mixed, but most of it dates from the Coptic period. The most characteristic of the lot were typical linen plain and colored tapes,

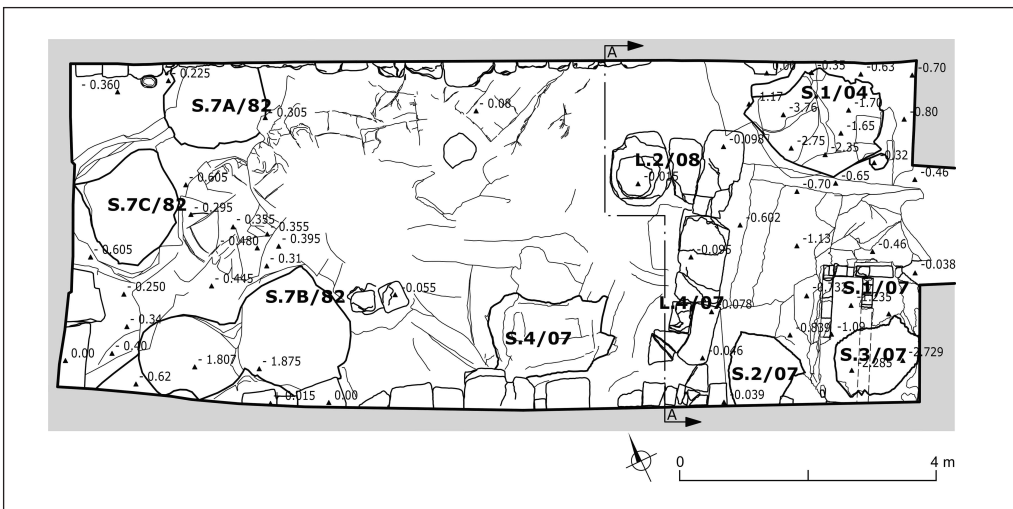
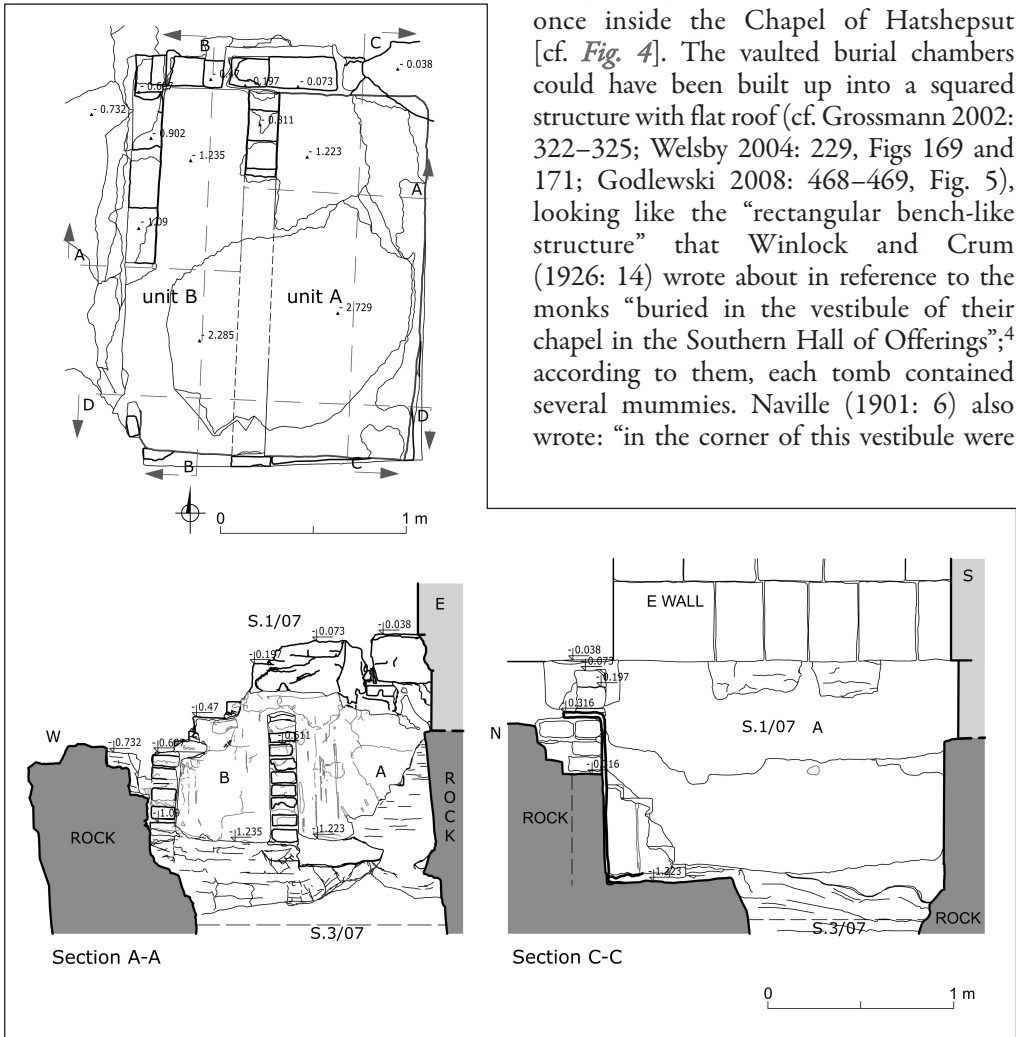

Fig. 4. Localization of trial trenches inside the Chapel of Hatshepsut (Drawing T. Kaczor, A. Brzozowska, G. Karpńska, D. Wiczorek)

6–10 mm wide, made in the tablet-weaving technique,<sup>3</sup> used for binding burial shrouds in the funerary practice of the Coptic period.

Assuming that this installation was a vaulted two-chamber Late Roman or Coptic tomb aligned north–south, it would have stood in front, that is, to the east of the church located once inside the Chapel of Hatshepsut [cf. *Fig. 4*]. The vaulted burial chambers could have been built up into a squared structure with flat roof (cf. Grossmann 2002: 322–325; Welsby 2004: 229, Figs 169 and 171; Godlewski 2008: 468–469, Fig. 5), looking like the “rectangular bench-like structure” that Winlock and Crum (1926: 14) wrote about in reference to the monks “buried in the vestibule of their chapel in the Southern Hall of Offerings”;<sup>4</sup> according to them, each tomb contained several mummies. Naville (1901: 6) also wrote: “in the corner of this vestibule were



*Fig. 5. Late Roman or Coptic Tomb (S.1/07) in the southeastern corner of the Chapel of Hatshepsut, plan and sections (Drawing A. Brzozowska)*

- 3 Compare the tapes found in Naqlun (Godlewski and Czaja-Szewczak 2008: 256, Figs. 11 and 14). The textiles found in the temple are the subject of study by Barbara Czaja-Szewczak.
- 4 H.E. Winlock and W. Crum visited the Temple in 1922. “The Southern Chapel” is the Chapel of Hatshepsut, “the vestibule of their chapel” means, most probably, the Vestibule of the Chapel (CH-V); at that time (in 1922), they did not see and knew nothing about the east wall of the church.



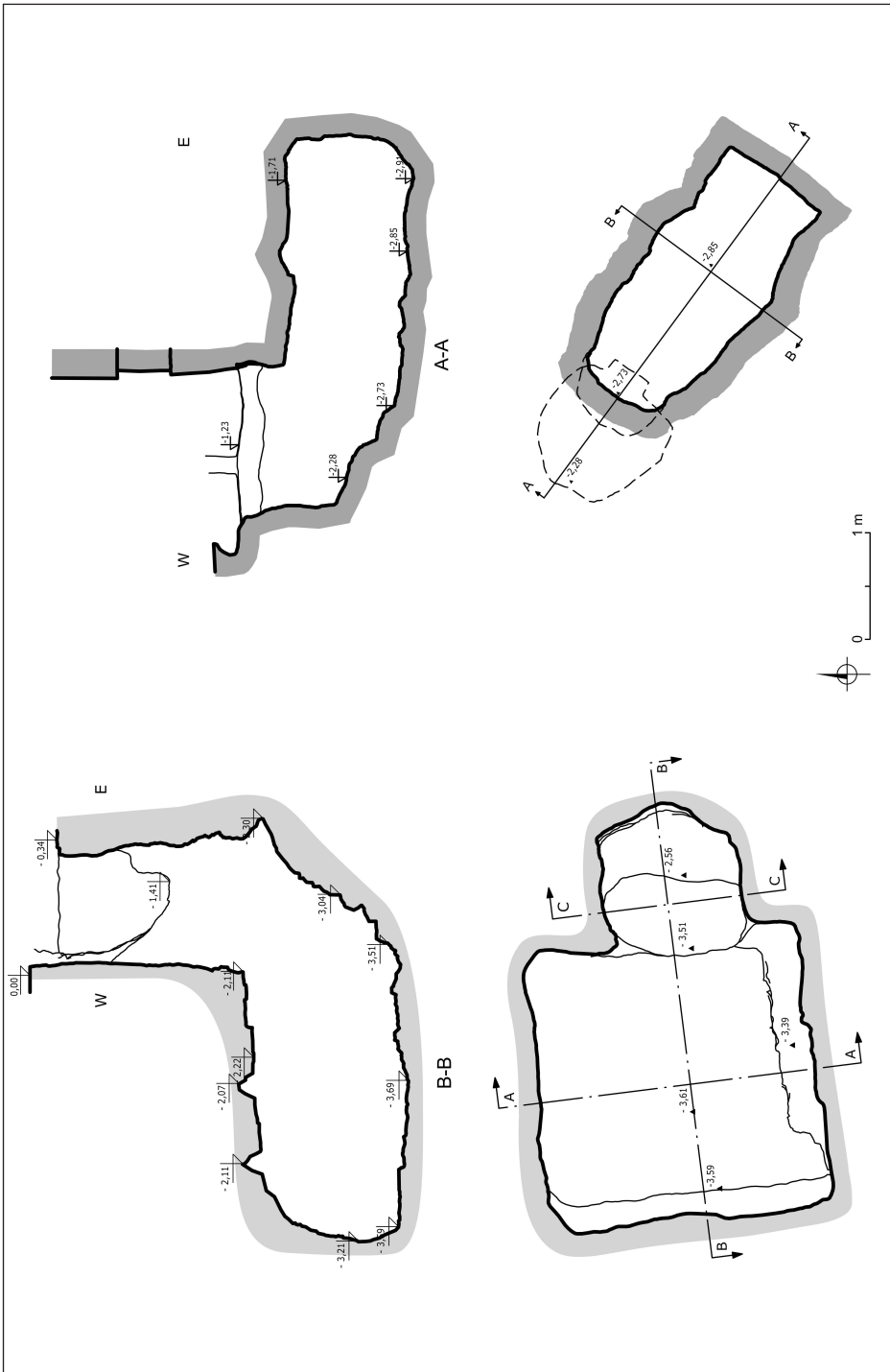

Fig. 6. Tombs S.2/07 (left) and S.3/07 inside the Chapel of Hatshepsut, plans and sections (cf. Fig. 4 for locations of each) (Drawing A. Brzozowska, left, and G. Karpínska)

some rectangular constructions in crude bricks, which at first sight looked like beds or seats. They were graves; each of them contained several Coptic mummies”.

The north–south alignment of structure S.1/07 is incompatible with the usual Christian practice,<sup>5</sup> hence it is possible that it belongs to the category of earlier “pagan” tombs (Winlock and Crum 1926: 14, note 1), discovered by Naville (1896: 5) on the Middle Terrace and can be dated to the Late Roman period. A provisional study of the assemblage from the structure also points to the 6th century (possibly earlier), but it should be kept in mind that the archaeological context here was disturbed.

Traces of an inscription(?), painted in red, were found on the east and south walls of the Chapel, above the tomb and below the dado decoration of the walls. One letter painted in red, “...H(?)...”, was preserved in the middle of what supposedly was a one-line inscription on the north wall of Unit B. The evidence is naturally insufficient, but the very location of the tomb and the quality of its execution suggests a burial place for two(?) individuals, possibly monks, of some rank and standing.

### II.1.2.3. Shaft Tomb S.2/07

The rock-hewn mouth of Shaft S.2/07, approx. 1.40 m to the side, was unearthed approx. 0.30 m under the Chapel pavement, close to the foundation edge of the South Wall [cf. *Fig. 4*]. The shaft led to a burial chamber oriented to the west and located approx. 3.70 m under the wall foundation [*Fig. 6*]. The chamber was almost rectangular, approx. 2.80 m (E–W) by 2.40–2.70 m wide, less than 1.60 m in height. A bench of sorts was hewn in the rock by the south wall of the chamber; it was more than

2 m long (E–W), approx. 0.30 m wide and less than 0.30 m high. The chamber may have contained at least two coffins.

The shaft and chamber were both roughly executed, uninscribed and undecorated. An effort seems to have been made, however, to make the walls as smooth as possible. Six big limestone blocks with no decoration were found at the bottom of the shaft.

### II.1.2.4. Shaft Tomb S.3/07

Tomb S.3/07 was located in the southeastern corner of the Chapel, beneath the foundation of the south wall and below tomb S.1/07 (see above) [cf. *Fig. 4*]. The shaft was approx. 1.40 m to the side and almost 3 m (2.78 m) deep. The mouth of the shaft was destroyed when the burial structure S.1/07 was built above it in Late Roman or Coptic times. The undecorated burial chamber, located on the east side, was approximately 2.60 m (E–W) long and 1.20 m wide (narrowing to about one meter at the eastern end), and about 1.20 m high; the deepest point in the chamber was 2.91 m below the Chapel pavement [*Fig. 6*].

Both the shaft and chamber were roughly executed, uninscribed and undecorated. Remains of Third Intermediate Period burials and Coptic material were found. The tomb was disturbed during the Coptic period and again in the 19th(?)–20th century.

## II.2. VESTIBULE AND COURTYARD OF THE CHAPEL OF HATSHEPSUT

### II.2.1. Trial Trench S.05/07

Excavations by the east wall of the Complex were executed in order to examine the building history and present condition of the wall foundation. A trial trench, 3.90 m (N–S) by 2.40 m) was sunk in the section

5 I thank W. Godlewski for consultation and information concerning Coptic tombs.

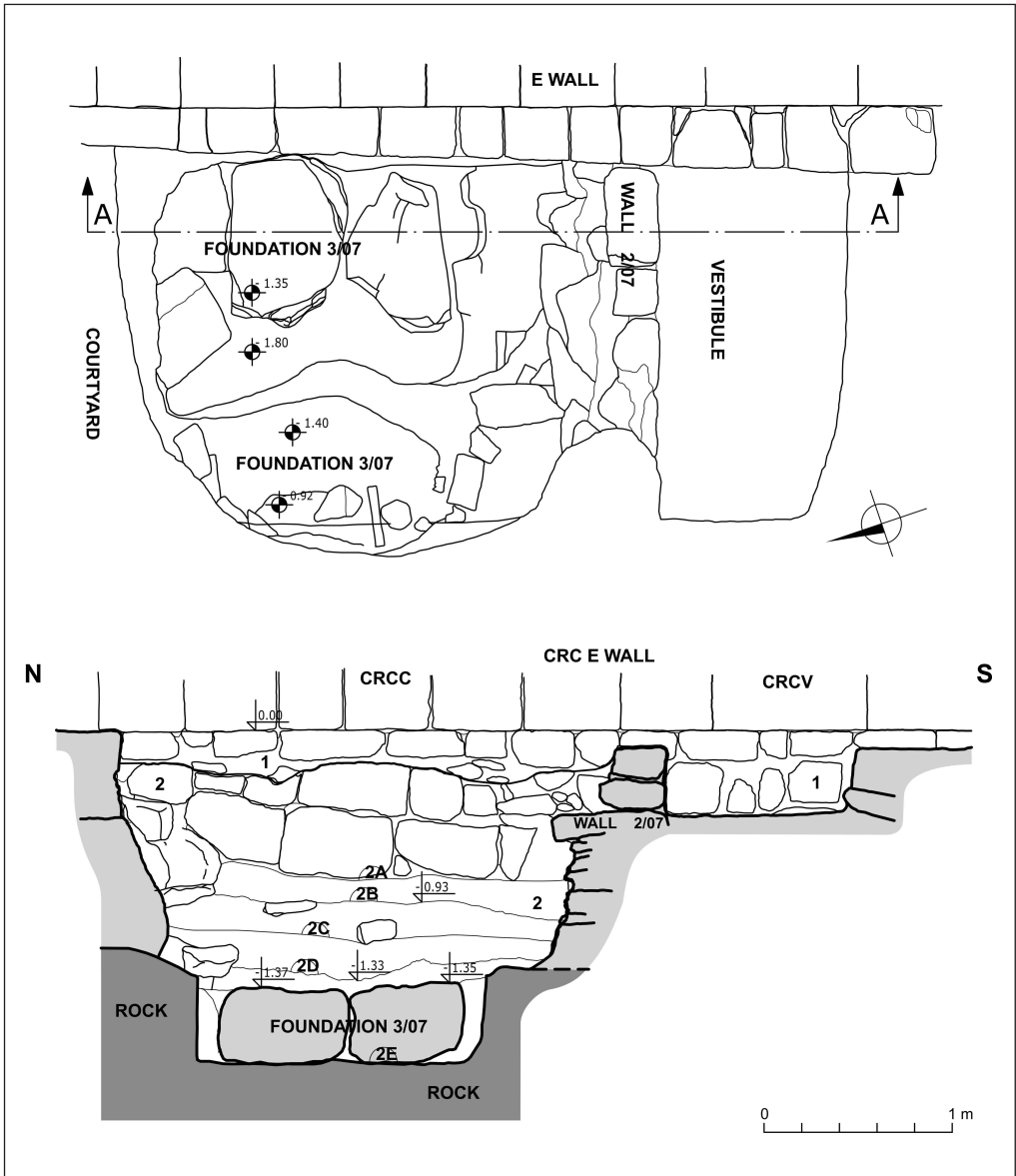

Fig. 7. Structures in trench S.5/07, plan (top) and section N-S (situation 3): foundation 3/07 from the time of the construction of the temple and modern wall 2/07; stratum 1 – recent construction and filling, including wall 2/07 (thin gray cement layer coating the top of the blocks, proof of British restoration activity); stratum 2 – temple construction, including blocks of foundation 3/07; 2A – two layers of limestone blocks bonded in mortar; 2B–2E – four filling layers of “dark green” (2B, 2D) and “black” (2C, 2E) chipped shale (Interpretation Z.E. Szafranski; drawing G. Karpińska and A. Brzozowska)

between the courtyard and vestibule of the Complex, reaching bedrock in the eastern part at about 1.80 m below the pavement and east wall of the chapel.

Two stone structures were uncovered: Wall 2/07 and Foundation 3/07 [Fig. 7, top]. The upper level (Stratum 1) [cf. Fig. 7, bottom] in the trench, including wall 2/07, is evidently the result of British activity in the area of the Temple over a century ago. The wall was reconstructed on an earlier stone foundation from the reign of Hatshepsut (Stratum 2). This has proved of key importance for restoration studies of vestibule height. The blocks of Foundation 3/07 had once supported the northernmost column (or pillar?) of the Vestibule [Fig. 8]. Four filling layers have been identified, consisting of “dark green” (2B and 2D) and “black” (2C and 2E) chipped shale [cf. Fig. 7, bottom], acting as a kind of shock absorption layer for the limestone block foundations (2A), as well as for the east wall of the Complex with its heavy masonry and two big niches at the southern end. The archae-

ological material from this trench was innumerable and mixed, leaving no doubt that the area had been disturbed in the past.

## II.2.2. Courtyard

Following the excavation of trench S.5/07, it is now evident that the lower part of the east wall of the Courtyard was reconstructed by the British Mission (Naville 1908: Pl. cxxiii) and the upper part most probably by Émile Baraize, then Director of Technical Works in the Service des Antiquités. An able restorer and architect, Baraize was not an egyptologist, hence he cannot be faulted for placing several ancient blocks in not their rightful positions. This part of the wall was now dismantled and the blocks subjected to conservation treatment. A new reconstruction project is in preparation by O. Białostocka (in collaboration with A. Brzozowska), who has already attributed several blocks to this wall, including some recently salvaged ones from the fill excavated inside the Chapel of Hatshepsut (see contribution by Olga Białostocka in this volume).

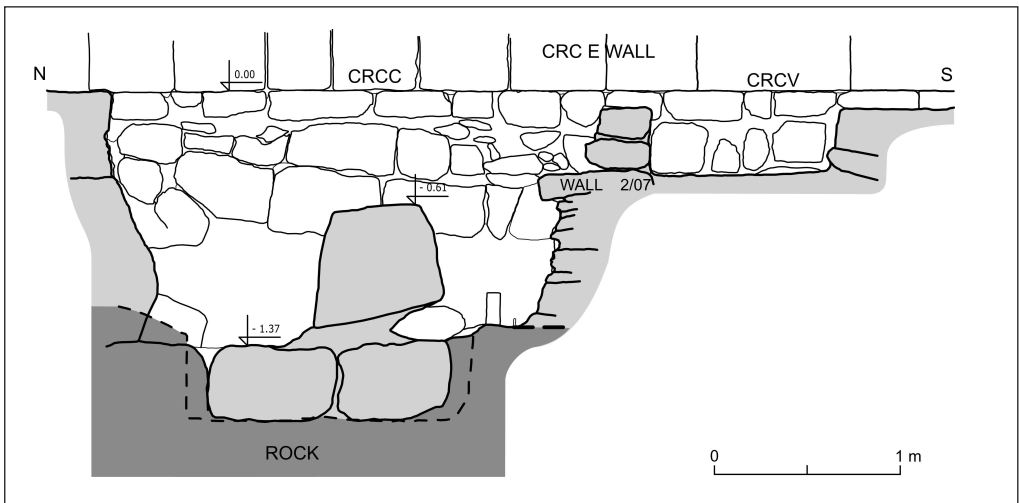

Fig. 8. Trench S.5/07, N-S section (situation 2): foundation 3/07 supporting northernmost column of the Vestibule façade (Drawing G. Karpńska and A. Brzozowska)

### II.2.3. Vestibule

Documentation and restoration study of the south and east walls of the Vestibule focused on the iconographic program and the changes that it underwent in the post-Amarna period. The south wall used to have a surprisingly low cult niche — only about one meter high — but its decorative program remains to be identified. Some of the themes obviously derive from Old and Middle Kingdom temples. Edyta Kopp is in charge of this restoration project (see her report in this volume), while Andrzej Ćwiek is working on Archaic, Old Kingdom and Middle Kingdom references in the Temple of Hatshepsut.

### II.3. THE FINDS

The assemblage is mixed and fragmentary, dating from the Eighteenth Dynasty, the Third Intermediate Period and times of Coptic church activity in the ruins of the Temple. The fill inside the tombs yielded pottery sherds, including Late Roman and Coptic painted wares [*Figs 10 and 11*], fragments of an oil lamp (Field no. 526) and a terracotta figurine of a woman carrying a vase (Field no. 520), mud- and red-bricks, wooden elements of Coptic furniture (Sankiewicz 2009) and of a Third Intermediate Period openwork frieze (Stupko 2009), decorated blocks from the Temple, coffins and cartonnages, shrouds, bandages, numerous faïence beads of different colors and sizes, lapis-lazuli, ushebti (studied by Agnieszka Niemirka), human and animal bones, straw and linen strings, mummy binding tapes and linen, mud stoppers of Coptic amphorae (only in S.1/07) and other artifacts attributable to the

Coptic period, red granite and sandstone. One hieratic ostrakon (Field no. 531) comes from S/07.<sup>6</sup> Artifacts of 20th century date were found in S/07, S.02/07, S.3/07. Fragments of cartonnages and pottery found in S.1/07 match those discovered in S.7A–C/82, S.2/07 and S.3/07. Evidently the material from these trenches must have been mixed in recent years.

Fragments of coffins and cartonnages (more than 800 have been recovered so far)<sup>7</sup> are of excellent artistic quality. They belong to members of Theban royal families of the Twenty-third and Twenty-fifth Dynasties, and the early Twenty-sixth Dynasty (cf. Barwik 2003: Pls 76, 77, 79, 80, 82, 83; Szafrński 2005: 228, Fig. 4, 230; 2007a: 251; 2007b: 116–121; 2009: 278–279, Fig. 8).

The craftsmanship of a cartonnage (Cg.31) of lady Shepenhutaat (about 100 collected fragments) suggests a wealthy customer of the Twenty-third Dynasty from the early 8th century BC.<sup>8</sup> In the central part, the figures of Osiris-Khentimentiu, Hapi and a cobra were molded in fine relief, then painted and varnished in some way [*Fig. 11*, top]. Similarly molded in fine relief were the figures of three lionesses on the bottom of the cartonnage, the outlines of their bodies and features emphasized with a red line [*Fig. 11*, bottom].

New fragments were attached to a previously discovered (Szafrński 2009: 278–279, Fig. 8, left) inner coffin fragment (Cf.31) of a priestly family: God's Father of Amun, Paenmiw, and his parents, God's Father of Amun, PadiAmun, and Mistress of the House, Imiw. The coffin of Paenmiw should be dated to the very late Twenty-fifth

6 E. Kopp is responsible for studying a group of hieratic ostraka found in the temple during recent years.

7 Documented and studied by A. Niemirka, F. Payraudeau, C. May Sheikholeslami and Z.E. Szafrński.

8 Preliminary reconstruction by F. Payraudeau; fragments collected by A. Niemirka and Z.E. Szafrński.

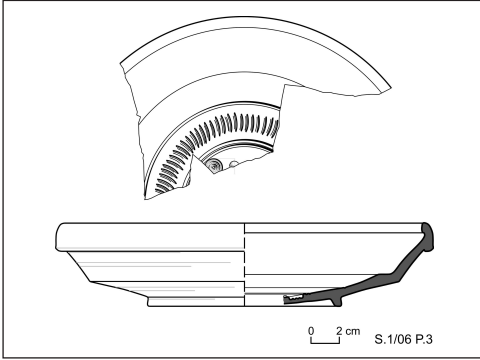

Fig. 9. Late Roman plate  
(Drawing M. Puzzkarski)



Fig. 10. Coptic painted pottery  
(Photo Z.E. Szafranski)



Fig. 11. Fragments of a cartonnage of lady Shepenhutaat (Cg.31) of the Twenty-third Dynasty (early 8th century BC): Figures of Osiris-Khentimentiu, Hapi and a cobra from the middle part (top) and figures of three lionesses in moderately high relief from the bottom of the cartonnage (Photos Z.E. Szafranski)

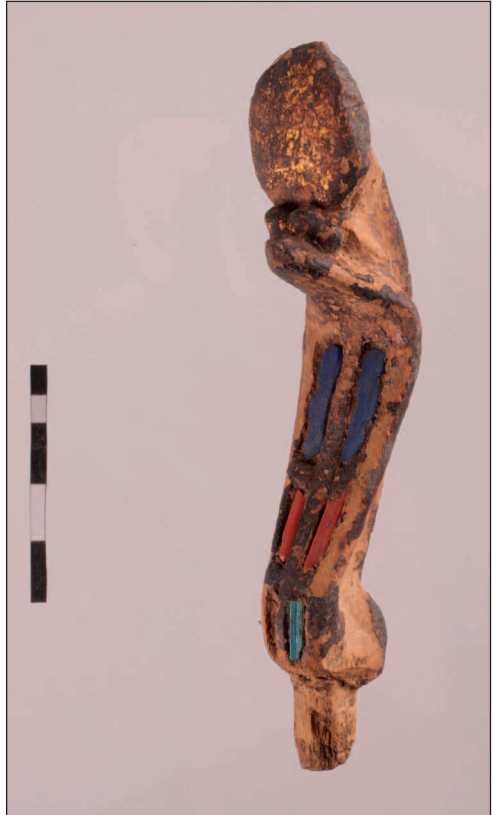

Fig. 12. Gilded cobra figurine, appliqué from the upper part of a bigger composition, Twenty-third Dynasty  
(Photo M. Jawornicki)

Dynasty<sup>9</sup> and is thus one of the latest burials in the Chapel of Hatshepsut, coming from the late 7th century BC, at least two generations later than that of Vizier Padiamonet.

A gilded cobra figurine (H. 12.2 cm) with the body brightened by the addition of inlaid panels filled with semi-precious stones: lapis lazuli, carnelian and blue-green turquoise, comes from the fill of tomb S.2/07 (Szafranski 2007: 124–125) [Fig. 12]. The figurine is an appliqué from the upper part of a bigger composition.

Judging by the available evidence, burials started being made in the ruins of the Temple in the Twenty-third Dynasty, at the very end of the 9th century BC; the temple must have been largely abandoned after a

strong earthquake (c. 900 BC),<sup>10</sup> which destroyed monuments in Thebes, among them the temples in Deir el-Bahari.

Fragments of decorated limestone blocks of different size, originally from the temple walls, were also discovered. Several of these newly discovered fragments could be attributed to the walls of the Chapel of Hatshepsut and to the Complex of the Royal Cult. Some of the small sandstone fragments have turned out to come from the walls of the Temple of Tuthmosis III at Deir el-Bahari.

Two heavily damaged mummies and fragments of human bones were discovered in S.1/07 and S.2/07. One of the mummies (Field no. 573), discovered in S.1/07, comes, most probably, from S.3/07.

### III. MAIN SANCTUARY OF AMUN-RE

Studies of decorated stone, the results of which will be published by Mirosław Barwik, have shown that the Ptolemaic Sanctuary, which forms today the third room of the Main Sanctuary of Amun-Re, was arranged actually after the New Kingdom. The old sanctuary, built by Hatshepsut, was dismantled to give way to a new one built in the Ptolemaic period. In fact, the third room of the Sanctuary appeared to be a niche, decorated with

representations of the queen making offerings to Amun. There are enough remains of the niche facade to allow its reconstruction, with representations of Hatshepsut and Tuthmosis III on both sides of the entrance, and the cartouche of the queen receiving life from Amun placed above the lintel. In the reign of Hatshepsut, the Main Sanctuary consisted of two rooms; there were three big niches in the second room.

### IV. SOUTH CHAMBER OF AMUN-RE

Each of the four walls of the Chamber underwent conservation and thorough restoration. The walls were cleaned and the blocks consolidated. Old decayed putties

were removed and replaced with new ones. Surviving ancient putties were consolidated. All traces left by ancient restorers from the post-Amarna times were also protected (see

9 Leahy 1979. See similar decoration composition of the coffin of Shepenmehyt (Brit. Mus., EA 22814), dated to the Twenty-fifth–Twenty-sixth Dynasty, cf. Taylor 2003: 114, Pl. 64.

10 Geological and seismic investigation, to be published, by A. Avagyan and A. Karakhmyan.

also below, Izabela Uchman-Laskowska's contribution in this volume).

Jadwiga Iwaszczuk's study of the chamber's decoration has resulted in the attribution of a new block to the western jamb (south face) of the entrance to the

Chamber, bearing Hatshepsut's nomen (*s3[t?]* Ra, and the upper part of the cartouche) and the upper part of the cartouche with her prenomen (throne-name). The name had been replaced with the prenomen (T1) of Tuthmosis II.

## V. SCULPTURES OF HATSHEPSUT

More than 1500 pieces of granite sculptures of Hatshepsut discovered by the Metropolitan Museum of Art Expedition (Winlock 1942: 41, Pls 46, 52, 60) and stored in the lapidarium on the Lower Terrace were now registered<sup>11</sup> and are in the process of being studied by Aleksey Shukanau.

Pieces of sandstone sphinxes, also found by the Metropolitan Museum of Art Expedition in 1927–1931 (Winlock 1932), which had been rediscovered in storage at the tomb of Harwa (TT 37) in Asasif at the end of the 2005–2006 season, were moved in March 2007 to the Ali Hassan Storage Museum (so-called “Carter House”) in El-Gurna. A provisional recording of this material was completed in preparation for the conservation, study and restoration of some of the sphinxes [Fig. 13], which will take place at Deir el-Bahari.



Fig. 13. *Rearrangement of one of the sphinxes in storage (Photo A. Smilgin)*

## VI. MIDDLE TERRACE

The tracing documentation (1:1) of the scene in the upper register of the north wall of the North (Birth) Middle Portico, was completed. The scene has been identified as representing the “Going Round the Wall”

rite, known from the Early Dynastic Period and the Old Kingdom (cf. Ćwiek and Sankiewicz 2009). Work also continued on the documentation of building *dipinti* on the south retaining wall of the terrace (for

<sup>11</sup> The documentation was completed by K. Kwiatowski and M. Kujawa, the study has been undertaken by A. Shukanau.



this material, see Wieczorek 2009 and forthcoming reports) and the Hieratic graffiti left on the walls of the Temple. One of the newly recorded graffiti is an inscription scratched on the north wall of the Lower Ramp leading to the Middle Terrace. It was left in the name of Wennefer, “God’s

Father of the Temple of Osiris” and is dated to the regnal year 20 of Ramesses II (to be published by Mirosław Barwik).

As in every season, the static condition and state of preservation of the ceiling in the Sanctuary of the Lower Shrine of Anubis was monitored.

## VII. METROPOLITAN HOUSE

The Metropolitan House in Asasif, today the dig-house of the Polish–Egyptian Mission to the Temple of Hatshepsut, was built almost a century ago for the Metropolitan Museum of Art expedition to Thebes. It was designed by the expedition’s first architect,

William J. Palmer-Jones (1887–1974), who worked with the mission from 1908 until 1913.<sup>12</sup> The House, which was one of the first dig-houses in West Thebes, is a fine example of Egyptian architecture of the early 20th century and it testifies to the “heroic”



Fig. 14. *The Metropolitan House in Asasif, watercolor signed by William J. Palmer-Jones, 1912 (Photo courtesy of the Metropolitan Museum of Art in New York)*

12 I would like to thank Christine Lilyquist for her generous assistance, information and materials concerning both the architect and the Metropolitan House building.

period in the history of excavations and research in the Theban area [*Fig. 14*]. Having become by sheer age a monument of Egypt's cultural heritage, it has come under protection and conservation like the other, more ancient monuments in Thebes.

The Polish Mission, which has occupied the dig-house since 1961 by decision of the then Egyptian Minister of Culture and National Guidance Dr. Tharwat Okasha,

and Director of Egyptian Antiquities Dr. Gamal ed-Din Mokhtar, has aggrandized the structure (a room in the west wing added on in the 1970s) and undertaken more or less extensive renovation works (including major rebuilding of the eastern bathroom in 2004, project documentation by T. Kaczor in the PCMA Archives) required by the condition of the building and its status as a historical monument.

## REFERENCES

Barwik, M.

- 2003 New data concerning the Third Intermediate Period cemetery in the Hatshepsut temple at Deir el-Bahari [in:] N. Strudwick, J.H. Taylor (eds), *The Theban Necropolis: Past, Present and Future*, London: British Museum Press, 122–130

Ćwiek, A., Sankiewicz, M.

- 2009 The Scene of “Going Round the Wall” on the North Wall of the Portico of the Birth, *PAM XVIII [=Reports 2006]*, 290–294

Godlewski, W.

- 2009 MtoM. Early Makuria Research Project. Season 2006, *PAM XVIII [=Reports 2006]*, 463–476

Godlewski, W., Czaja-Szewczak, B.

- 2009 Cemetery C.1. in Naqlun. Tomb C.T.5 and its cartonnages, *PAM XVIII [=Reports 2006]*, 247–260

Grossmann, P.

- 2002 *Christliche Architektur in Ägypten [=HdO 62]*, Leiden–Boston–Köln: Brill

Leahy, A.

- 1979 The name of Osiris written, *SAK 7*, 141–153

Lee, Ch.C.

- 1992 *The grand piano came by camel. Arthur C. Mace, the neglected Egyptologist*, Edinburgh: Mainstream

Naville, E.

- 1896 *The Temple of Deir el-Bahari*, II, London: Egypt Exploration Fund  
 1901 *The Temple of Deir el-Bahari*, IV, London: Egypt Exploration Fund  
 1908 *The Temple of Deir el-Bahari*, V, London: Egypt Exploration Fund

Sankiewicz, M.

- 2008 Worked wood from Coptic Deir el-Bahari. Preliminary remarks, *PAM XVIII [=Reports 2006]*, 300–304

Stupko, A.

- 2008 Third Intermediate Period openwork figures from the Chapel of Hatshepsut in Deir el-Bahari, *PAM XVIII* [=Reports 2006], 295–299

Szafranski, Z.E.

- 2001 Deir el-Bahari. The Temple of Hatshepsut. Season 1999/2000, *PAM XIII* [=Reports 2000], 185–205
- 2005 Deir el-Bahari. The Temple of Hatshepsut. Season 2003/2004, *PAM XVI* [=Reports 2004], 223–235
- 2007a Deir el-Bahari. The Temple of Hatshepsut. Season 2004/2005, *PAM XVII* [=Reports 2005], 241–254
- 2007b Third Intermediate Period and Late Period; Byzantine Period and Islamic Period [in:] *Seventy Years of Polish Archaeology in Egypt. Egyptian Museum in Cairo, Exhibition Catalogue*, Warsaw: PCMA, University of Warsaw, 114–127, 172–173
- 2009 Deir el-Bahari. The Temple of Hatshepsut. Season 2005/2006, *PAM XVIII* [=Reports 2006], 269–284

Taylor, J.H.

- 2003 Theban coffins from the Twenty-second to the Twenty-sixth Dynasty: dating and synthesis of development [in:] N. Strudwick, J.H. Taylor (eds), *The Theban Necropolis: Past, Present and Future*, London: British Museum Press, 95–121

Welsby, D.A.

- 2004 Soba East [in:] D.A. Welsby, J.R. Anderson (eds), *Sudan Ancient Treasures. An Exhibition of Recent Discoveries from the Sudan National Museum*, London: British Museum Press, 227–237

Wieczorek, D.

- 2009 Building *dipinti* from the Temple of Hatshepsut. Preliminary remarks, 2005/2006, *PAM XVIII* [=Reports 2006], 285–289

Winlock, H.E.

- 1932 The Egyptian Expedition 1930-1931, *BMMA* 27, 10–14
- 1942 *Excavations at Deir el-Bahari 1911-1931*, New York

Winlock, H.E., Crum, W.E.

- 1926 *The Monastery of Epiphanius at Thebes*, Part I, New York: Macmillan