

# Edyta Klimaszewska-Drabot

---

## Pottery from the Cemetery in El-Zuma (2007 Season)

---

Polish Archaeology in the Mediterranean 19, 480-487

---

2010

Artykuł został opracowany do udostępnienia w internecie przez Muzeum Historii Polski w ramach prac podejmowanych na rzecz zapewnienia otwartego, powszechnego i trwałego dostępu do polskiego dorobku naukowego i kulturalnego. Artykuł jest umieszczony w kolekcji cyfrowej [bazhum.muzhp.pl](http://bazhum.muzhp.pl), gromadzącej zawartość polskich czasopism humanistycznych i społecznych.

Tekst jest udostępniony do wykorzystania w ramach dozwolonego użytku.

# POTTERY FROM THE CEMETERY IN EL-ZUMA (2007 SEASON)

Edyta Klimaszewska-Drabot

The second season of excavation at the early Makurian cemetery in El-Zuma covered five tumuli (for a report, see above, El-Tayeb in this volume), yielding altogether 77 ceramic vessels which constituted specifically grave goods. Of these 67 have been preserved whole or with only minor damages. Sherds representing 79 other vessels were recorded from the various mounds, shafts and burial chamber fill, as well as from the tunnel breaching the back

of the burial chamber in the largest of the tumuli (T.5). The ceramic material is dated overall to the early Makurian and Christian periods.

The present preliminary report discusses early Makurian vessels from the separate sets of grave goods (for views of pottery vessels *in situ* in the burial chambers of individual tombs and for a sample of the pottery discovered this season, see above, *Figs 6* and *9* on 471 and 475)

## WHEEL-MADE POTS

The collection of wheel-made vessels consists of 43 vessels. The major division is into cups and bowls with a number of subgroups dependent on vessel shape, wall direction, size, type of decoration and technology of production.

### CUPS [*Fig. 1*]

All the cups are characterized by thick, even massive bases. Walls taper towards the rim, which is in itself very thin (0.25–0.40 cm). Both the exterior and the interior surface is red-slipped and burnished in a horizontal direction.

**I.1.** Medium-size cups with flattened, sometimes slightly deformed base, outflared sides, thin rim, slightly turned in. Very

uniform in size: rim diameter 8.9–9.7 cm, height 8.0–8.6 cm.

Seven examples (inv. no. Z25/5, 14, 17, 18, 21, 22, 23), all found in Tumulus 25.

**I.2.** “Tulip-shaped” cups with rounded base, thin outflared rim. Two size subgroups — medium (rim diameter 8.2–12.0 cm, height 8.1–10.6 cm) and large (rim diameter 11.2–13.8 cm, height 10.4–12.0 cm). The medium-sized cups are slender in shape and massive.

Ten examples (inv. no. Z5/4, 5, Z19/3, 6, Z18/4, 2, Z10/11, 12, 15, 20).

**I.3.** Cups similar to type I.2, given a rounded base, sides still outflared but straight in shape. One medium-size example (inv. no. Z10/5) (diameter 12.3 cm, height 10.5 cm).

## BOWLS [Fig. 1]

The 23 bowls making up the second group of wheel-made vessels differ more than the cups in terms of shape variety and surface treatment. Decorated examples have also been recorded.

**II.1.** Deep, heavy, large-sized bowls with slightly conical base, rounded body, rim flat and slightly turned out. Exterior and interior surface red-slipped and burnished horizontally.

Three examples (inv. no. Z10/14, 18, Z19/5), similar in size (diameter 16.5–17.9 cm, height 10.6–12.2 cm).

**II.2.** Small and medium-size hemispherical bowls with flattened, sometimes deformed base, outflared sides, rim plain to flattened and always slightly turned in. Similarly to I.2, the exterior and interior surfaces red-slipped and burnished horizontally.

Thirteen examples (inv. nos Z10/2, 8, 16, 17, 19, Z25/8, 11, 12, 13, 15, 28, 29, 30) ranging between 11.5–13.5 cm in rim diameter and 6.9–8.2 cm in height).

**II.3.** Bowls similar in shape to type II.2, but representing a different technology of production. Wheel marks are more delicate and spaced closer together. Also, the rim is different, always flattened and more turned in.

Four examples (inv. no. Z10/1, 3, 4, 6) varying from 10.3 to 13.6 cm in rim diameter and from 6.7 to 8.5 cm in height. Exterior and interior surface definitely red-slipped. Poor preservation makes it impossible to determine whether the vessels were burnished or polished.

**II.4.** Medium-size bowls, round base, conical shape, sides outflared, plain rim tapered in. Decorated with horizontal grooves under the rim and white painted spots on the rim top, possibly four zones of six dots in each case, but the pattern is partly eroded. Exterior and interior surface red-slipped and polished.

Three examples (inv. nos Z25/19, 25, 27) ranging from 12.0 to 13.5 cm in rim diameter, height almost identical — 8.3–8.4 cm.

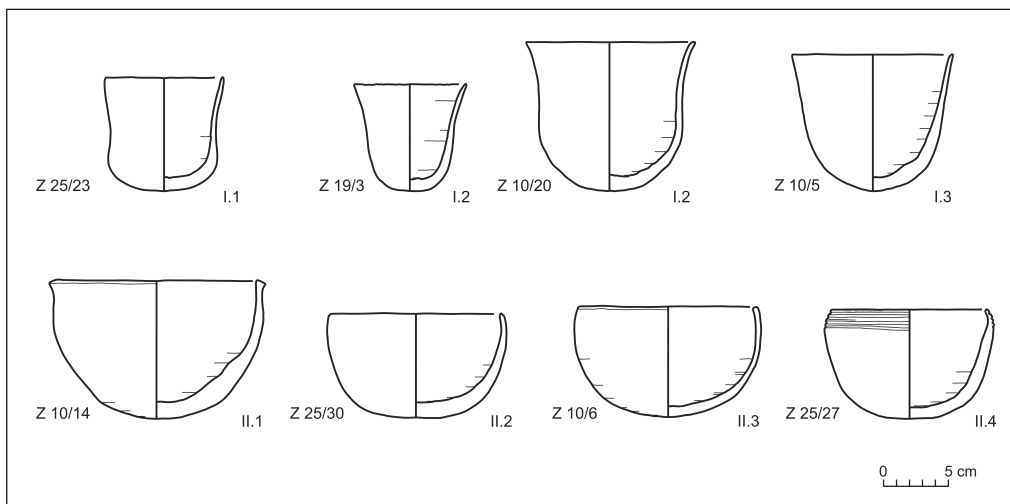

Fig. 1. Wheel-made vessels: cups and bowls  
(All drawings A. Błaszczuk, E. Klimaszewska-Drabot, M. Wybieralska; digitizing E. Klimaszewska-Drabot)

## HANDMADE POTTS

The collection of handmade pots [Figs 2–3] consists of 27 vessels. It was possible to distinguish a number of specific types characteristic of early Makurian burial equipment.

**III.** Spouted bowl (inv. no. Z19/4) with rounded base, rim tapered in. Exterior and interior surface red-slipped and roughly smoothed.

**IV.** Coarse cooking pots with layer of clay added to the base. Interior surface either red-slipped or left roughly smoothed, exterior surface roughly smoothed. Two kinds of these pots exist.

**IV.1.** Open, shallow bowls ranging from 17.4 to 19.7 cm in rim diameter and from 6.6 to 6.9 cm in height. Two examples (inv. nos Z10/13, Z18/3).

**IV.2.** Globular bowls ranging from 14.0 to 17.5 cm in rim diameter and from 11.5 to

14.0 cm in height. Two examples (inv. nos Z10/10, Z18/1).

**V.** Small coarse bowls with layer of clay added to the base and an exterior surface covered with impressed pattern, rather poor quality, soft and poorly fired, very irregular in shape. Also in this case, two varieties of the shape can be distinguished.

**V.1.** Globular bowls (rim diameter 7.5 to 9.5 cm, height 9.0–10.3 cm). Four examples (inv. nos Z25/7, 24, 26, 31).

**V.2.** Hemispherical bowls (rim diameter 11.5–14.0 cm, height 7.1–7.7 cm). Four examples (inv. no. Z25/9, 10, 20, 32).

**VI.** Small globular bowl (inv. no. Z25/16) with layer of clay added to the base, better made and markedly different from vessels of Type IV and V. The bowl was fired in higher temperatures, so the clay is harder. The surface is burnished on the exterior as well as interior

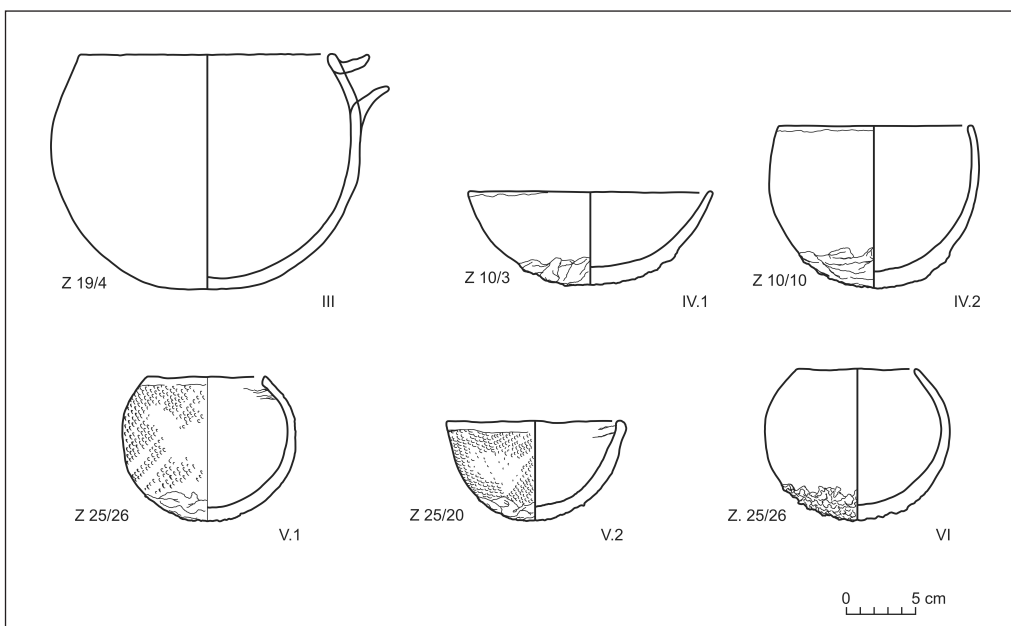

Fig. 2. Handmade vessels: pots and bowls

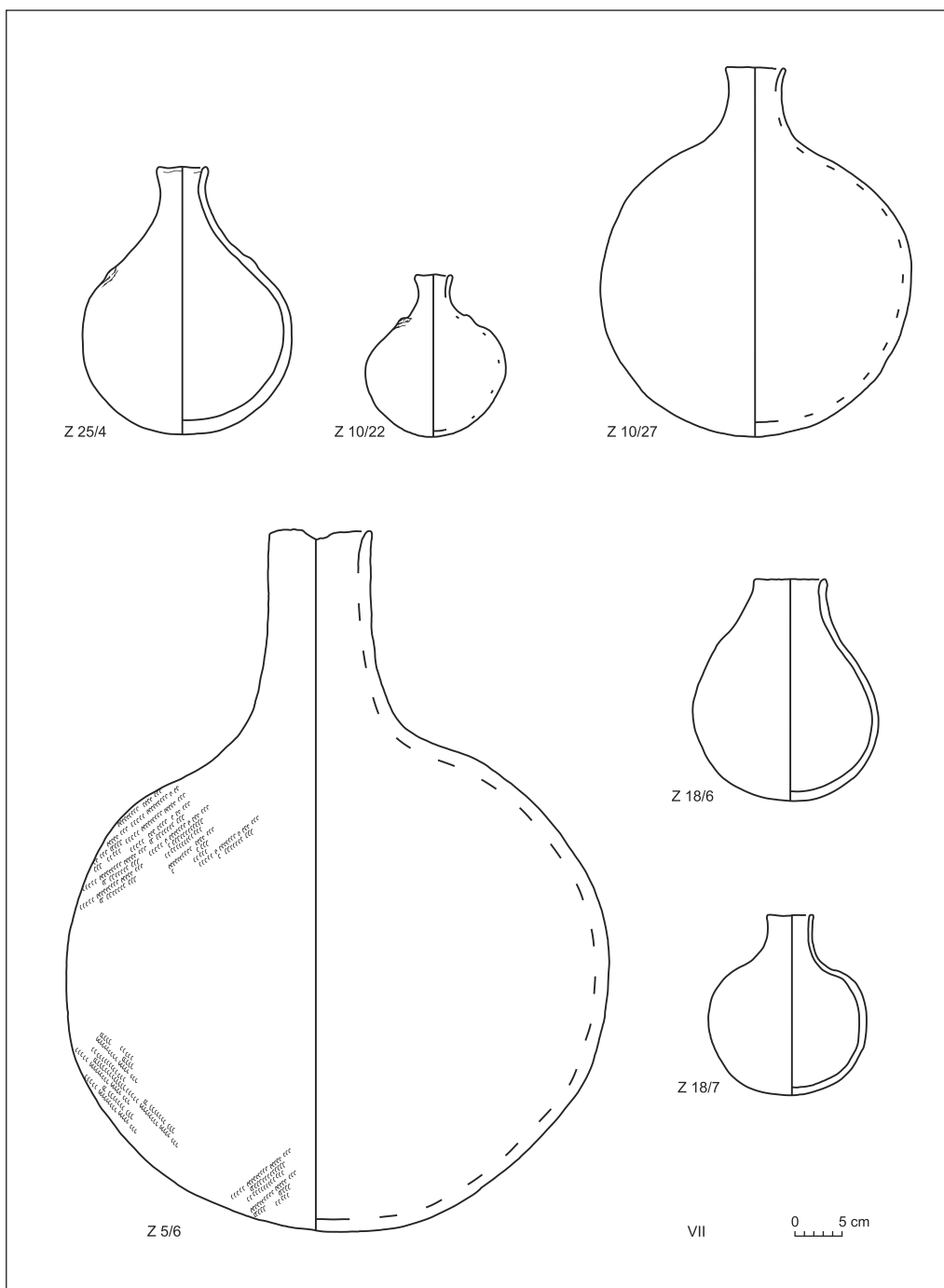

Fig. 3. Handmade vessels: medium-sized bottles and a large beer jar (bottom left)

and the added clay is modeled differently, using a thin-ended tool instead of the usual fingers.

### VII. Bottles — ‘beer jars’

Handmade bottles are extremely common in the Early Makurian pottery repertoire. The 13 vessels discovered in burials excavated this season in El-Zuma exemplify a richness of shapes and sizes. Two bottles (inv. nos Z25/3, 4) from the main burial chamber of Tumulus 25 [Fig 3, see also Fig. 9, top left on 481] represent a form that was characteristic in the southern parts of the Dongola Reach in late Early Makurian times.

They are of medium size (height 28–30 cm), featuring low shoulders and a finely worked external surface which is red-slipped and burnished. The shoulders bear two small bosses on opposite sides of the vessel. Another two bottles (inv. nos Z5/3, Z10/24) may also be assigned to this particular form. A smaller variant of this form is bottle Z10/22 [cf. Fig. 3].

The bottle found in the western chamber of Tumulus 5 (inv. no. Z5/6, Fig. 3) is unusual because of its large size (height 75 cm). An impressed pattern on the body is faint and visible only in a few places. The worn external

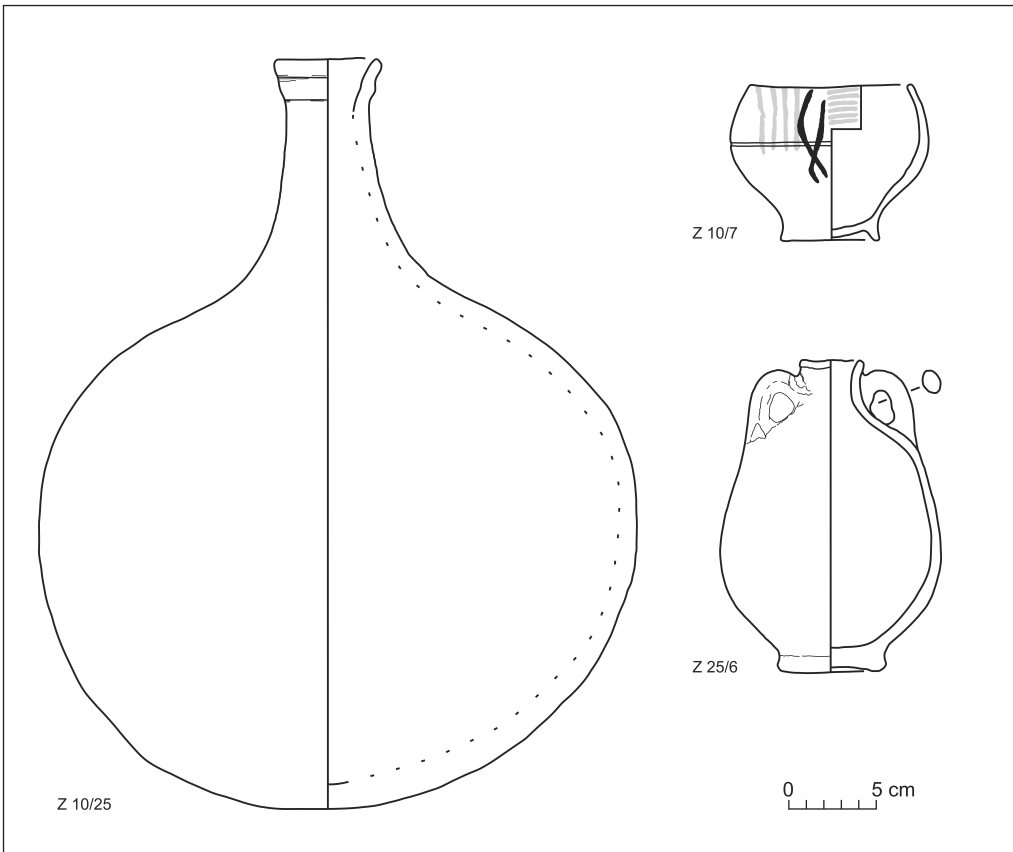

Fig. 4. Imported beer jar and goblet cup (left and top right), local imitation of Egyptian table amphora (Drawing E. Klimaszewska-Drabot)

surface and damaged rim of the vessel testify to its long use before deposition in the burial.

The remaining bottles fall into two sub-categories. One group consists of medium-sized vessels with globular body and

medium-high shoulders, narrow medium-long neck ending in a slightly out-flared or straight rim [cf. *Fig. 3*]. The other group comprises small bottles representing a variety of shapes [cf. *Fig. 3*].

## IMPORTED VESSELS

Imported vessels [*Fig. 4*] — both the finds made this year and the two table amphorae discovered in the previous season at El-Zuma — testify to the status of the individuals buried in these tombs and to the role of trade contacts with Lower Nubia and Egypt.

Of the two wheel-made vessels originating from Lower Nubia discovered in Tumulus 10 the first is a small goblet (inv. no. Z10/7) with footed ring base and tapering sides; it is decorated with one incised line on the mid-body and with, alternately, four groups of long horizontal stripes painted in white and four groups of short notches also painted in white above this line. A dark painted leaf-like motif, much faded, appears additionally on one side. Goblets of this shape are decorated in the same style were very popular in Lower Nubia in the X Group

period and can be dated to the late 4th–early 5th century (Williams 1991: 12).

The other vessel of Lower Nubian origin is a medium-sized wheel-made bottle with globular body, low shoulders, long neck which is broad at the base and narrowing toward the mouth, modelled rim, slightly flattened on top (inv. no. Z10/25).

A small table amphora comes from Tumulus 25 (height 18 cm, inv. no. Z25/6; see also *Fig. 9*, top right on 481). It is made of Nile silt, but it is difficult to establish its origin.

The amphora merits interest also because of its contents. It was filled with small pebbles. Few analogies exist for this kind of filling. One example comes from Kassinger (Paner 1998: 119), another from Usli (Żurawski 2003: 385).

## SUMMARY

Most of the vessels presented here constitute a fairly typical component of burial equipment from the latter part of the Early Makurian period in the southern part of the Dongola Reach and the area just beyond the Fourth Cataract.

Among the wheel-made vessels, those representing I.1, I.2, II.2 and II.4 are extremely characteristic of late Early Makurian graves. Examples of this local tradition are found on many sites, starting

from the north, at Gaddar (El-Tayeb 1994: *Fig. 2*), Hammur (Philips, El-Tayeb 2003: 458–462), Zuma (El-Tayeb 2007: *Fig. 8* and pers. comm.), Tanqasi (Klimaszewska-Drabot 2008: 484–489; 2010: 219–226) and in the Fourth Cataract region from Kassinger Bahri (Kołosowska, El-Tayeb 2007), Gebel Kulgeili (Abdel Rahman, Kabashy 1999: 67–68), Saffi island (Żurawski 2007: Pl. 13) and probably more recently excavated sites there.

Cups of the I.1 category deserve comment as they appear to be typical of the majority of U-shaped graves, like Tumuli 23 and 2 excavated in 2005 in Zuma (personal observation), Tumulus 4 in Hammur (Phillips, El-Tayeb 2003: Pl. 2b), as well as some of the simple graves with vertical shafts and side chamber like graves 1 and 2 at Kassinger Bahri (Kołosowska, El-Tayeb 2007: 39, 44–45). This type of cup often occurs together with bowls of the II.2 and II.4 categories.

A Lower Nubian connection is emphasized by the decoration of II.4. This ornament of engraved horizontal lines originates from the same family as Group X pottery (El-Tayeb 1998: 37) and although these vessels were most certainly produced locally in the Dongola Reach, the painted white dots found on them are clearly patterned on Lower Nubian models.

Bowls of the II.1 group are less frequent. Three vessels were found at Tanqasi (Klimaszewska-Drabot 2008: 488, Fig. 10:1–3). The technology and fabric are not

unlike other wheel-made pots from the region, but the form itself was copied from elsewhere in Sudan. Similar bowls but of much poorer quality have been recorded in the south (Rose 2002: Fig. 6.13, 4105).

Workshop differences observed in the production of bowls of the II.3 group may yet confirm the existence of slightly different technologies being applied to the manufacture of some vessels in the region in question in Early Makurian times.

The bowls with clay added to the base (VI.1 and VI.2) are the most interesting component of the handmade pottery assemblage. They often come in pairs in particular burials (e.g. tumuli 10 and 19) or in threes as in Tumulus 87 in Tanqasi (Klimaszewska-Drabot 2008: 490, Fig. 14) and Tumulus 4 at Hammur (Phillips, El-Tayeb 2003: 459–460).

Note should be taken of small bowls (V.1 and V.2), which, to date, have been found, but without the clay layer added to the base, solely in Gaddar (El-Tayeb 2002: Fig. 28, T2/III, 41, T1/g) and El-Zuma (Tumulus 23, El-Tayeb, pers. comm.).

## REFERENCES

Abdel-Rahman, M.A., Kabashy, H.

1999 Two seasons in the Fourth Cataract region, Preliminary Results, *Sudan & Nubia* 3, 60–70  
El-Tayeb, M.

1994 Excavation at El-Ghaddar–Old Dongola [in:] Ch. Bonnet (ed.), *Études Nubiennes* II, Genève, 65–79

2002 *Genesis of the Makurian Culture in the Light of Archaeological Sources* [=CRIPEL Supplément 6], Villeneuve d'Ascq: Université Charles de Gaulle, Lille III

2003 Excavations at Hammur-Abbassiyah [in:] B. Żurawski (ed.), *Survey and Excavations Between Old Dongola and Ez-Zuma*, [Nubia II, SDRS I] Warsaw: ZAŚ PAN, 130–139

2007 Early Makuria Research Project. Excavations at El-Zuma, preliminary report, *PAM XVI* [=Reports 2005], 389–399

2010 Early Makuria Research Project — excavations at El-Zuma [in:] W. Godlewski, A. Łajtar (eds), *Between the Cataracts, Proceedings of the 11th International Conference for Nubian Studies, Warsaw University, 27 August–2 September 2006, Part Two: Session Papers* [=PAM Supplement Series, 2.2/1-2], Warsaw: PCMA and Warsaw University Press, 205–217



Jacquet-Gordon, H., Bonnet, Ch.

1971–72 Tombs of the Tanqasi Culture at Tabo, *JARCE* 9, 77–83

Klimaszewska-Drabot, E.

2008 Early Makuria Research Project: the pottery, *PAM* XVIII [=Reports 2006], 477–491

2010 Pottery assemblage from the Tanqasi cemetery, Early Makuria Research Project (PCMA) [in:] W. Godlewski, A. Łajtar (eds), *Between the Cataracts, Proceedings of the 11th International Conference for Nubian Studies, Warsaw university, 27 August–2 September 2006, Part Two: Session Papers* [=PAM Supplement Series, 2.2/1-2], Warsaw: PCMA and Warsaw University Press, 219–226

Kołosowska, E., El-Tayeb, M.

2007 Pottery analysis report: sites HP 45 and HP 47, *GAMAR* 5, 37–50

Obluski, A.

2007 Remarks on a survey of the tumuli field at El-Zuma, *PAM* XVI [=Reports 2005], 400–403

Paner, H.

1998 Hamdab Dam Project, preliminary report of the results from work in the Fourth Cataract region 1996–1997, *GAMAR* I, 115–132

Phillips, J., El-Tayeb, M.,

2003 The pottery assemblage from the hammur Abbasiya tumulus field (SDRS Hammur 2) [in:] B Żurwaski, *Survey and Excavations between Old Dongola and Ez-Zuma* [=Nubia II, SDRS I], Warsaw: ZAŚ PAN, 458–462

Rose, P.J.

1998 The Meroitic pottery [in:] D. Edwards, *Gabati. A Meroitic, Post-Meroitic and Medieval Cemetery in Central Sudan* [=Sudan Archaeological Research Society Publication 3], London, 142–177

Shinnie, P.

1954 Excavation at Tanqasi, 1953, *Kush* II, 66–85

Żurawski, B.

2003 *Survey and Excavations between Old Dongola and Ez-Zuma* [=Nubia II, SDRS I], Warsaw: ZAŚ PAN

2007 Where the water is crying. Survey and excavations in Shemkhiya, Dar el-Arab (Sueigi el-Gharb) and Saffi Island carried out by the Polish Expedition to the Fourth Cataract in the winter of 2004/2005. Preliminary report, *Meroitica* 23, 179–205