

Anna Wodzińska

Tell El-Retaba 2008 : The Pottery

Polish Archaeology in the Mediterranean 20, 146-152

2011

Artykuł został opracowany do udostępnienia w internecie przez Muzeum Historii Polski w ramach prac podejmowanych na rzecz zapewnienia otwartego, powszechnego i trwałego dostępu do polskiego dorobku naukowego i kulturalnego. Artykuł jest umieszczony w kolekcji cyfrowej bazhum.muzhp.pl, gromadzącej zawartość polskich czasopism humanistycznych i społecznych.

Tekst jest udostępniony do wykorzystania w ramach dozwolonego użytku.

TELL EL-RETABA 2008: THE POTTERY

Anna Wodzińska

Institute of Archaeology, University of Warsaw

Abstract: The season yielded 30,386 ceramic sherds which were sorted and classified according to a typology prepared based on the surface finds from the first season. The typology was revised and enlarged to include new evidence. Two main phases of site occupation were represented in the assemblage: late New Kingdom and beginning of the Third Intermediate Period. Despite parallels between the two assemblages, the pottery repertoire in one and the other was completely different.

Keywords: Tell el-Retaba, late New Kingdom, Third Intermediate Period, Twenty-first Dynasty, pottery

The second season of work of the Polish–Slovak Archaeological Mission revealed a settlement generally dated to the end of the New Kingdom and beginning of the Third Intermediate Period. 30,386 ceramic sherds were collected during the season. All of them were first sorted into Nile and marl fabrics and secondly into non-diagnostic and diagnostic pieces. Each of the diagnostic sherds (3,783 in total) received a unique number.

The typology of the pottery found in the two excavated areas (Area 1 and 2) was based on the surface finds from the 2007

survey season (Wodzińska forthcoming). This typology was further enlarged and corrected according to new evidence. The ceramics were made mostly of Nile alluvium with only approximately 3% of the material recognized as marl.

The pottery from the 2008 season comes generally from the Twentieth and Twenty-first Dynasty and maybe even the Twenty-second Dynasty. Some of the excavated stratigraphic units appear to be earlier, that is, from the late New Kingdom–beginning of the Twentieth Dynasty.

LATE NEW KINGDOM

Ceramics of this period came from a few stratigraphic units in Area 1. All the late New Kingdom units contained plates with red coated external and internal [*Fig. 1:1*], or only internal surfaces. The vessels have flaring walls and recurved rims. Similar to other pots from Tell el-Retaba, they were made of a Nile B2 sandy variant. They vary

in size, but 20–24 cm in diameter seems to be the most common. Similar bowls dated to the late New Kingdom were also found in Memphis (Aston 2007: 30, *Fig. 20:8, 11, 16–17*).

Small cups of the early Twentieth Dynasty often have red painted rims (similar to *Fig. 2:7*). They are made of

a Nile B2 variant with significant amounts of fine sand. These hemispherical cups range in diameter from 10–13 cm to 16 cm. Similar pots were found at Elephantine (Aston 1999: 34–35, Pl. 6, Fig. 131, late New Kingdom) and Memphis (Aston 2007: 31, Fig. 21:33, 41, 45, 49).

Jars with rounded narrow rims were covered with red slip on the outside and smoothed [Fig. 1:2]. They were made of

Nile B2 sandy clay. Such jars can be dated to the beginning of the Twentieth Dynasty (Aston 1996: 17, 110, Fig. 8b). Some however occur later, during the reign of Ramesses XI (Aston 1999: 33–43, Pl. 9, Fig. 198). The complete vessels have an elongated body measuring approximately 52 cm in height.

A marl jar with a cylindrical neck and rounded rim [Fig. 1:3] came from unit 45.

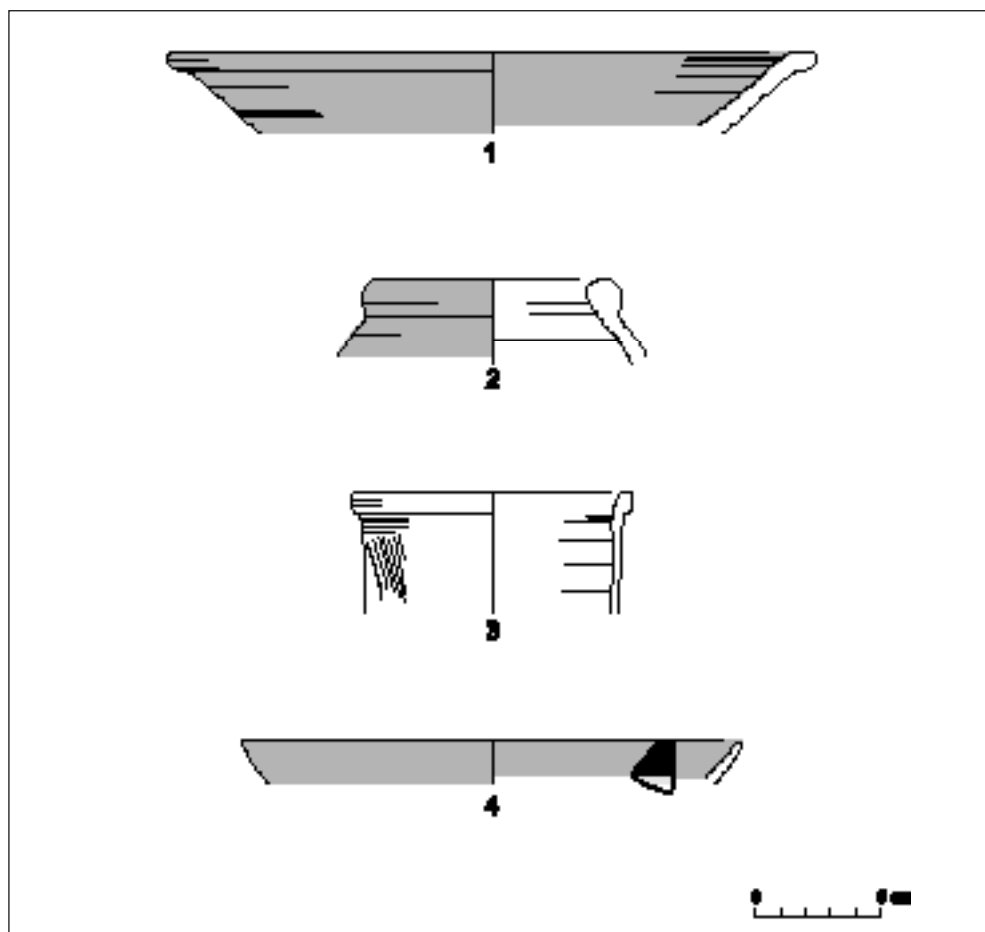

Fig. 1. Pottery from the late New Kingdom

(All drawings K. Górka, S. Gromadzka, A. Wodzińska)

The external surface of the pot was clearly burnished, with shiny vertical stripes. Rims of similar jars made of marl F fabric found at Qantir have been dated to the Ramesside period (Aston 1998: 504–509, Figs 1991–2027).

The date of the late New Kingdom units has been confirmed by the occurrence

of a small fragment of a blue-painted bowl [Fig. 1:4]. According to Aston (1996: 79) the blue-painted decoration does not occur later than the time of Ramesses IV. The bowl is made of Nile B1 clay, covered with red slip and subsequently painted cream and blue inside. The vessel is characterized by its very good manufacturing quality.

THIRD INTERMEDIATE PERIOD

The material from this period [Figs 2–4] is characterized predominantly by the presence of four ceramic vessel types: bowl with flaring walls, small hemispherical cup, flat bread tray, and jar with cylindrical neck and more or less upright rim.

The ceramics that are found most frequently are bowls with flaring walls and recurved rims made of Nile B2 sandy clay [Fig. 2:5]. They represent 23% of all of the diagnostic fragments. They were wheel-thrown and probably made of local material. Their surface was well smoothed without any coat. The vessels vary in size, but the most common are those with 23–26 cm diameter. The bowls (see also Redmount 1989: 363, Fig. 54:27–35) dated to the Third Intermediate Period were also very popular in different regions of Egypt, for instance Elephantine (Aston 1999: e.g. 50–51, Pl. 11, Fig. 257, Twentieth–Twenty-first Dynasty, also 65, 69, Pl. 15, Fig. 494, Twenty-second Dynasty), Memphis (Aston 2007: 34, Fig. 29:153–157) Qantir (Aston 1998: 545, Figs 2220–2222), and Tanis (Bavay 1998: 323–324, Fig. 34:38–39).

The other most common vessel is a small bowl with straight sides also made of Nile B2 sandy clay [Fig. 2:6] (see also Redmount 1989: 361, Fig. 54:1–6). It usually has very

thin walls and its production seems to have been very fast and not very careful. Their size, 10–14 cm in diameter, and clay properties suggest that they were used probably as drinking cups (see also Aston 2007: 33, Fig. 28:137–145). This type of bowl seems to be very well known already in the late New Kingdom when its rim was usually red slipped (see above). Later the decoration gradually disappeared (for uncoated bowls of this type dated to the beginning of the Third Intermediate Period, see e.g. Aston 2007: 33, Fig. 28:142–143, 145), although it is still sporadically visible [Fig. 2:7]. Uncoated bowls were also common in Tanis (Bavay 1998: 321–322, Fig. 33:19–20).

Another frequent find from the site is a flat bread mould [Fig. 2:8] (see also Redmount 1989: 391, Fig. 54:251–255). It is made of Nile C or Nile E clay. Rim diameter varies between 26 and 31 cm. These vessels were very popular across Egypt from the Third Intermediate Period to the Late Period (see, for instance, Aston 1998: 570, Figs 2340–2344; 1999: 200, 203, Figs 1835–1836).

Another characteristic form is a jar with long cylindrical neck and slightly thickened rim [Fig. 2:9] (see, for instance, Aston 2007: 35, Fig. 31:237–244) made of

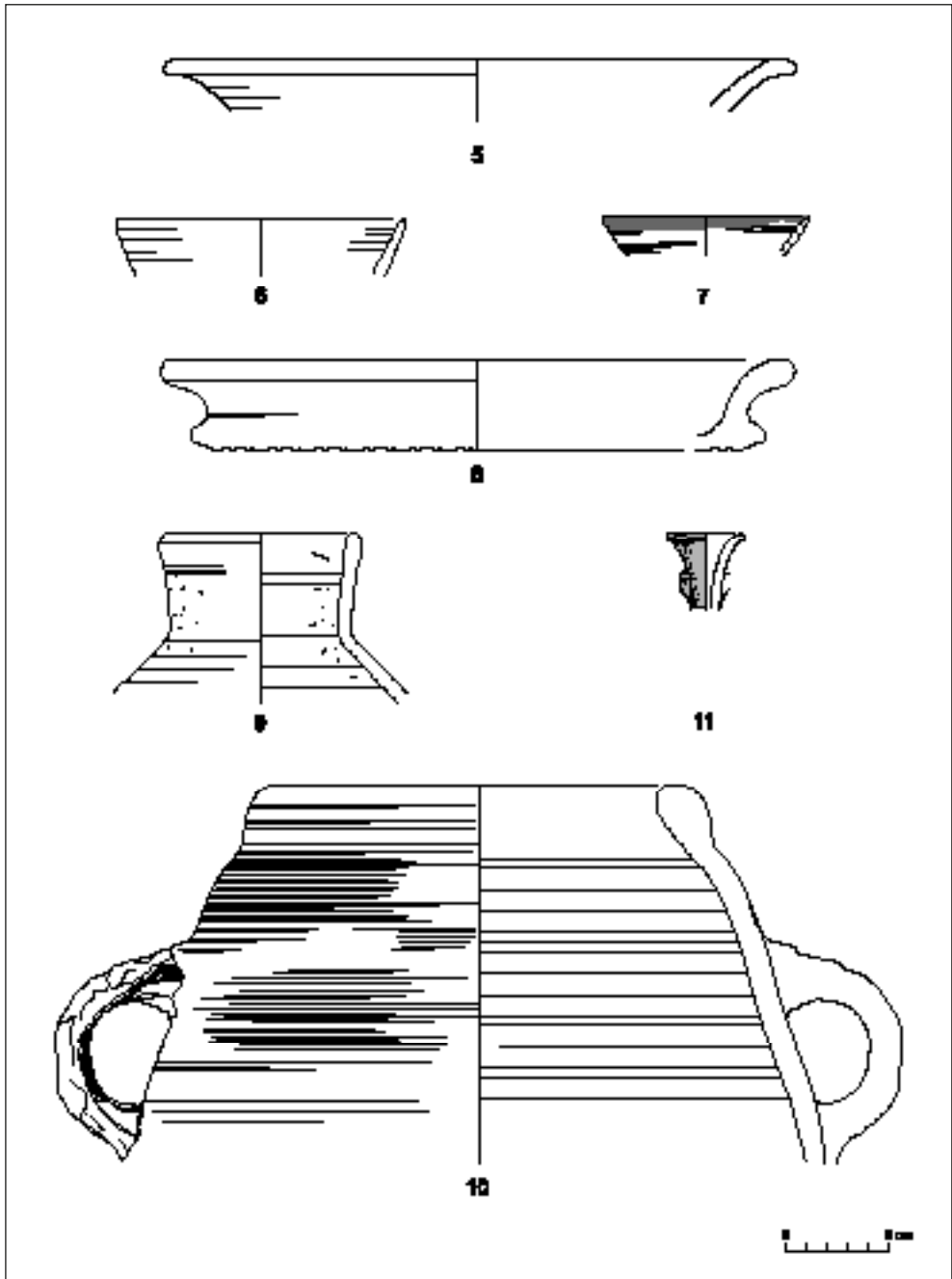

Fig. 2. Pottery from the Third Intermediate Period

Nile B2 sandy clay. The external surface of the jars is very often blackened with traces of soot indicating possible use as a cooking vessel.

Jars with incurved walls and elongated rims, and often with a pair of handles [Fig. 2:10], were also very common (see also Redmount 1989: 395, Fig. 54:270–275). The pots are well known from the Third Intermediate Period contexts at Tell el Daba (Aston 1996: 142, Fig. 40:6, pot K3436, Twentieth–Twenty-first Dynasty) and Mendes (Aston 1996: 130, Fig. 28:8, Ramesside and Third Intermediate Periods).

Fragments of pilgrim flasks were also found. A small two-handled pilgrim flask [Fig. 2:11] is made of Nile B2 clay, with a thin layer of red slip applied to its external surface. The piece is well datable with analogies coming from Twenty-first–Twenty-second Dynasty context at Qantir (Aston 1998: 550–551, Fig. 2243).

The ceramics are plain, except for pilgrim flasks made of Nile B1 clay, and

shallow bowls with ledge rims. No complete pilgrim flask with decoration has been preserved. However, several decorated body

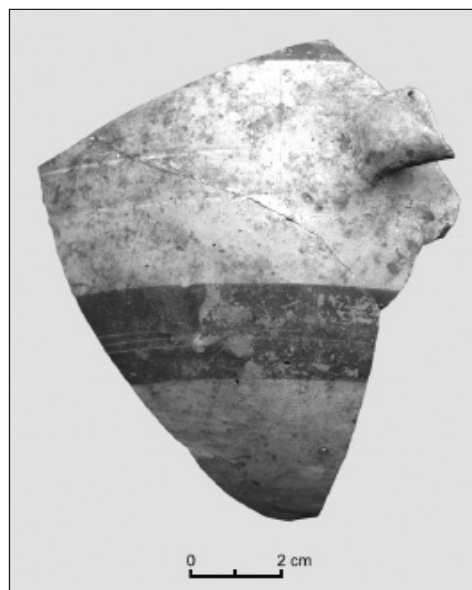

Fig. 3. Painted pilgrim flask from the Third Intermediate Period (Photo A. Wodzińska)

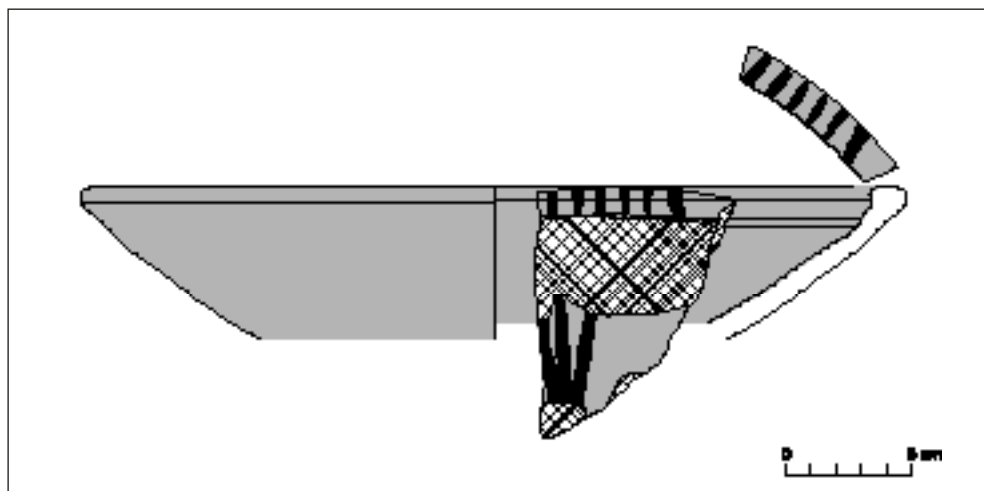

Fig. 4. Painted bowl from the Third Intermediate Period

sherds were discovered. The red-coated pots were painted black on the outside [Fig. 3]. Patterns consisted of simple bands encircling the body. According to Aston based on ceramics from Memphis, such pots can be dated to the 11th–10th century BC (Aston 2007: 53, Fig. 47:557). Similar pots are also known from Tanis (Defernez, Isnard 2000: 170, 211, Pl. XIII, type 17A; Bavay 1998: 321–322, Fig. 33:22).

The bowls were also black-painted [Fig. 4], but the motifs are more elaborate. The interior of the bowl has a stylized floral pattern. Its rim was additionally painted with a pattern of short parallel strokes. Black parallel lines can be found on a bowl from Tanis (Bavay 1998: 319–320, Fig. 32:6). Similar patterns can be seen on pots described by Petrie (Petrie, Duncan 1906: Pl. 36:2).

CONCLUSIONS

The ceramic material coming from the 2008 excavated areas is well defined. The fieldwork revealed two main phases of site occupation, in the late New Kingdom and in the beginning of the Third Intermediate Period. The late New Kingdom, in comparison to the Third Intermediate Period layers, contained less vessels. Both assemblages demonstrate some parallels, e.g. bowls with flaring walls and small hemispherical cups.

Nonetheless, the two assemblages are clearly different. In the course of a relatively short time the pottery repertoire visibly

changed. Jars with round rims slipped with a red coat and marl jars with a cylindrical neck and rounded rim disappeared. Red paint on the rims of small hemispherical cups gradually vanished. The Third Intermediate Period contained neither red-slipped bowls with flaring walls nor blue-painted pots. The decoration of the vessels is also different. Pots from the Twenty-first and Twenty-second Dynasty have black-painted decoration. The motifs are very simple, usually short parallel lines appearing on rims of unrestricted vessels, also circular bands painted on pilgrim flasks.

Dr. Anna Wodzińska
Institute of Archaeology, University of Warsaw
00-927 Warsaw, Poland
ul. Krakowskie Przedmieście 26/28
e-mail: aniawodzinska@yahoo.com

REFERENCES

- Aston, D.A.
1996 *Egyptian Pottery of the Late New Kingdom and Third Intermediate Period (Twelfth–Seventh Centuries BC): Tentative Footsteps in a Forbidding Terrain* [=SAGA 13], Heidelberg: Heidelberger Orientverlag

- 1998 *Die Keramik des Grabungsplatzes Q I. I. Corpus of Fabrics, Wares and Shapes, Forschungen in der Ramses-Stadt. Grabungen des Pelizaeus-Museums Hildesheim in Qantir-Pi-Ramess I*, Mainz am Rhein: Philipp von Zabern
- 1999 *Elephantine XIX: Pottery from the Late New Kingdom to the Early Ptolemaic Period*, [=AV 95], Mainz am Rhein: Philipp von Zabern
- 2007 Pottery of the twelfth to seventh centuries BC [in:] D.G. Jeffreys, D.A. Aston (eds), *The Survey of Memphis III. The Third Intermediate Period Levels*, London: Egypt Exploration Society, 17–59
- Bavay, L.
1998 La céramique dans le secteur du parvis de la porte monumentale [in:] P. Brissaud, C. Zivie-Coche (eds), *Tanis: travaux récents sur le tell Sân el-Hagar: Mission française des fouilles de Tanis*, Paris: Noesis, 316–332
- Defernez, C., Isnard, F.
2000 La céramique provenant de la structure elliptique [in:] P. Brissaud, C. Zivie-Coche, *Tanis. Travaux récentes sur le Tell San el-Hagar II*, Paris: Éditions Noesis, 155–218
- Petrie, W.M.F., Duncan, J.G.
1906 *Hyksos and Israelite Cities*, London: Office of School of Archaeology University College and Bernard Quaritch
- Redmount, C.A.
1989 *On an Egyptian/Asiatic Frontier: an Archaeological History of the Wadi Tumilat*, (PhD dissertation), Chicago: University of Chicago
- Wodzińska, A.
forthcoming Tell er-Retaba: ceramic survey 2007 [in:] P. Kousoulis (ed.), *Proceedings of the 10th International Congress of Egyptologists, Rhodes 22–29 May 2008*, Rhodes: Peeters